

DRAFT

New Zealand Standard

**Draft Number:
DZ 19880.5:2024**

**Public consultation
draft**

**DO NOT USE THIS DRAFT AS A STANDARD –
IT MAY BE ALTERED BEFORE FINAL PUBLICATION**

Standards New Zealand

PO Box 1473, Wellington 6140

Committee representation

This standard was prepared by the P3652 Hydrogen Standards Committee. Membership of the committee was approved by the New Zealand Standards Approval Board and appointed by the New Zealand Standards Executive under the Standards and Accreditation Act 2015.

The committee consisted of representatives of the following nominating organisations:

Coregas
Energy Resources Aotearoa
Fabrum
Fonterra Co-operative Group
Gas Appliance Industry
GasNZ
GNS
Hiringa Energy
HW Richardson Group
HyPotential
Methanex
New Zealand Hydrogen Council
PEC
WorkSafe New Zealand – Energy Safety
Z Energy

Acknowledgement

Standards New Zealand gratefully acknowledges the contribution of time and expertise from all those involved in developing this standard.

Copyright

This document is Crown copyright administered by the New Zealand Standards Executive. You may not reproduce any part of it without prior written permission of the New Zealand Standards Executive, unless your actions are permitted by the Copyright Act 1994.

We will vigorously defend the copyright in this standard. Your unauthorised use may result in a penalty being imposed under the Copyright Act 1994 including fines of up to \$10,000 for every infringing copy (up to a maximum of \$150,000 for the same transaction and for other specified offences) or imprisonment of up to 5 years. If the breach is serious, we may also seek additional damages from you as well as injunctive relief and/or an account of profits.

Published by Standards New Zealand, PO Box 1473, Wellington 6140. Telephone: (03) 943 4259, Website: www.standards.govt.nz.

DZ 19880.5:2024
(ISO 19880-5:2019, IDT)

New Zealand Standard

Gaseous hydrogen – Fuelling stations

Part 5: Dispenser hoses and
hose assemblies

DRAFT

Contents

Preface
[ISO] standard

DRAFT

Preface

The government has a legislated 2050 target of net zero greenhouse gas (GHG) emissions, other than from biogenic methane, and a target under the Paris Agreement to reduce net GHG emissions to 50 per cent below gross 2005 levels by 2030.

Hydrogen is set to play a key role in meeting these targets. (New Zealand has considerable renewable energy resources which could be harnessed to sustainably produce hydrogen for use as a next-generation green fuel source and industrial feedstock.)

To enable the safe integration and novel use of hydrogen in all its forms across New Zealand's energy landscape, a suite of hydrogen-related equipment standards is being adopted.

This standard specifies the requirements for wire- or textile-reinforced hoses and hose assemblies suitable for dispensing hydrogen up to 70 MPa nominal working pressure in the operating temperature range of -40°C to 65°C . It also sets out safety requirements for material, design, manufacture, and testing of gaseous hydrogen hose and hose assemblies for hydrogen fuelling stations.

Hoses and hose assemblies excluded from the scope of this standard are:

- (a) Those used as part of a vehicle high pressure on-board fuel storage system;
- (b) Those used as part of a vehicle low pressure fuel delivery system; and
- (c) Flexible metal hoses.

NOTE –

- (1) This document was developed primarily for hoses and hose assemblies for dispensing high-pressure hydrogen from refuelling dispensers to hydrogen vehicles. Requirements for hoses used to deliver hydrogen from a transportable vessel (for example, a trailer) into a station's buffer storage are addressed in ISO 16964:2019 *Gas cylinders – Flexible hoses assemblies – Specification and testing*.
- (2) Hose assemblies include the hose with connectors on each end (see Figure 1). Each connector has two basic functional elements that are addressed as described below:
 - (a) **Coupling to hose:** This function is defined by requirements and verified (along with the hose itself) by performance-based tests in this document.
 - (b) **Fitting for transition and connection to the piping system or equipment:** This function is addressed by reference to appropriate hydrogen equipment standards and piping codes.

The standard was prepared by the P3652 Hydrogen Standards Committee and is identical to and has been reproduced from ISO 19880-5:2019 *Gaseous hydrogen – Fuelling stations – Part 5: Dispenser hoses and hose assemblies*.

As this standard is reproduced from an international standard, the following applies:

- (d) In the source text, 'this International Standard' should read 'this New Zealand standard';
- (e) A full point substitutes for a comma when referring to a decimal marker.

The terms 'normative' and 'informative' have been used in this standard to define the application of the appendix or annex to which they apply. A 'normative' appendix or annex is an integral part of a standard whereas an 'informative' appendix or annex is for information and guidance.

INTERNATIONAL
STANDARD

ISO
19880-5

First edition
2019-11

**Gaseous hydrogen — Fuelling
stations —**

Part 5:
Dispenser hoses and hose assemblies



Reference number
ISO 19880-5:2019(E)

© ISO 2019



COPYRIGHT PROTECTED DOCUMENT

© ISO 2019

All rights reserved. Unless otherwise specified, or required in the context of its implementation, no part of this publication may be reproduced or utilized otherwise in any form or by any means, electronic or mechanical, including photocopying, or posting on the internet or an intranet, without prior written permission. Permission can be requested from either ISO at the address below or ISO's member body in the country of the requester.

ISO copyright office
CP 401 • Ch. de Blandonnet 8
CH-1214 Vernier, Geneva
Phone: +41 22 749 01 11
Fax: +41 22 749 09 47
Email: copyright@iso.org
Website: www.iso.org

Published in Switzerland

Contents

	Page
Foreword	v
Introduction	vi
1 Scope	1
2 Normative references	2
3 Terms and definitions	3
4 Classification	5
5 Materials and construction	6
5.1 General.....	6
5.2 Lining.....	6
5.3 Reinforcement.....	6
5.4 Cover.....	6
5.5 Static electricity dissipation.....	6
5.5.1 General.....	6
5.5.2 External surface.....	6
5.5.3 Internal surface.....	6
6 Dimensions and tolerances	7
7 Performance requirements and testing	7
7.1 General.....	7
7.2 Leakage test.....	7
7.2.1 General.....	7
7.2.2 Method A.....	7
7.2.3 Method B.....	8
7.3 Hydrostatic strength.....	8
7.3.1 Proof pressure test.....	8
7.3.2 Ultimate strength.....	8
7.4 Electrical conductivity.....	8
7.5 Tensile test of hose assembly.....	9
7.5.1 General.....	9
7.5.2 Test method.....	9
7.6 Vertical load strength.....	9
7.6.1 General.....	9
7.6.2 Test method.....	10
7.7 Torsion strength.....	10
7.7.1 General.....	10
7.7.2 Test method.....	11
7.8 Pressure cycle test (Hydraulic-pressure impulse test).....	12
7.8.1 General.....	12
7.8.2 Apparatus.....	12
7.8.3 Test fluid.....	12
7.8.4 Test temperature.....	12
7.8.5 Test piece.....	12
7.8.6 Procedure.....	13
7.9 Hydrogen impulse test.....	14
7.10 Corrosion test.....	14
7.10.1 General.....	14
7.10.2 Test conditions.....	14
7.11 Minimum bend radius.....	15
7.12 Hose permeation.....	15
7.12.1 General.....	15
7.12.2 Test Method A.....	15
7.12.3 Test Method B.....	16
7.13 Ozone resistance.....	16

7.14	Ultraviolet light and water exposure test.....	16
7.14.1	Applicability and verification.....	16
7.14.2	Test conditions.....	16
7.14.3	Length of exposure.....	16
7.15	Crush test.....	16
7.15.1	General.....	16
7.15.2	Test method.....	17
7.16	Abrasion resistance test.....	17
7.17	Marking material legibility.....	17
7.17.1	General.....	17
7.17.2	Test method.....	17
7.18	Electrical properties of lining material.....	17
7.18.1	General.....	17
7.18.2	Dielectric breakdown voltage.....	17
7.18.3	Volume resistivity.....	17
7.18.4	Criteria of electric properties of lining materials.....	18
8	Marking.....	18
8.1	General.....	18
8.2	Hose assemblies.....	18
8.3	Hose.....	19
8.4	Hose end fittings or couplings.....	19
9	Instruction manual.....	19
9.1	General.....	19
9.2	Selection.....	19
9.3	Installation.....	20
9.4	Inspection and maintenance.....	20
9.5	Safety precautions and usage.....	20
10	Test report.....	20
Annex A (normative) Type tests and routine tests.....		22
Annex B (informative) Production acceptance tests.....		23
Annex C (informative) Hydrogen impulse test.....		24
Bibliography.....		27

Foreword

ISO (the International Organization for Standardization) is a worldwide federation of national standards bodies (ISO member bodies). The work of preparing International Standards is normally carried out through ISO technical committees. Each member body interested in a subject for which a technical committee has been established has the right to be represented on that committee. International organizations, governmental and non-governmental, in liaison with ISO, also take part in the work. ISO collaborates closely with the International Electrotechnical Commission (IEC) on all matters of electrotechnical standardization.

The procedures used to develop this document and those intended for its further maintenance are described in the ISO/IEC Directives, Part 1. In particular, the different approval criteria needed for the different types of ISO documents should be noted. This document was drafted in accordance with the editorial rules of the ISO/IEC Directives, Part 2 (see www.iso.org/directives).

Attention is drawn to the possibility that some of the elements of this document may be the subject of patent rights. ISO shall not be held responsible for identifying any or all such patent rights. Details of any patent rights identified during the development of the document will be in the Introduction and/or on the ISO list of patent declarations received (see www.iso.org/patents).

Any trade name used in this document is information given for the convenience of users and does not constitute an endorsement.

For an explanation of the voluntary nature of standards, the meaning of ISO specific terms and expressions related to conformity assessment, as well as information about ISO's adherence to the World Trade Organization (WTO) principles in the Technical Barriers to Trade (TBT) see www.iso.org/iso/foreword.html.

This document was prepared by ISO/TC 197, *Hydrogen technologies*.

A list of all parts in the ISO 19880 series can be found on the ISO website.

Any feedback or questions on this document should be directed to the user's national standards body. A complete listing of these bodies can be found at www.iso.org/members.html.

Introduction

This document promotes the implementation of performance-based testing for components of dispensing systems and fuelling stations that are based on proven engineering principles, research and the combined expertise of gas utilities, fuel providers, manufacturers, users, and others having specialized experience.

The successful commercialization of hydrogen vehicle technologies requires codes and standards pertaining to fuelling stations, vehicle fuel system components, and the global homologation of standards requirements for technologies with the same end use. Essentially this will allow manufacturers to achieve economies of scale by producing one product for use globally.

International harmonization contributes to reducing technical barriers and stimulates related markets. A series of documents that address hydrogen-fuelled vehicles and fuelling stations is being developed. These documents will provide internationally homologized minimum safety performance criteria at the component level, thus providing a foundation to build a safe “fuelling system”.

This document was developed using the standard ANSI/CSA HGV 4.2-2013.

This document was developed based on five pressure classes of wire or textile reinforced hoses and hose assemblies suitable for use with gaseous hydrogen for hydrogen dispensing. This is based on technologies in use at the time of the development of the requirements.

In the future, other types and classes of hoses and hose assemblies will need to be evaluated to determine the suitability of requirements in this document.

This document applies to newly manufactured hoses and hose assemblies for connecting a dispenser to a high pressure fuelling nozzle.

A nozzle vent hose is included in this document; however the pressure rating may be lower than the nozzle rating, based on the nozzle and dispenser design.

For general hydrogen safety information, see ISO/TR 15916.

Gaseous hydrogen — Fuelling stations —

Part 5: Dispenser hoses and hose assemblies

1 Scope

This document specifies the requirements for wire or textile reinforced hoses and hose assemblies suitable for dispensing hydrogen up to 70 MPa nominal working pressure, in the operating temperature range of -40 °C to 65 °C .

This document contains safety requirements for material, design, manufacture and testing of gaseous hydrogen hose and hose assemblies for hydrogen fuelling stations.

Hoses and hose assemblies excluded from the scope of this document are the following:

- 1) those used as part of a vehicle high pressure on-board fuel storage system,
- 2) those used as part of a vehicle low pressure fuel delivery system, and
- 3) flexible metal hoses.

NOTE 1 This document was developed primarily for hoses and hose assemblies for dispensing high pressure hydrogen from refuelling dispensers to hydrogen vehicles. Requirements for hoses used to deliver hydrogen from a transportable vessel (e.g. trailer) into a buffer storage of a station are addressed in ISO 16964.

NOTE 2 Hose assemblies include the hose with connectors on each end (see [Figure 1](#)). Each connector has two basic functional elements that are addressed as described below:

- 1) Coupling to hose. This function is defined by requirements and verified (along with the hose itself) by performance-based tests in this document.
- 2) Fitting for transition and connection to the piping system or equipment. This function is addressed by reference to appropriate hydrogen equipment standards and piping codes.

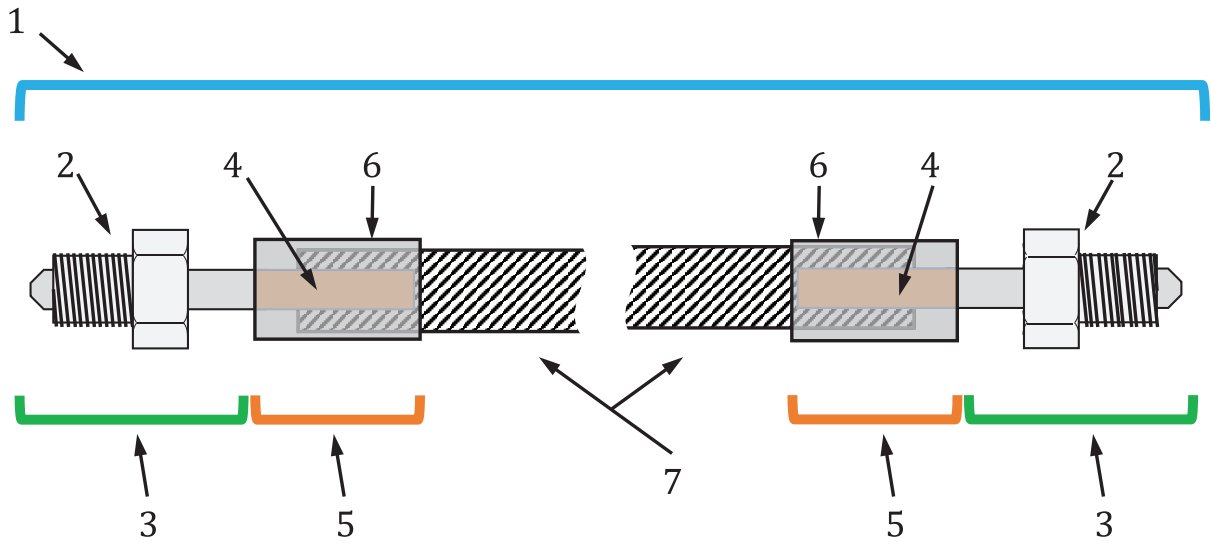

- Key**
- 1 hose assembly
 - 2 mechanical joint
 - 3 fitting
 - 4 nipple
 - 5 coupling
 - 6 crimped socket
 - 7 hose

Figure 1 — Hose assembly and fitting

2 Normative references

The following documents are referred to in the text in such a way that some or all of their content constitutes requirements of this document. For dated references, only the edition cited applies. For undated references, the latest edition of the referenced document (including any amendments) applies.

- ISO 1402, *Rubber and plastics hoses and hose assemblies — Hydrostatic testing*
- ISO 4671, *Rubber and plastics hoses and hose assemblies — Methods of measurement of the dimensions of hoses and the lengths of hose assemblies*
- ISO 4080:2009, *Rubber and plastics hoses and hose assemblies — Determination of permeability to gas*
- ISO 6802, *Rubber or plastics hoses and hose assemblies — Hydraulic impulse test with flexing*
- ISO 6803:2017, *Rubber or plastics hoses and hose assemblies — Hydraulic-pressure impulse test without flexing*
- ISO 7326:2016, *Rubber and plastics hoses — Assessment of ozone resistance under static conditions*
- ISO 8031:2009, *Rubber and plastics hoses and hose assemblies — Determination of electrical resistance and conductivity*
- ISO 8330, *Rubber and plastics hoses and hose assemblies — Vocabulary*
- ISO 8331, *Rubber and plastics hoses and hose assemblies — Guidelines for selection, storage, use and maintenance*
- ISO 9227, *Corrosion tests in artificial atmospheres — Salt spray tests*

ISO 15649, *Petroleum and natural gas industries — Piping*

ISO 16964, *Gas cylinders — Flexible hoses assemblies — Specification and testing*

ISO 17268, *Gaseous hydrogen land vehicle refuelling connection devices*

ISO 19880-1¹⁾, *Gaseous hydrogen — Fuelling stations — Part 1: General requirements*

ISO 30013, *Rubber and plastics hoses — Methods of exposure to laboratory light sources — Determination of changes in colour, appearance and other physical properties*

IEC 60243-1, *Electric strength of insulating materials — Test methods — Part 1: Tests at power frequencies*

IEC 62631-3-1, *Dielectric and resistive properties of solid insulating materials — Part 3-1: Determination of resistive properties (DC methods) — Volume resistance and volume resistivity — General method*

3 Terms and definitions

For the purpose of this document, the terms and definitions given in ISO 8330, ISO 19880-1 and the following apply.

ISO and IEC maintain terminological databases for use in standardization at the following addresses:

- ISO Online browsing platform: available at <https://www.iso.org/obp>
- IEC Electropedia: available at <http://www.electropedia.org/>

3.1

connector

matching parts (such as male and female parts) that can be put together to form a "connection" which permits the transfer of fluids, electric power, or control signals

Note 1 to entry: *Fittings* (3.4) are a type of connector used in piping systems.

Note 2 to entry: Examples of connectors commonly used in hydrogen systems are as follows:

- a) The fuelling nozzle "connector" mates with the receptacle "connector" on the vehicle to form the connection for transfer of compressed hydrogen between the dispenser and the vehicle, as defined in ISO 17268 for this specific application.
- b) The hose assemblies have connectors on each end that allow *coupling* (3.2) to the hoses and connection to the piping system (e.g. hose breakaway device or fuelling nozzle).
- c) Control systems often use electrical connectors to allow rapid and secure assembly or replacement.

3.2

coupling

integrated structure of nipple and socket with end portion of a hose crimped together as shown in [Figure 1](#)

3.3

dispenser hose

fuelling hose

hose assembly (3.5) used for dispensing gaseous hydrogen to vehicles through a nozzle

Note 1 to entry: See [Figure 2](#).

1) Under preparation.

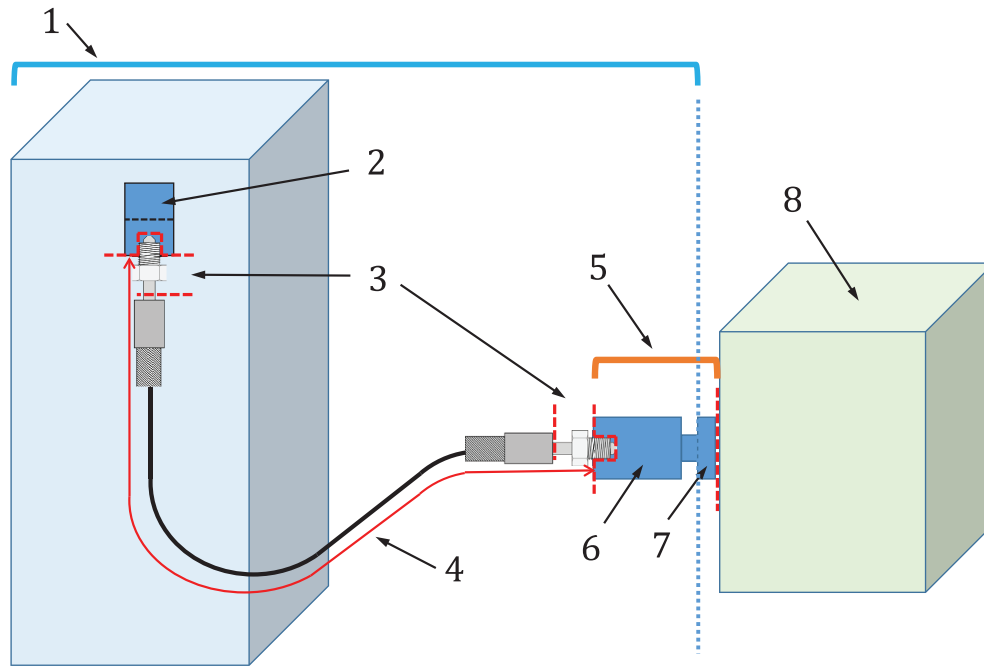

Key

- 1 dispenser
- 2 hose breakaway device (ISO 19880-3)
- 3 fitting (3.4)
- 4 hose assembly (3.5)
- 5 connector (3.1)
- 6 nozzle (ISO 17268)
- 7 receptacle on vehicle (ISO 17268)
- 8 vehicle

Figure 2 — Components connecting a dispenser to a vehicle

3.4 fitting

connector (3.1) used to join any pressure retaining components in the system, and in the case of the hose assembly (3.5), device, usually made of metal, attached to the end of a hose to facilitate connection to equipment or other hose shown in Figure 1

Note 1 to entry: Fittings can be used in a finished hose assembly; however requirements for fittings are out of scope of this document.

3.5 hose assembly

assembly which includes the hose and end connections, including any necessary fittings (3.4), bend restrictors, and appropriate markings

3.6 nozzle vent hose

hose used to depressurize the fuelling nozzle and vent the hydrogen to an approved location

3.7 minimum bend radius

smallest specified radius to which a hose may be bent in service

Note 1 to entry: The minimum bend radius is shown in Table 3.

3.8

pressure rating

maximum pressure at which it is permissible to operate a component as specified by the manufacturer at the maximum temperature expected during service

3.9

proof pressure

pressure applied during a non-destructive test and held for a specified period of time to prove the integrity of the construction

4 Classification

This clause applies to newly manufactured hoses and hose assemblies for dispenser hoses connecting the dispenser to the fuelling nozzle supply port.

Hoses and couplings shall meet the requirements in this document with end fittings selected by the manufacturer, customer, or testing agency as required to connect to the test equipment. Fittings shall be consistent with the requirements of the appropriate documents in the ISO 19880-series, ISO 17268, or ISO 15649.

The end fitting of the hose assembly may be changed to another type that meets requirements defined above without the need to repeat the performance tests for verification of the hose assembly and its coupling as long as the hose coupling remains unchanged.

Some newly manufactured hoses and hose assemblies include vent lines required by some fuelling nozzles. Nozzle vent hose assemblies shall meet the requirements of ISO 16964 or the requirements in this document and be appropriately rated for operation in the vent system that has been defined based on the nozzle manufacturer instructions and the dispenser design.

[Table 1](#) converts Hydrogen Service Levels (HSL), as defined in ISO 19880-1, to pressure levels.

When using ISO 16964, the hose rating is 125 % of the working pressure which is 10 % lower than the pressure ratings in [Table 1](#).

A hose assembly shall be designated according to the pressure classes defined in [Table 1](#) or by the manufacturer's stated pressure rating. The information in [Table 1](#) is taken from ISO 19880-1 (and pressure class H11 is added). The pressure rating of the hose assembly shall be equal to or above the dispenser pressure ratings. For further information regarding the relationships between pressure terms, see ISO 19880-1.

Table 1 — Hose assembly pressure levels and minimum pressure ratings

Pressure level (HSL) (MPa)	Pressure class	Maximum allowable working pressure (MAWP) (Minimum component pressure rating for dispenser components) (MPa)
11	H11	15,13
25	H25	34,38
35	H35	48,13
50	H50	68,75
70	H70	96,25

The hoses and hose assemblies shall be designed to operate at temperatures ranging from $-40\text{ }^{\circ}\text{C}$ to $65\text{ }^{\circ}\text{C}$.

5 Materials and construction

5.1 General

The hose and liner shall be constructed with materials that are resistant to corrosion and exposure to hydrogen.

5.2 Lining

The lining shall be of uniform thickness and free from defects. Defects are defined as but are not limited to bubbles, thinning, gouging, or discoloration.

The lining may also consist of multiple material layers.

5.3 Reinforcement

The reinforcement consists of one or more layers of suitable wire or textile material applied by any suitable technique.

5.4 Cover

The cover shall be resistant to abrasion, cracking, crazing, the effects of exposure to ultraviolet light and ozone, be of uniform thickness, and free from defects. Defects may include but are not limited to bubbles, thinning, gouging, or discoloration. All outer covering shall either be of a permeable material or sufficiently perforated to avoid diffused gas build up.

5.5 Static electricity dissipation

5.5.1 General

Static electricity can be generated on the external and interior surface of a hose assembly.

5.5.2 External surface

The hose assembly shall be constructed so as to provide an external, electrically conductive, bonding path between the end couplings to dissipate external static electric charges.

5.5.3 Internal surface

The hose assembly shall be constructed so that the liner provides an adequate internal layer of prevention to avoid dielectric breakdown by static electricity in the fluid during normal use.

6 Dimensions and tolerances

When measured in accordance with ISO 4671, typical diameters and concentricity of hoses are given in [Table 2](#).

Table 2 — Typical diameters and concentricity of hoses

Nominal size	Inside diameter mm		Maximum outside diameter of hose mm	Concentricity (Maximum variation in wall thickness between inside diameter and outside diameter) mm
	minimum	maximum		
6,3	5,9	7,0	25	0,8
8	7,7	8,5	30	1,0
10	9,3	10,1	35	

7 Performance requirements and testing

7.1 General

Performance requirements shall be determined by the following tests and carried out by type tests, routine tests and production acceptance tests.

Type tests are those required to confirm that a particular hose or hose assembly design, manufactured by a particular method from particular materials, meets all the requirements of this document. The tests shall be repeated whenever a change in the method of manufacture or materials used occurs. They shall be performed on all sizes and types except those of the same size and construction.

Routine tests are those required to be carried out on each length of a finished hose or hose assembly prior to dispatch.

Type tests and routine tests shall be carried out as specified in [Annex A](#).

Production acceptance tests are those required to control the quality of the manufacturing. The frequencies specified in [Annex B](#) are given as a guide only and determined by the manufacturer or between the manufacturer and the customer or the certifying body.

7.2 Leakage test

7.2.1 General

Leakage tests shall be conducted in accordance with Method A for type tests and Method B for routine tests. Method A is also recommended for production acceptance tests.

7.2.2 Method A

When tested in accordance with ISO 4080:2009, Method 3, with the following conditions, the hourly leakage rate shall be less than 20 ml/h under normal pressure and temperature conditions.

The test can be done at room temperature. The amount shall be converted to 15 °C.

The test piece shall have a free length of 0,5 m between the couplings. Connect the test piece to the hydrogen gas supply with a suitable connector and purge the test assembly with hydrogen gas. Adjust the temperature of the water bath to the specified value.

Insert the test assembly into the transparent tube and immerse it in a water bath so that it is inclined at approximately 20° to the horizontal.

Apply the gas pressure of $1,375 \times \text{HSL}$ and maintain it for 10 min. This is the time necessary for releasing trapped air in the reinforcement layer to the outside of the hose through perforated holes. Then, during the next 5 min, collect the gas and measure the amount while maintaining the pressure. This amount is converted to an amount per hour.

7.2.3 Method B

For this test a length of any assembly hose can be used. Hydrogen or helium can be used as test gas. Connect the test piece to the test gas supply with a suitable connector and purge the test assembly with test gas.

Apply the gas pressure of $1,375 \times \text{HSL}$ and maintain it for 10 min for the same reason as noted in [7.2.2](#). Then, still maintaining the pressure, the leakage shall be checked visually for any bubbles from hose body and both coupling ends for 5 min. This check is performed under water by immersing the test piece in a water bath.

Also, a gas leak detector or leak detection fluid may be applied to check leakage in the air.

Leakage can be tested by the permeation test during the first 15 min according to Method A.

The air contained in the reinforcement layer (trapped air), which comes out from perforated holes, can be omitted unless they are abnormal.

7.3 Hydrostatic strength

7.3.1 Proof pressure test

When tested in accordance with ISO 1402, a hose assembly shall withstand a pressure of at least $2,1 \times \text{HSL}$ for 5 min without bursting or visible loss of fluid.

As a test fluid, water or a mixture of water and glycol or oil can be used.

This is a non-destructive test.

7.3.2 Ultimate strength

The hose assembly shall be air oven aged for 70 h at $85 \text{ °C} \pm 1 \text{ °C}$.

Following the oven aging, when tested in accordance with ISO 1402, a hose assembly shall withstand without bursting or visible loss of fluid with a pressure of a minimum of 5 times of HSL for 5 min.

Then, continue to pressurize until the hose assembly bursts and measure the pressure.

As a test fluid, water or a mixture of water and glycol or oil can be used.

This is a destructive test.

7.4 Electrical conductivity

When determined in accordance with ISO 8031:2009, 4.8, the bonding resistance of fuelling hose assembly, from end fitting to end fitting, shall be no greater than 100 k Ω , in order to dissipate static electricity.

This test shall be conducted with the hose un-pressurized.

The bonding resistance of the fuelling hose assembly may need to be no greater than 1 k Ω for manufacturing quality control.

7.5 Tensile test of hose assembly

7.5.1 General

This test is modelling the scenario of the fuelling nozzle being connected to the vehicle while driving away.

This provision applies to a single hose assembly only. For an integrated supply and vent line hose assembly, only the supply portion of the hose assembly shall be tested.

A hose assembly having a free length of 100 mm or longer shall withstand a longitudinal pull force of 3 000 N, as shown [Figure 3](#), without structural damage or leakage after being subjected to accelerated air oven aging. The hose shall comply with [7.3.1](#) and [7.4](#) after the tensile test.

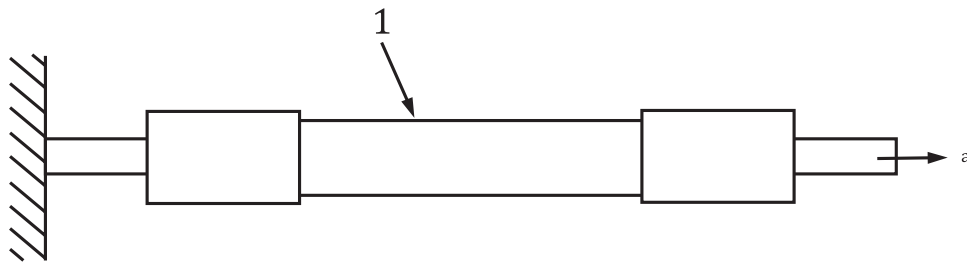

Key

- 1 hose assembly
- ^a Direction of force.

Figure 3 — Tensile test of hose assembly

7.5.2 Test method

The hose assembly shall be air oven aged for 70 h at $85\text{ °C} \pm 1\text{ °C}$.

Following the oven aging, the hose assembly shall be cooled down to a room temperature of $20\text{ °C} \pm 10\text{ °C}$ for at least 2 h prior to the conduct of the tensile test. Then the tensile test shall be conducted at room temperature.

The apparatus outlined in ISO 4671 shall be used for this test.

The hose assembly is then to be placed in a tensile testing machine and connected so that the end couplings and hose are subjected to 3 000 N. With the testing machine adjusted for a rate of travel of 0,2 mm/s or slower, the pull force is to be applied until 3 000 N is attained.

At the completion of this test, hose assemblies shall be subjected to and shall comply with [7.3.1](#) and [7.4](#).

7.6 Vertical load strength

7.6.1 General

This test models the scenario of a person falling against the hose while the fuelling nozzle is connected to the vehicle receptacle or a loop being generated during handling, as shown [Figure 4](#).

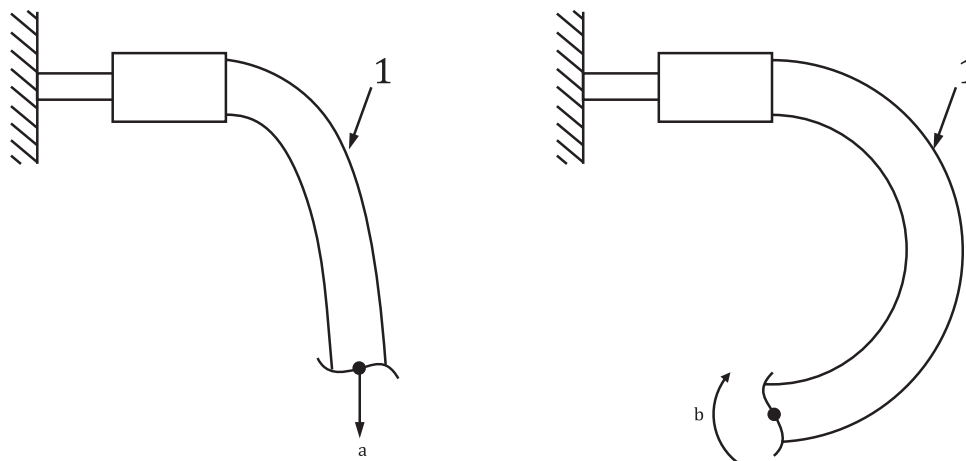

Key

- 1 hose assembly
- a Direction of vertical load.
- b Direction of moment.

Figure 4 — Example of abnormal load

7.6.2 Test method

The test piece shall have a free length of 0,5 m between the couplings. This test shall be conducted at 20 ± 10 °C.

Connect one end of the coupling to the connector fixed horizontally. Apply the vertical load of 340 N to the other free end and maintain the load for 5 min.

After 5 min, remove the load and perform [7.3.1](#) and [7.4](#) for any abnormality.

7.7 Torsion strength

7.7.1 General

This test does not apply to a bonded supply/vent line. When tested in accordance with ISO 6802 with the conditions listed below, a dispenser hose shall withstand 1 000 cycles of horizontally reciprocating movements under atmospheric pressure without damage to the hose or couplings and without leakage in excess of the rate specified in [7.3.1](#) as shown in [Figure 5](#).

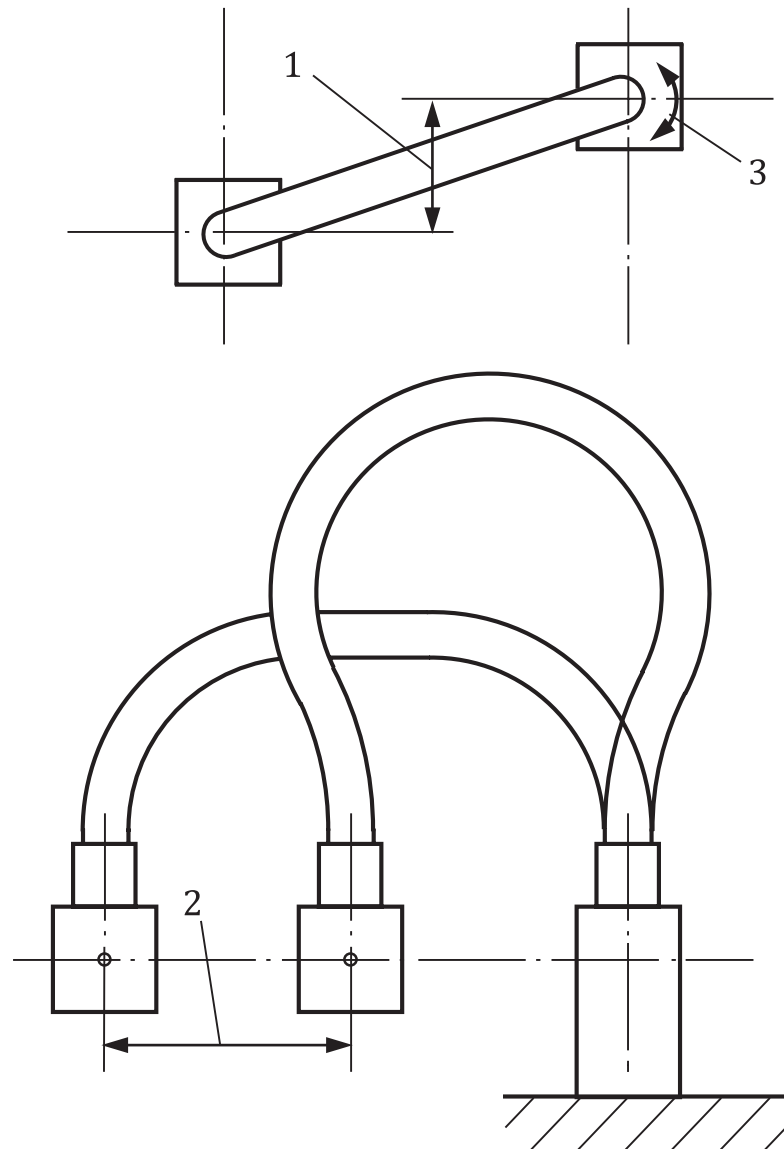
**Key**

- 1 offset
- 2 horizontally reciprocating motion
- 3 direction of torsion

Figure 5 — Torsion strength**7.7.2 Test method**

The test apparatus is a Method 2 horizontally reciprocating manifold.

Offset the sample hose at the distance of four times of outside diameter of hose and mount the test sample at the centre of the stroke making sure there is no twist.

The test shall be conducted under atmospheric pressure and at $-40\text{ }^{\circ}\text{C}$. 1 000 cycles are required.

7.8 Pressure cycle test (Hydraulic-pressure impulse test)

7.8.1 General

This hydraulic test models hot creep conditions at a high temperature.

When tested at impulse pressure equal to $1,25 \times \text{HSL}$, the hose shall withstand a minimum of 100 000 impulse cycles without leakage or failure.

7.8.2 Apparatus

The apparatus for this test shall be in accordance with ISO 6803:2017, Clause 4.

7.8.3 Test fluid

As a fluid for this test, water, mixture of water and glycol or oil (i.e. from grade ISO VG 32 to ISO VG 100 in ISO 3448) can be used. Circulate the fluid at a rate sufficient to maintain a uniform fluid temperature within the test pieces. Other fluids may be used as agreed upon between the customer and the manufacturer.

7.8.4 Test temperature

The test fluid shall be circulated through the test piece at $65 \text{ }^\circ\text{C} \pm 3 \text{ }^\circ\text{C}$.

7.8.5 Test piece

Test pieces shall be complete hose assemblies with suitable end couplings attached. Unless otherwise specified, test four unaged hose assemblies with end couplings which have been attached for not more than 30 days.

Calculate the necessary free length of the hose in the test piece as shown in [Figure 6](#).

For values of d less than 25,4 mm, use $d = 25,4$ mm for the $+2d$ term in the expression for the hose free length, so that the hose between the coupling shell and the start of the bend radius is straight.

The actual free hose length shall agree with the calculated free hose length to within ${}^{+1}_0\%$ or ${}^{+8}_0$ mm, whichever is greater.

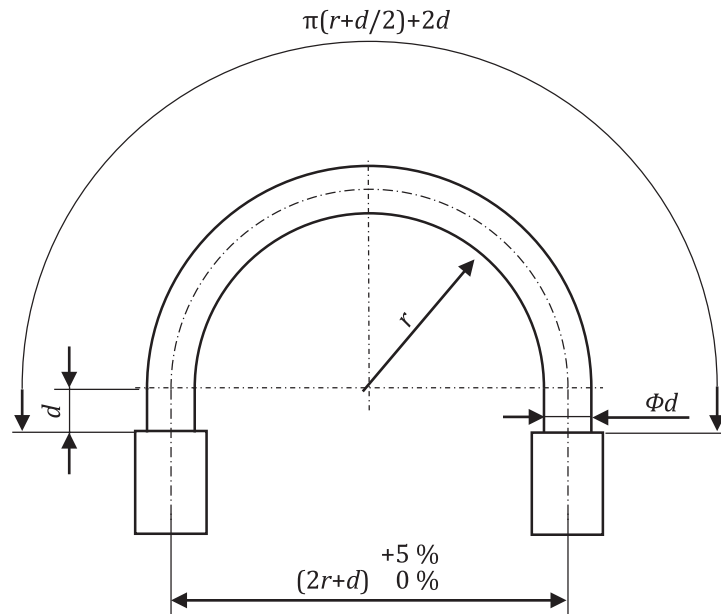
**Key**

- r minimum bend radius
 d hose outside diameter

Figure 6 — Test piece for pressure cycle test

7.8.6 Procedure

Connect the test pieces to the apparatus. The test pieces shall be installed in accordance with [Figure 6](#). Test pieces of hose shall be bent through 180°.

Bring the test fluid to the test temperature and then apply a pulsating pressure equal to 100 % of $1,25 \times \text{HSL}$ internally to the hose assemblies at a uniform rate between 0,1 Hz and 0,4 Hz. Record the pulse rate used. The pressure cycle shall fall within the shaded area of [Figure 7](#).

The pressurization shall be stopped and the impulse test unit shall be allowed to cool down the temperature of the test fluid to room temperature of $30 \text{ °C} \pm 10 \text{ °C}$ at every 30 000 cycles of impulse cycles.

Accelerated cool down procedures, i.e. fans, heat exchangers, etc., may be used to speed up the cooling process.

At every cool down, check test assemblies to ensure they are clean and dry. With fluid heater turned off, resume the test and observe and note leakage for 1 000 impulse cycles.

After cool down, raise the fluid temperature to the specified temperature and restart the impulse cycle until next cool down. Run the test until the hose fails or the number of required cycles is performed.

If a test is stopped before completion of the minimum number of cycles and then restarted, leakage may occur at the hose/coupling junction upon restarting the test and until the test temperature is reached. Leakage less than class 4 as defined in ISO/TR 11340 does not constitute a failure of the hose assembly. Any leakage should be reported in accordance with the classification in ISO/TR 11340.

There shall be no leakage or other malfunction of the test piece before reaching the specified number of cycles.

This test shall be considered a destructive test and the test piece shall be destroyed.

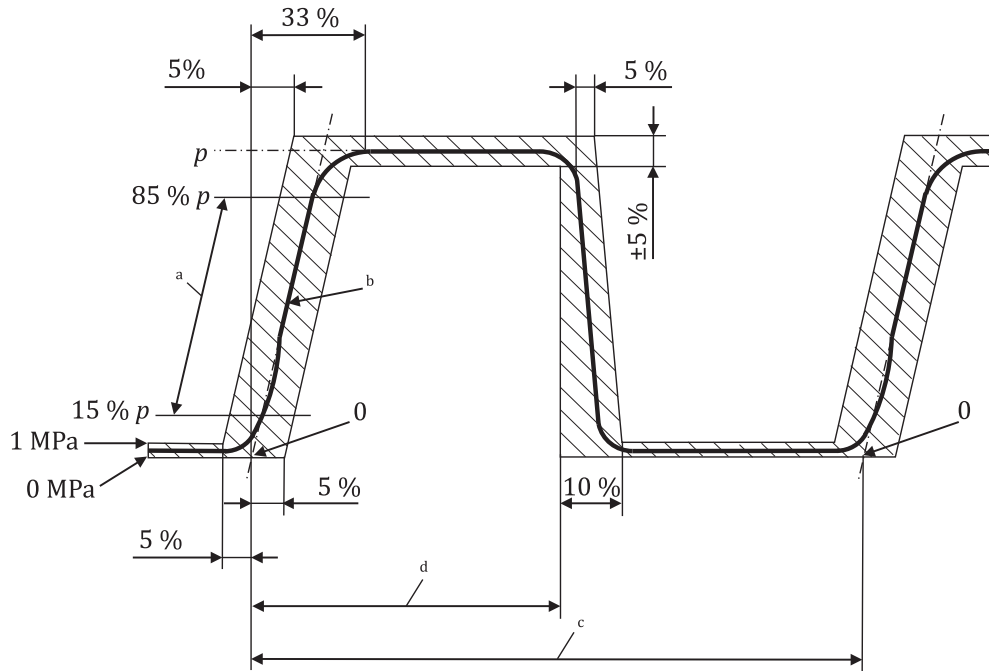

Key

- p test pressure
- a Rate of rise to be determined between these points (50 MPa/s to 100 MPa/s).
- b Secant pressure rise.
- c One pulse cycle (0,1 Hz to 0,4 Hz).
- d 45 % to 55 % of the cycle.

Figure 7 — Pressure pulse wave

7.9 Hydrogen impulse test

This pneumatic test models cold fracture conditions at a low temperature.

Guidance on the hydrogen impulse test is provided in [Annex C](#).

When a hydrogen impulse test is performed, passing criteria require that no blistering shall be observed. Verification as to whether blistering is observed shall be documented.

7.10 Corrosion test

7.10.1 General

When tested in accordance with ISO 9227 with the conditions listed below, couplings and other metal parts shall not show any evidence of corrosion or other deterioration.

Minor corrosion is allowed on areas where there is mechanical deformation of the plating or coating caused by crimping, flaring, bending, and other post-plate metal forming operations.

At the completion of this test, hose assemblies shall be subjected to and shall comply with [7.3.1](#).

7.10.2 Test conditions

Test specimen: Hose assembly.

Test method: Acetic Acid Salt Spray (AASS) or Neutral Salt Spray (NSS).

Temperature: 35 °C ± 2 °C.

Duration of test: 96 h.

This test shall be applied to each nominal diameter, type, and material of hose coupling submitted for examination under this requirement.

7.11 Minimum bend radius

Use a test piece having a length at least four times the minimum bend radius. Measure the hose outside diameter with callipers in the straight-lay position before bending the hose. Bend the hose through 180° to the minimum bend radius (see [Table 3](#) or the manufacturer's literature if the size is different from [Table 3](#)) at 20 °C ± 10 °C and measure the flatness with the callipers. Typical values are shown in [Table 3](#).

When the hose is bent to the minimum bend radius given in [Table 3](#), or the manufacturer's literature if the size is different from [Table 3](#) measured on the inside of the bend, the flatness shall not exceed 10 % of the original outside diameter.

Table 3 — Typical minimum bend radius

Nominal size	Minimum bend radius (mm)				
	H11	H25	H35	H50	H70
6,3	150	150	150	200	200
8	200	200	200	250	250
10	200	200	200	300	300

7.12 Hose permeation

7.12.1 General

The manufacturer may choose either Test Method A or Test Method B.

When tested in accordance with the following test methods, the hourly permeation rate shall be less than 500 ml/m under normal pressure and temperature conditions. After the test, inspect the exterior of the hose for any blistering or swellings. This outside inspection is to verify hose cover perforation.

7.12.2 Test Method A

The hose assembly shall be tested in accordance with ISO 4080:2009, Method 3 with the exceptional conditions listed below.

The test piece shall have a free length of 0,5 m between the couplings. Connect the test piece to the hydrogen gas supply with a suitable connector and purge the test assembly with hydrogen gas.

Adjust the temperature of the water at 23 °C ± 2 °C.

Insert the test assembly into the transparent tube and immerse it in the water bath so that it is inclined at approximately 20° to the horizontal.

Apply the hydrogen gas pressure of 1,25 × HSL and maintain it for 24 h before measuring the permeability to gas. Following preconditioning, while still maintaining the specified pressure, collect the gas for 6 h or record the time to collect between 450 ml and 500 ml of gas.

Repeat the measurement a further two times. Calculate the permeability to gas expressed in millilitres of gas per meter of hose per hour (ml/m/h). From the three measurements, calculate the average the permeability to gas.

7.12.3 Test Method B

Each sample shall have a suitable hose free length excluding end couplings and shall be assembled with applicable couplings. Plug one end of each sample using an approved plug appropriate for the coupling(s) used on the hose being tested and connect the other end to a regulated hydrogen pressure source using appropriate connectors and adapters. Connect the test piece to the hydrogen gas supply with a suitable connector and purge the test assembly with hydrogen gas.

Place the test piece in a chamber equipped with an inert gas inlet and outlet. After purging the chamber with an inert gas, constant flow rate of inert gas is supplied from the inlet. Pressurize the test piece to $1,25 \times \text{HSL}$ using hydrogen and hold the sample at $15 \text{ }^\circ\text{C}$ for 3 h after the pressure is stabilized. Measure the amount of hydrogen gas contained in the inert gas. The period to determine the permeation rate shall be the last 2 h.

7.13 Ozone resistance

When tested in accordance with ISO 7326:2016, Method 1, a hose outer cover shall show no visible signs of cracking or damage under $\times 2$ magnification after 72 h of exposure with an ozone partial pressure of (100 ± 5) parts per hundred million at a temperature of $40 \text{ }^\circ\text{C} \pm 1 \text{ }^\circ\text{C}$. The area immediately adjacent to any tooling shall be ignored. Further details can be found in ISO 7326.

7.14 Ultraviolet light and water exposure test

7.14.1 Applicability and verification

This provision applies to a single hose only. In accordance with ISO 30013, after the exposure test with the conditions listed below, all hose samples shall be visually checked and there shall be no signs of crazing or cracking.

7.14.2 Test conditions

Types of test piece: Type 1 (sample of hose with U-shape bend).

Light source: Fluorescent UV lamps Type 1A (UVA-340), Irradiance 0,76 W at 340 nm.

Exposure cycles: Method A: Artificial weathering.

Dry: 8 h at $60 \text{ }^\circ\text{C}$.

Condensation: 4 h at $50 \text{ }^\circ\text{C}$.

7.14.3 Length of exposure

The test sample shall be cycled continuously under the previously specified cycle pattern for 10 weeks or 1 680 h.

The test sample may be repositioned once per week to obtain uniform exposure to UV radiation, moisture and temperature. Follow the manufacturer's recommendation for rotation.

7.15 Crush test

7.15.1 General

This provision applies to a single hose assembly only. A dispenser hose assembly shall withstand a force of 8 900 N applied externally without incurring structural damage or leakage.

7.15.2 Test method

The length of the sample hose assembly shall be a minimum of 610 mm. The hose shall be placed against a hard, flat, and smooth metallic surface. A force or weight equivalent to 8 900 N shall be uniformly applied for 15 min to the hose, with the force or weight evenly distributed over 150 mm of the hose length in the approximate centre of the sample. The weight shall then be removed, and the hose shall be subjected to and shall comply with [7.2.1](#) and [7.4](#).

If applicable, both hoses of a bonded supply and vent hoses shall be on a horizontal plane when tested. Both hoses shall be in contact with the crushing fixture.

7.16 Abrasion resistance test

When requested by the customer or where regional dispenser designs warrant, dispenser hoses should meet the ISO abrasion resistance test.

7.17 Marking material legibility

7.17.1 General

The legibility of marking materials shall not be adversely affected when marking materials are exposed to heat and moisture as specified in the following test method.

This subclause applies only to markings other than those that are embossed, cast, stamped, or otherwise formed in the part.

7.17.2 Test method

The following tests shall be conducted on two samples. The manufacturer shall have applied the marking materials to the hoses as they would be applied in production.

- a) Marking materials shall exhibit no illegible or defaced printing when rubbed with thumb or finger pressure.
- b) The marking materials shall then be placed in an oven for a period of 2 weeks with the oven temperature maintained at 85 °C as applicable based on the temperature rating.

Following the oven test, the legibility of the samples shall be checked again as specified in a) above. Samples shall then be immersed in water for a period of 24 h, after which the legibility shall be rechecked as specified in a) above.

Good legibility shall be obtained for all samples under the above specified test conditions.

7.18 Electrical properties of lining material

7.18.1 General

This test shall be applied to the hose lining material, unless the electrical properties are not available from the material manufacturers.

7.18.2 Dielectric breakdown voltage

The dielectric breakdown voltage of the lining material shall be determined in accordance with IEC 60243-1.

7.18.3 Volume resistivity

The volume resistivity of the lining material shall be determined in accordance with IEC 62631-3-1.

7.18.4 Criteria of electric properties of lining materials

The acceptability of the allowable dielectric breakdown voltage and volume resistivity of the lining material shall be determined by the following formula:

$$\log(V_B \times t) > \frac{1}{2} \log(R_V) - 6$$

where

V_B is the dielectric breakdown voltage (kV/mm) of the liner material;

T is the thickness of the liner tube of the hose in millimetres;

R_V is the volume resistivity of the liner material.

NOTE If the material is found to be not acceptable, either the conductivity needs to be enhanced by adjustment to the formulation or a different material needs to be selected.

8 Marking

8.1 General

The marking of hose assemblies is a function of the hose and end fitting design and the hose assembly fabrication. In some cases, the hose assembly, including all components within the assembly, may be manufactured by one manufacturer. In other cases, the hose assembly may be manufactured by a different entity to the manufacturer of the individual components. Where the hose assembly manufacturer is not the manufacturer of each component in the hose assembly, the marking of the components within the hose assembly shall meet the requirements of [8.3](#) and [8.4](#).

8.2 Hose assemblies

Hose assemblies shall be marked with at least the following information:

- a) the manufacturer's identification, name, logo, or trademark, e.g. XXX;
- b) the number of this document, i.e. ISO 19880-5;
- c) the pressure classes; (e.g. H70);
- d) Assembly date: the year (last two digits) and then the month of assembly; a slash (/) or a dash (-) can be placed between the year and month.

EXAMPLE XXX/ ISO 19880-5/H70 / 1710.

The maximum working pressure of the assembly is the lowest maximum allowable working pressure of any of its components.

Hose assemblies shall be marked by the following methods:

- a) printing or embossing on the hose;
- b) engraving on the fitting;
- c) stamping on at least one of the couplings;
- d) molding in at least one of the couplings;
- e) a molded rubber name plate cemented in place;
- f) a metal tag or bracket-type marking retained by at least one of the couplings; or

- g) printing on a pressure sensitive label of polyester film.

8.3 Hose

Hoses shall be marked with at least the following information, and the marking shall be repeated every 760 mm or less. The letter height shall be a minimum of 15 % of the hose cover outer circumference.

- a) the manufacturer's name or identification, e.g. YYY;
- b) the number of this document, i.e. ISO 19880-5;
- c) the pressure classes; (e.g. H70);
- d) the nominal size, e.g. 8;
- e) the last two digits of the year and the month of manufacture, e.g. 1710;
- f) the manufacturer's factory identification (MFG internal code); e.g. FAC, if applicable;
- g) the certifying body's name or identification; e.g. NOT, if applicable.

EXAMPLE YYY / ISO 19880-5 / H70 / 8 / 1710 / FAC / NOT.

8.4 Hose end fittings or couplings

Hose end fittings or couplings being permanently marked with the following information is only necessary in the case fittings or couplings are supplied as a single article:

- a) the manufacturer's identification, name, logo, or trademark, e.g. ZZZ;
- b) the number of this document, i.e. ISO 19880-5;
- c) the pressure classes, e.g. H70;
- d) the nominal size, e.g. 8;

EXAMPLE ZZZ/ISO 19880-5/ H70/8

9 Instruction manual

9.1 General

Instructions covering proper selection, installation, inspection, maintenance, safety precautions, and usage shall be provided.

The instructions shall include, as a minimum, statements to the effect that:

- a) The hose assembly complies with this document.
- b) The manufacturer shall provide appropriate installation instructions.
 - 1) Safety precautions.
 - 2) Guidelines for replacement.

9.2 Selection

The hose is suitable only for dispensing of gaseous hydrogen at fuelling stations meeting the requirements of ISO 19880-1.

9.3 Installation

- a) $1,375 \times \text{HSL}$ shall not be exceeded; the user shall provide overpressure protection to prevent operation of the hose at pressures greater than $1,375 \times \text{HSL}$.
- b) The hose assembly shall be of an adequate length for the intended use. Hose assemblies shall not be joined together to achieve the required length.
- c) The hose shall not be used for applications where the bend radius is less than the manufacturer's specified minimum bend radius for the hose.
- d) The hose shall not be stretched, kinked, twisted, or torqued.
- e) The hose assembly shall provide protection for the user from contact damage.
- f) The hose shall not be subjected to temperatures outside the temperature limits.
- g) The hose assembly shall be removed from service and destroyed in the event of mechanical, chemical, or environmental damages.

9.4 Inspection and maintenance

- a) Hose assembly shall be kept in accordance with the conditions specified in ISO 8331 before installation.
- b) The hose assembly shall be inspected in accordance with the manufacturer's instructions. The manufacturer's instructions shall address such items as:

- 1) leakage, in accordance with the applicable installation code;

WARNING — Open flame testing is prohibited. Leak test solutions may contain halides and will require a potable water rinse after testing.

- 2) soft spots, bulges, blisters, kinks, stretching, or discoloration in the hose;
- 3) excessive abrasion exposing the hose reinforcement;
- 4) cuts or cracks in the hose that expose or damage the reinforcement;
- 5) evidence of end connector movement or slippage with respect to the hose;
- 6) electrical conductivity.

9.5 Safety precautions and usage

- a) The hose assembly shall not be stretched, kinked, twisted, or torqued.
- b) Dragging, dropping, contact with sharp objects or edges, and exposure to chemicals shall be avoided.

10 Test report

When requested by the purchaser, the manufacture or supplier shall supply a test report representing the purchased product with each length or batch of hoses containing the following information:

- a) a reference to this document with the year of publication (i.e. ISO 19880-5:2019);
- b) a full description of the hose assemblies tested;
- c) the test items carried out, defined in [Clause 7](#);
- e) the test results;

f) the date of the test.

Annex A (normative)

Type tests and routine tests

[Table A.1](#) gives the tests to be carried out for type testing and routine testing as defined in [Clause 7](#).

Table A.1 — The test items for type test and routine test

Property	Type test			Routine test		
	Hose	Hose assembly	Number of samples	Hose	Hose assembly	Number of samples
Visual examination (inside)	—	—	—	—	—	—
Visual examination (outside)	X	X	minimum 6	X	X	All
Measurement of inside diameter	X	—	minimum 6	X	—	All
Measurement of outside diameter	X	—	minimum 6	X	—	All
Measurement of concentricity	X	—	minimum 6	X	—	All
7.2 Leakage test	—	X	minimum 2	—	X	All
7.3 Hydrostatic strength						
7.3.1 Proof test	—	X	minimum 2	—	X	All
7.3.2 Ultimate strength	—	X	minimum 2	—	—	—
7.4 Electrical conductivity	—	X	minimum 1	—	X	All
7.5 Tensile test of hose assembly	—	X	minimum 2	—	—	—
7.6 Vertical load strength	—	—	minimum 3	—	—	—
7.7 Torsion strength	—	X	minimum 3	—	—	—
7.8 Pressure cycle test (Hydraulic-pressure impulse test)	—	X	minimum 3	—	—	—
7.9 Hydrogen impulse test	—	X	minimum 3	—	—	—
7.10 Corrosion test	—	X	minimum 2	—	—	—
7.11 Minimum bend radius	X	—	minimum 3	—	—	—
7.12 Hose permeation	X	—	minimum 1	—	—	—
7.13 Ozone resistance	X	—	minimum 3	—	—	—
7.14 Ultraviolet light	X	—	4 includes 1 blank	—	—	—
7.15 Crush test	X	—	minimum 2	—	—	—
7.16 Abrasion resistance test	X	—	minimum 3	—	—	—
7.17 Marking material legibility	X	—	minimum 2	—	—	—
7.18 Electrical properties of lining material	X	—	minimum 3	—	—	—

Annex B (informative)

Production acceptance tests

[Table B.1](#) gives the tests to be carried out for production acceptance tests as defined in [Clause 7](#). It is recommended to carry out these tests for every 3 000 m of hose production.

Table B.1 — The test items for production acceptance tests

Property	Production acceptance tests		
	Hose	Hose assembly	Number of samples
Visual examination (inside)	—	—	—
Visual examination (outside)	X	X	minimum 6
Measurement of inside diameter	X	—	minimum 3
Measurement of outside diameter	X	—	minimum 3
Measurement of concentricity	X	—	minimum 3
7.2 Leakage test	—	X	minimum 2
7.3 Hydrostatic strength			
7.3.1 Proof test	—	X	minimum 2
7.3.2 Ultimate strength	—	X	minimum 2
7.4 Electrical conductivity	—	—	—
7.5 Tensile test of hose assembly	—	X	minimum 2
7.6 Vertical load strength	—	—	—
7.7 Torsion strength	—	—	—
7.8 Pressure cycle test (Hydraulic-pressure impulse test)	—	X	minimum 3
7.9 Hydrogen impulse test	—	—	—
7.10 Corrosion test	—	—	—
7.11 Minimum bend radius	X	—	—
7.12 Hose permeation	—	—	—
7.13 Ozone resistance	—	—	—
7.14 Ultraviolet light	—	—	—
7.15 Crush test	—	—	—
7.16 Abrasion resistance test	—	—	—
7.17 Marking material legibility	—	—	—
7.18 Electrical properties of lining material	—	—	—

Annex C (informative)

Hydrogen impulse test

C.1 Test pieces

Test pieces shall be complete hose assemblies with suitable end couplings attached. Test three unaged hose assemblies with end couplings. Calculate the necessary free length of the hose in the test piece as shown in [Figure C.1](#). For values of d less than 25,4 mm, use $d = 25,4$ mm for the $+2d$ term in the expression for the hose free length, so that the hose between the couplings and the start of the bend radius is straight.

The actual free hose length shall agree with the calculated free hose length to within $+1\%$ or $+8_0$ mm, whichever is greater.

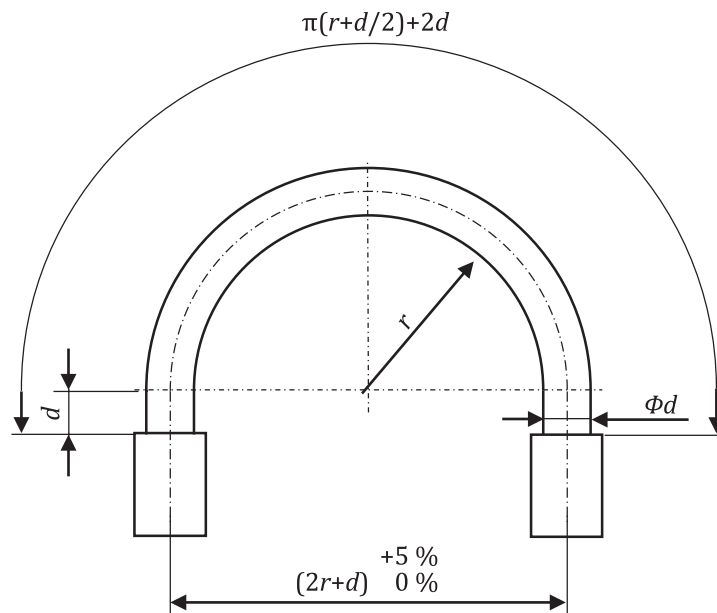

Key

- r minimum bend radius
- d hose outside diameter

Figure C.1 — Test hose assembly for hydrogen impulse test

C.2 Apparatus

C.2.1 Pressure-application apparatus, capable of applying an internal pulsating pressure to the test hose assemblies at a pressurization rate, $(7\% \pm 15\%)$ MPa/s up to $1,25 \times$ HSL using hydrogen gas pressure through the test hose assemblies. Each pressure cycle shall be within the tolerances shown in [Figure C.2](#).

C.2.2 Graphical recorder, digital-storage facility, or oscilloscope, capable of measuring the pressure cycle to ensure that the wave form is within the envelope shown in [Figure C.2](#).

C.2.3 If necessary, **test chamber** capable of controlling the ambient temperature of the test hoses to the same temperature of the test gas with a tolerance of ± 3 °C.

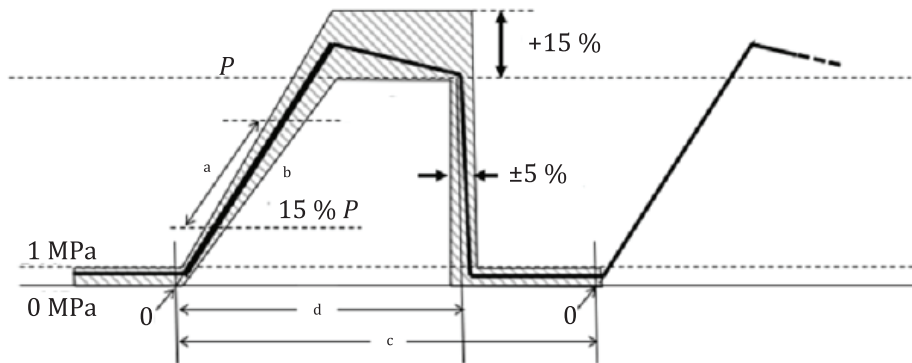

Key

- P test pressure ($1,25 \times \text{HSL}$)
- a Rate of pressure rise to be determined between these points.
- b Secant pressure rise.
- c One pulse cycle (second).
- d Pressurized time, $d/c = 0,66 \pm 20$ %.

The rate of pressure rise to be determined between these points, shall be set to $(7\% \pm 15\%)$ MPa/s.

One pulse cycle (second), shall be $(1,25 \times \text{HSL}/a + 14)$ with a tolerance of ± 15 %.

The actual rate of pressure rise shall be determined as shown in the figure and shall be within a tolerance of ± 15 % of the calculated nominal value.

NOTE The secant pressure rise is the straight line drawn through two points on the pressure rise curve, one point at 15 % of the test pressure and the other at 85 % of the test pressure. Point 0 is the intersection of the secant pressure rise with 0 pressure.

Figure C.2 — Pressure pulse wave form envelope

C.3 Test fluid

Select a hydrogen gas more than 99,9 % in purity as test gas.

C.4 Test procedure

The test gas temperature shall be $-40^{+7,0}$ °C. The ambient temperature shall be controlled to the same temperature as that of gas with a tolerance of ± 3 °C.

It is not required to control the temperature band during a brief decompression stage.

This test should be performed as close as possible to -40 °C, based on T40 condition.

Connect the test hose assemblies to the apparatus. The test hose assemblies shall be installed in accordance with [Figure C.1](#), i.e. test pieces of the hose shall be bent through 180° .

Apply the gas pressure of $1,25 \times \text{HSL}$ and maintain it for more than 12 h before starting applying pulsating gas pressure.

Bring the test gas to the test temperature and then apply pressure cycles, which shall fall within the shaded area of [Figure C.2](#). Continue the test for the required numbers of cycles or until an assembly fails. Required numbers of cycles shall be determined between the manufacturer and the customer depending on the service life of the hose. If no required numbers of cycles are specified, 10 000 cycles

can be used. Record the number of pressure cycles to failure or, if failure did not occur, the number of pressure cycles completed. At the completion of this test, hose assemblies shall be subjected to and shall comply with [7.1](#), [7.2.1](#), and [7.5](#). The test can be interrupted before reaching the target number of cycles and then restarted, as long as the interruption does not affect the test piece or the test conditions. Replacement with tooling for test continuation of other samples is permitted.

This is a destructive test. Hose assemblies which have been subjected to this test should therefore be discarded. The test results obtained are only valid for the combination of hose, coupling type and coupling design that was actually tested.

Bibliography

- [1] ISO 188, *Rubber, vulcanized or thermoplastic — Accelerated ageing and heat resistance tests*
- [2] ISO 3448, *Industrial liquid lubricants — ISO viscosity classification*
- [3] ISO/TR 11340, *Rubber and rubber products — Hydraulic hose assemblies — External leakage classification for hydraulic systems*
- [4] ISO/TR 15916, *Basic considerations for the safety of hydrogen systems*
- [5] ISO 19880-3, *Gaseous hydrogen — Fuelling stations — Part 3: Valves*
- [6] ANSI/CSA HGV 4.2-2013, *Hoses for Compressed Hydrogen Fuel Stations, Dispensers and Vehicle Fuel Systems*

