

**DRAFT**

**New Zealand Standard**

---

**Draft Number:  
DZ 4299**

---

**Public consultation  
draft**

**Committee:  
P4299 Earth Building**

---

DO NOT USE THIS DRAFT AS A STANDARD –  
IT MAY BE ALTERED BEFORE FINAL PUBLICATION

---

Standards New Zealand

---

PO Box 1473, Wellington 6140

---

## Public comment information

### Status

This document is a proposed New Zealand standard under the Standards and Accreditation Act 2015. Issued as a draft in this form, it provides the required statutory opportunity for consideration and comment by the bodies and persons having an interest in the standard.

### How to comment

Closing date for comments **26 May 2024**.

## Committee representation

This standard was prepared by the P4297-99 Earth Buildings Committee. The membership of the committee was approved by the New Zealand Standards Approval Board and appointed by the New Zealand Standards Executive under the Standards and Accreditation Act 2015. The committee consisted of representatives of the following nominating organisations:

|                           |  |
|---------------------------|--|
| Graeme North MNZM (Chair) | New Zealand Institute of Architects              |
| Alan Drayton              | New Zealand Certified Builders Association       |
| Thijs Drupsteen           | Earth Building Association of New Zealand        |
| Min Hall                  | Unitec Institute of Technology                   |
| Verena Maeder             | National Association of Women in Construction NZ |
| Hugh Morris               | Universities New Zealand                         |
| Peter Olorenshaw          | Earth Building Association of New Zealand        |
| Regan Potangaroa          | Universities New Zealand                         |
| Grant Stevens             | Structural Engineering Society New Zealand       |
| Richard Walker            | Engineering New Zealand                          |
| Kerry Walsh               | Building Officials Institute of NZ               |
| Mike Farrell              | Tasman District Council                          |

## Acknowledgement

Standards New Zealand gratefully acknowledges the contribution of time and expertise from all those involved in developing this standard.

## Copyright

This document is Crown copyright administered by the New Zealand Standards Executive. You may not reproduce any part of it without prior written permission of the New Zealand Standards Executive, unless your actions are permitted by the Copyright Act 1994.

We will vigorously defend the copyright in this standard. Your unauthorised use may result in penalties being imposed under the Copyright Act 1994 including fines of up to \$10,000 for every infringing copy (up to a maximum of \$150,000 for the same transaction and for other specified offences) or imprisonment of up to 5 years. If the breach is serious, we may also seek additional damages from you as well as injunctive relief and/or an account of profits.

Published by Standards New Zealand, PO Box 1473, Wellington 6140. Telephone: (03) 943 4259, Website: [www.standards.govt.nz](http://www.standards.govt.nz).

New Zealand Standard

**Earth buildings not  
requiring specific  
engineering design**

## CONTENTS

|                                 |    |
|---------------------------------|----|
| Public comment information..... | 2  |
| Committee representation .....  | 2  |
| Acknowledgement .....           | 2  |
| Copyright .....                 | 2  |
| Referenced documents .....      | 9  |
| Latest revisions .....          | 10 |
| Review of standards .....       | 10 |
| Foreword .....                  | 11 |
| Outcome statement .....         | 12 |

### Section

|       |  |    |
|-------|--|----|
| 1     | SCOPE AND INTERPRETATION .....   | 11 |
| 1.1   | Scope.....   | 11 |
| 1.2   | Limitations.....   | 12 |
| 1.3   | Building components .....  | 16 |
| 1.4   | Interpretation.....  | 17 |
| 1.5   | Definitions .....  | 17 |
| 1.6   | Abbreviations .....  | 23 |
| 2     | GENERAL.....   | 24 |
| 2.1   | Materials .....  | 24 |
| 2.2   | Methods of construction.....   | 25 |
| 2.3   | Wind zones for weather protection.....   | 25 |
| 2.4   | Wind zones for roof design.....  | 26 |
| 2.5   | Snow loads .....   | 26 |
| 2.6   | Durability.....  | 26 |
| 2.7   | Weather protection .....   | 32 |
| 2.8   | Energy efficiency .....  | 42 |
| 2.9   | Internal moisture .....  | 44 |
| 2.9.2 | <i>Accidental overflow</i> .....   | 44 |
| 3     | SITE REQUIREMENTS .....  | 46 |
| 3.1   | Soil-bearing capacity.....   | 46 |
| 3.2   | Soil types .....   | 48 |
| 3.3   | Test method for soil bearing .....   | 48 |
| 3.4   | Bearing.....   | 50 |
|       | The minimum depth of footings below the cleared ground level shall be 200 mm, 150 mm in firm weathered rock, or 100 mm in rock. .... | 50 |
| 3.5   | Site.....  | 50 |
| 4     | BRACING DEMAND .....   | 51 |
| 4.1   | General .....  | 51 |
| 4.2   | Earthquake demand.....   | 51 |
| 4.3   | Calculation of wind bracing demand.....  | 55 |
| 4.4   | Calculation of design bracing demand .....   | 55 |
| 5     | FOOTINGS AND CONCRETE SLAB ON GROUND.....  | 56 |
| 5.1   | General .....  | 56 |
| 5.2   | Footings .....   | 57 |
| 5.3   | Reinforcement of footings.....   | 58 |
| 5.4   | Cover to reinforcement .....   | 66 |
| 5.5   | Vertical wall starter reinforcement .....  | 66 |
| 5.6   | Concrete slab-on-ground floors .....   | 66 |
| 6     | WALLS.....   | 68 |
| 6.1   | General.....   | 68 |
| 6.2   | Wall systems to resist vertical loads.....   | 68 |
| 6.3   | Earth wall systems to resist horizontal loads.....   | 69 |
| 6.4   | Reinforcement of earth walls .....   | 72 |
| 6.5   | Reinforcement of rammed earth walls.....   | 74 |

|       |  |     |
|-------|--|-----|
| 6.6   | Horizontal reinforcement                           | 77  |
| 6.7   | Shear connections                                  | 79  |
| 6.8   | Soffit-to-wall junction                            | 81  |
| 6.9   | Timber-framed gable wall                           | 83  |
| 6.10  | Reverse soffit eaves                               | 83  |
| 7     | STRUCTURAL DIAPHRAGMS                              | 84  |
| 7.1   | General  | 84  |
| 7.2   | Roof and ceiling diaphragms                        | 84  |
| 7.3   | Openings in diaphragms                             | 93  |
| 8     | BOND BEAMS   | 94  |
| 8.1   | General  | 94  |
| 8.2   | Bond beams with structural diaphragms              | 94  |
| 8.3   | Bond beams without structural diaphragms           | 95  |
| 8.4   | Intersection of timber bond beams                  | 99  |
| 8.4.1 | Intersections and joints between timber bond beams | 99  |
| 8.5   | Concrete bond beam details                         | 101 |
| 8.6   | Gable-shaped earth walls                           | 103 |
| 8.7   | Timber gable end walls above earth walls           | 104 |
| 9     | LINTELS  | 105 |
| 9.1   | General  | 105 |
| 9.2   | Timber lintels                                     | 105 |
| 9.3   | Concrete lintels                                   | 110 |
| 10    | WALL OPENINGS AND FIXINGS                          | 117 |
| 10.1  | Windows  | 117 |
| 10.2  | Fixings for timber-framed walls                    | 132 |
| 10.3  | Arches   | 134 |
| 10.4  | Penetrations                                       | 135 |
| 11    | CONTROL JOINTS                                     | 136 |
| 11.1  | General  | 136 |
| 11.2  | Control joints for rammed earth walls              | 138 |
| 11.3  | Control joints for adobe and pressed brick walls   | 139 |
| 12    | EARTH FLOORS                                       | 140 |
| 12.1  | General  | 140 |
| 12.2  | Scope  | 140 |
|       | This section deals with floors that are made from: | 140 |
| 12.3  | Performance criteria                               | 140 |
| 12.4  | Construction details                               | 140 |

## Appendix

|            |  |     |
|------------|--|-----|
| Appendix A | – Basis of engineering design          | 145 |
| Appendix B | – Worked example                       | 151 |
| Appendix C | – There is no Appendix C               | 154 |
| Appendix D | – Light Earth Method or LEM            | 155 |
| Appendix E | – Straw-bale construction              | 174 |
| Appendix F | – INTERNAL ADOBE BRICK VENEER          | 201 |
| Appendix G | – Maintenance schedule for EARTH WALLS | 211 |

## Tables

|           |  |    |
|-----------|--|----|
| Table 2.1 | – Screw sizes  | 25 |
| Table 2.2 | – Wind speed zone designations   | 25 |
| Table 2.3 | – Maximum erodibility index for earth walls  | 34 |
| Table 4.1 | – Earthquake zones   | 52 |
| Table 4.2 | – Site earthquake factor   | 55 |
| Table 6.1 | – Bracing capacity of reinforced earth walls – Heavy earth (1400–2200 kg/m <sup>3</sup> )                            | 72 |
| Table 6.2 | – Spacing of vertical reinforcement in earth walls in earthquake zone 1  | 73 |
| Table 6.3 | – Spacing of vertical reinforcement in earth walls in earthquake zone 2  | 73 |
| Table 6.4 | – Spacing of vertical reinforcement in earth walls in earthquake zone 3  | 73 |
| Table 6.5 | – Spacing of vertical HD12 reinforcement in rammed earth walls without horizontal reinforcement in earthquake zone 1 | 77 |

|  |            |
|--|------------|
| Table 6.6 – Spacing of vertical HD12 reinforcement in rammed earth walls without horizontal reinforcement in earthquake zone 2 .....     | 77         |
| Table 6.7 – Spacing of vertical HD12 reinforcement in rammed earth walls without horizontal reinforcement in earthquake zone 3 .....     | 77         |
| Table 6.8 – Spacing of shear connectors at base of earth walls .....   | 80         |
| Table 6.9 – Spacing of shear connectors at top of earth walls .....  | 80         |
| Table 8.5 Concrete bond beam for wind .....  | 99         |
| <b>Table 10.1 – Shrinkage allowance for a 2 m height opening. Different heights may be extrapolated and interpolated from this .....</b> | <b>133</b> |
| Table A.1 – Design strengths (MPa) for standard grade earth wall construction .....  | 146        |
| Table A.2 – Strength reduction factors .....   | 146        |
| Table A.3 – Basic load data .....  | 146        |
| Table A.4 – Site earthquake factor .....   | 147        |

## Figures

|  |            |
|--|------------|
| Figure 2.1 – Durability design .....   | 27         |
| <b>Figure 2.2 – Exposure zone map (North Island) .....</b>                             | <b>30</b>  |
| Figure 2.3 – Exposure zone map (South Island) .....                                    | 31         |
| Figure 2.4 – Definition of roof overhang height and roof overhang width .....          | 35         |
| Figure 2.5 - Minimum roof overhang width for low wind zone .....                       | 36         |
| Figure 2.9 – Protection for sheltered walls – plan .....                               | 41         |
| Figure 2.10 – Thermal conductivity values for earth walls .....                        | 42         |
| Figure 3.1 – Relationship of foundation to nearby sloping ground surface .....         | 47         |
| Figure 4.1 – Earthquake zones (North Island) (see 4.2.2) .....                         | 53         |
| Figure 4.2 – Earthquake zones (South and Stewart Islands) (see 4.2.2) .....            | 54         |
| <b>Figure 5.1 – Foundation details at footing step .....</b>                           | <b>56</b>  |
| Figure 5.2 – Footing height clearances .....   | 58         |
| Figure 5.3 – Footing reinforcement in earthquake zone 1 .....                          | 59         |
| Figure 5.5 – Reinforcement at footing or bond beam intersections .....                 | 60         |
| Figure 5.6 – Footings –general details including shear key options .....               | 61         |
| <b>Figure 5.7 – Footing – Insulated concrete floor .....</b>                           | <b>62</b>  |
| Figure 5.8 – Footing – Insulated slab and footing .....                                | 63         |
| Figure 5.9 – Footing – Insulated slab with brick facing .....                          | 63         |
| <b>Figure 5.10 – Footing – Insulated earth floor on slab .....</b>                     | <b>64</b>  |
| Figure 5.11 – Footing – Earth floor .....  | 65         |
| <b>Figure 6.1 – Bracing line support system and openings at external corners .....</b> | <b>70</b>  |
| Figure 6.2 – Determining average wall height .....                                     | 72         |
| Figure 6.3 – Reinforcing and shear connectors for reinforced earth walls .....         | 76         |
| Figure 6.4 – Horizontal reinforcement cut from steel mesh .....                        | 78         |
| <b>Figure 6.5 – Horizontal reinforcement for earth walls .....</b>                     | <b>79</b>  |
| <b>Figure 6.6 – Soffit-to-wall junction .....</b>                                      | <b>82</b>  |
| Figure 6.7 – Sloping soffit-to-wall junction .....                                     | 82         |
| Figure 6.8 – Timber-framed gable to end wall .....                                     | 83         |
| <b>Figure 6.9 – Reverse eaves soffit flashing .....</b>                                | <b>83</b>  |
| Figure 10.2 – Window head – Timber joinery with timber-framed wall insert .....        | 119        |
| Figure 10.3 – Window head – Aluminium joinery with timber-framed wall insert .....     | 120        |
| Figure 10.4 – Window head – Timber joinery with timber lintel .....                    | 121        |
| Figure 10.5 – Window head – Aluminium joinery with timber lintel .....                 | 122        |
| <b>Figure 10.6 – Window jamb – Timber joinery .....</b>                                | <b>123</b> |
| Figure 10.7 – Window jamb – Aluminium joinery .....                                    | 124        |
| <b>Figure 10.8 – Timber joinery with brick or tile sill .....</b>                      | <b>125</b> |
| Figure 10.9 – Window sill – Aluminium joinery with brick or tile sill .....            | 126        |
| 10.3 Arches .....  | 134        |
| <b>10.3.2 .....</b>  | <b>134</b> |

## Referenced documents

Reference is made in this document to the following:

### New Zealand standards

|                     |   |
|---------------------|---|
| NZS 1170.5: - - - - | Structural design actions   |
| Part 5 2005         | Earthquake actions – New Zealand  |
| NZS 3101:2006       | Concrete structures standard  |
| NZS 3104:2003       | Specification for concrete production   |
| NZS 3109:1997       | Concrete construction   |
| NZS 3504:1979       | Specification for aluminium windows   |
| NZS 3603:1993       | Timber structures standard  |
| NZS 3604:2011       | Timber-framed buildings   |
| NZS 3610:1979       | Specification for profiles of mouldings and joinery   |
| NZS 3619:1979       | Specification for timber windows  |
| NZS 3631:1988       | Timber grading rules  |
| NZS 4210:2001       | Masonry construction: Materials and workmanship   |
| NZS 4214:2006       | Methods of determining the total thermal resistance of parts of building  |
| NZS 4229: 2013      | Concrete masonry buildings not requiring specific design  |
| NZS 4251.1:2007     | Solid plastering - Cement plasters for walls, ceilings and soffits  |
| NZS 4297:2020       | Engineering design of earth buildings   |
| NZS 4298:2020       | Earth building materials and construction   |
| NZS 4402:- - - -    | Methods of testing soils for civil engineering purposes   |
| Test 2.2:1986       | – Soil classification tests – Test 2.2 Determination of the liquid limit  |
| Test 2.6:1986       | – Soil classification tests – Test 2.6 Determination of the linear shrinkage  |
| Test 6.5.2:1988     | – Soil strength tests – Determination of the penetration resistance of a soil – Hand method using a dynamic cone penetrometer |
| NZS 4404:2010       | Land development and subdivision infrastructure   |
| NZS 4431:1989       | Code of practice for earth fill for residential development   |

### Joint Australian/New Zealand standards

|                        |   |
|------------------------|---|
| AS/ NZS 1170: - - - -  | Structural design actions   |
| Part 0:2002            | General principles  |
| Part 1:2002            | Permanent, imposed and other actions  |
| Part 2:2021            | Wind actions  |
| Part 3:2003            | Snow and ice actions  |
| AS/NZS 1748.1:2011     | Timber – Solid – Stress-graded for structural purposes – General requirements |
| AS/NZS 2904:1995       | Damp-proof courses and flashings  |
| AS/NZS 2918:2018       | Domestic solid fuel burning appliances – Installation                         |
| AS/NZS 4455.1: - - - - | Masonry units, pavers, flags and segmental retaining wall units –             |
| Part 1:2008            | Masonry units   |
| AS/ NZS 4671:2019      | Steel reinforcing materials   |

### British standard

BS EN ISO 10319:2015 Geosynthetics. Wide-width tensile test

### American standard

ASTM E96/E96M-16 Standard test methods for water vapor transmission of materials

## Other publications

Cement and Concrete Association of New Zealand. CCANZ CP 01:2014 Code of practice for weathertight concrete and concrete masonry construction. Wellington: Cement and Concrete Association of New Zealand, January 2014. Available at: [https://concretenz.org.nz/page/CP01\\_terms](https://concretenz.org.nz/page/CP01_terms)

[CSIRO Australia Bulletin 5 Fourth Edition 1987: Earth Wall Construction](#)

EQC, MBIE, MfE. *Planning and engineering guidance for potentially liquefaction-prone land: Resource Management Act and Building Act aspects*. September 2017. Retrieved from: <https://www.building.govt.nz/assets/Uploads/building-code-compliance/b-stability/b1-structure/planning-engineering-liquefaction.pdf> (17 February 2020).

[Ministry of Business, Innovation, and Employment Acceptable Solution C/AS1 \[10 April 2012 updated to include amendments 1 to 5\]: Acceptable Solution for Buildings with Sleeping \[residential\] and Outbuildings \[Risk Group SH\]](#).

MBIE. *Repairing and rebuilding houses affected by the Canterbury earthquakes*. December 2012, updated May 2018. Retrieved from: <https://www.building.govt.nz/building-code-compliance/canterbury-rebuild/repairing-and-rebuilding-houses-affected-by-the-canterbury-earthquakes/> (17 February 2020).

New Zealand Concrete Masonry Association Inc. May 2011 New Zealand concrete masonry manual. Available at: [www.nzcma.org.nz/manual.html](http://www.nzcma.org.nz/manual.html).

New Zealand Geotechnical Society Inc. Field description of soil and rock – Guideline for the field classification and description of soil and rock for engineering purposes. Wellington: New Zealand Geotechnical Society, 2005. Available at: <https://www.nzgs.org/libraries/field-description-of-soil-and-rock/>

See Appendix A for a list of related documents used to prepare this standard.

## New Zealand legislation

Building Act 2004

Local Government Act 2002

New Zealand Building Code (NZBC)

Resource Management Act 1991

## Websites

[www.building.govt.nz](http://www.building.govt.nz)

[www.earthbuilding.org.nz/](http://www.earthbuilding.org.nz/)

[www.legislation.govt.nz](http://www.legislation.govt.nz)

## Latest revisions

The users of this standard should ensure that their copies of the above-mentioned New Zealand standards are the latest revisions. Amendments to referenced New Zealand and joint Australian/New Zealand standards can be found on [www.standards.govt.nz](http://www.standards.govt.nz).

## Review of standards

Suggestions for improvement of this standard will be welcomed. They should be sent to the Manager, Standards New Zealand, PO Box 1473, Wellington 6140.



## Foreword

The first edition of this suite of three standards, NZS 4297, NZS 4298 and NZS 4299, published in 1998 and updated in 2020, has been a core resource for building consent authorities determining compliance with the New Zealand Building Code (NZBC) and has given guidance to designers, builders, owner-builders, and others involved in the construction of successful earth walled buildings in New Zealand, and elsewhere around the world. There has been no failure reported to date of any earth building built in accordance with this suite of standards.

Earth walled construction continues to be relevant at a time when the sustainability and decarbonising of the built environment is under scrutiny. Earthen materials are minimally processed, have low toxicity, and are available locally. These standards will encourage and enable the uptake of local earthen materials with very low embodied energy within a decarbonising building industry.

The revised standards continue to be a core resource and reflect advances in earth building practice, research, changes in referenced standards, and changes in building legislation: the Building Act 2004 and the NZBC. They have been prepared [to support users in demonstrating compliance with NZBC clauses B1 Structure, B2 Durability, C1–C6 Fire safety, E2 External moisture, E3 Internal moisture and H1 Energy efficiency](#). Commentary clauses are provided throughout to explain methodologies and provide additional information.

Low-density earth building materials, which provide improved thermal and seismic performance, are included in the revised standards, along with the more traditional, dense earthen materials. [Acceptable Solution E2/AS2 third edition amendments 4 and 5 to the 1998 standards are now incorporated into these standards](#)

NZS 4297:2020 *Engineering design of earth buildings* is intended for use by structural engineers. Many of the structural design principles are chosen to be similar to those for unreinforced and reinforced masonry and reinforced concrete, and it is assumed that users of this standard will have a knowledge of design in these materials. However, earth has unique characteristics that need to be considered apart from other forms of masonry.

NZS 4299 (as described below) is primarily aimed at regular typical house configurations and includes careful expert consideration of the required detailing. Buildings that need engineering consideration to NZS 4297 because they are marginally outside the scope of NZS 4299 will need to include consideration for plan eccentricity, wall irregularity, structural continuity, and stiffness compatibility of load-carrying elements. The structure should be modified as necessary but maximise the use of the typical NZS 4299 details. Where there are unusual types of load, or major changes to NZS 4299 type building form, engineers need a comprehensive understanding of earth materials and significant earth building design experience.

NZS 4298:2020 *Materials and construction for earth buildings* sets out requirements for the use of unfired earth in the form of adobe, cob, pressed earth brick, rammed earth, and poured earth. It applies to buildings that are designed in accordance with NZS 4297 or NZS 4299.

Commentary to this standard takes heed of the long history of successful earth building worldwide. It is necessary to demonstrate that earthen materials used (with or without admixtures) produce results that meet at least the minimum standards of strength and durability. Tests and the required results are detailed so that assurance can be given that the earth building material will meet NZBC requirements.

NZS 4299:2020 *Earth buildings not requiring specific engineering design* is the earth building equivalent of NZS 3604 *Timber-framed buildings* but with its coverage limited to foundations, floor slabs, and walls including internal earth brick veneers. This revision covers single-storey reinforced earth walled buildings only. Two-storey buildings, unreinforced earth walled buildings, and other more ambitious structures are not included and require specific engineering design (SED). Durability and weathertightness are covered by a methodology that relates required durability test results to wind-driven rain exposure of any particular building site.

This revised edition of NZS 4299 includes new and informative appendices intended to give guidance on the placement and finishing of straw bales and light earth method (LEM) material within specifically designed timber walls as additional substrates for the earth and lime plasters that are also now covered by this standard. The use of some unpublished work, and the assistance of various practitioners from New Zealand and overseas while developing these appendices is acknowledged.

The materials covered by NZS 4297, NZS 4298, and NZS 4299 have been expanded to cover a variety of earth building techniques with material densities that range between dense rammed earth materials at 2200 kg/m<sup>3</sup> down to straw bales at 90 kg/m<sup>3</sup>. The range of density of materials, as well as the inclusion of a section on internal veneers of earth bricks, gives designers a wide range of options for selecting materials either for thermal mass, or insulation, or somewhere in between.

The inclusion of many drawings of construction details that have been proven in the New Zealand setting is intended to help builders in earth to achieve durable, weathertight, and successful buildings. This will

encourage the uptake of local earthen materials with very low embodied energy within a decarbonising building industry.

Completion of this standard has been undertaken by a partnership between Standards New Zealand and the Earth Building Association of New Zealand (EBANZ). The role of all members of the standards development committee (a committee that includes some members and the chair of the 1998 committee), their nominating organisations, of Standards New Zealand, and of EBANZ in the success of this collaborative process is acknowledged. Thanks go to EBANZ for the research and fundraising that enabled this project to progress, and to Martin Ulenberg for his work on the diagrams, and to all those from within New Zealand and overseas who offered support or made donations of time or money for this project, including Te Kāhui Whaihanga | New Zealand Institute of Architects. Particular thanks are given to the Development Lead, Ian Brewer, for all his administrative and editing work.

The 2024 limited-scope revision has been carried out by the reconvened standards committee in conjunction with MBIE to make relevant parts of this standard suitable for consideration as references within Acceptable Solutions and Verification Methods for selected clauses of the NZBC, to amend some technical points in light of new information, and to correct some typographical errors.

## Outcome statement

NZS 4299 sets a minimum standard for the design and construction of earth buildings. When applied by architects, designers, builders, engineers, apprentices, building consent authorities, and building industry regulators, NZS 4299 provides these users with cost-effective and practical [specifications and guidance information](#) for designing and constructing earth buildings, without the need for specific engineering design.

NZS 4299 provides prescribed methods for the design and construction of reinforced earth walled buildings including domestic dwellings and other residential buildings, and some commercial buildings that fit into 1.1 Scope and 1.2 Limitations.

It is intended that NZS 4299 will be [considered for referencing in Acceptable Solutions and Verification Methods which demonstrate](#) compliance with the NZBC so that it will provide [designers, building control officers and builders with a clear methodology for substantiating building consent and code compliance certificate applications](#).

NZS 4299 needs to be read and applied alongside NZS 3604, which provides the wind loading for earth buildings (where needed). NZS 3604 also provides design details for timber roofs, internal walls, and support framing for houses with internal earth veneers (which are modified by this standard).

NZS 4299 also needs to be read and applied alongside NZS 4298 for practical guidance on the materials, their testing, and how to use them when constructing successful earth buildings.

## 1 SCOPE AND INTERPRETATION

### 1.1 Scope

#### 1.1.1 Construction materials

This standard is principally intended for single-storey detached dwelling single-household unit buildings. Adjoining terraced single-household unit constructions are also possible.

This standard sets out construction requirements for adobe brick, cob, pressed earth brick, or rammed earth buildings, within the limitations of 1.2, not requiring specific engineering design (SED). Earth building materials density ranges from 800 kg/m<sup>3</sup> to less than 1400 kg/m<sup>3</sup> for low-density earth, and from 1400 kg/m<sup>3</sup> to 2200 kg/m<sup>3</sup> for heavy earth.

This standard also includes sections on internal earth veneer attached to light timber framing, surface finishes, and earth floors.

#### C1.1.1

*Many of the clauses and tables in this standard contain specific or implied limitations. The use of values other than those given by the clauses and tables does not comply with this standard. Furthermore, this standard does not cover all of the requirements of the NZBC. This standard provides solutions within a specified range that can lead to some provisions being in excess of what would be provided for by SED.*

*Particular details, materials, or methods of earth building construction that are not covered by this standard are not necessarily disallowed but are outside its scope as a means of compliance with the NZBC. Note that poured earth, although within the scope of NZS 4298, is not within the scope of this standard. If such aspects are incorporated in a building consent application then they will be treated as an alternative solution to the NZBC and need to be to the satisfaction of the territorial authority.*

#### 1.1.2 Support for demonstrating New Zealand Building Code compliance

For buildings within its scope, this standard supports the demonstration of compliance with certain requirements of the New Zealand Building Code (NZBC).

#### C1.1.2

*This standard supports compliance with NZBC clauses listed below.*

*Refer to Acceptable Solutions and Verification Methods published by the Ministry of Business, Innovation and Employment (MBIE) for information on whether conformance to this standard is deemed to demonstrate compliance with any of these NZBC clauses.*

*Clause B1 Structure: The provisions of this standard for earth walls and floors have been written to take account of the requirements of NZBC clauses B1.3.1, B1.3.2, and B1.3.4, in relation to actions arising from gravity, snow, earthquake, wind, impact, and time-dependent effects.*

*Clause B2 Durability: The provisions of this standard for earth walls and floors have been written to take account of the requirements of NZBC clause B2.3.1(a).*

*Clauses C1 to C6 Protection from fire.*

*The provisions of this standard which relate to heavy earth walls enable construction which Experimental Building Station, Chatswood, NSW, Technical Record 490 and AST E119 Fire Resistance Performance - Mono-Density Cob Wall indicate could achieve a fire resistance rating (FRR) of at least 120/120/120. Fire resistance ratings are a component of achieving compliance with NZBC clauses C1–C6.*

*Clause E2 External Moisture: The provisions of this standard for external earth walls and for earth floors have been written to take account of the requirements of NZBC clause E2.3.2, E2.3.3 and E2.3.7 for external walls.*

*Clause E3 Internal Moisture: The provisions of this standard have been written to take account of the requirements of NZBC clauses E3.3.1 to E3.3.6.*

*Clause H1 Energy Efficiency: The provisions of this standard include a means of determining the thermal resistance (R-value) of external earth walls. The thermal resistance of walls is a component in achieving compliance with NZBC clause E3.3.1, H1.3.1, and H1.3.2E.*

### 1.1.3 Informative appendices on light earth method walls and straw-bale walls

Light earth method (LEM) walls in accordance with [Appendix D](#) and straw-bale walls in accordance with [Appendix E](#) do not provide complete means of compliance with clauses B1, B2, E2, and H1 of the NZBC but provide information that can be part of compliant designs.

Such walls shall not be incorporated into earth walled buildings in accordance with the remainder of this non-SED standard.

Any building incorporating straw bale or light earth method (LEM) walls is to be the subject of SED.

### 1.1.4 Non-specific or unquantified terms

Where this standard has provisions that are in non-specific or unquantified terms (such as where provisions are required to be appropriate, adequate, suitable, and the like), then these do not form part of the means of compliance with the NZBC and shall be to the approval of the building consent authority.

Also, where reference is made in this standard to 'the manufacturer's recommendations or instructions' or similar, these are outside the scope of this standard as an acceptable solution to the NZBC and shall be to the satisfaction of the building consent authority.

Where this standard requires SED then this is outside the scope of the standard as an acceptable solution to the NZBC and shall be to the satisfaction of the building consent authority.

### 1.1.5

This standard does not provide complete information on the use of timber components and reference to NZS 3604 is required.

Where a building or part of a building does not comply with [1.2](#) it can be subject to SED to show compliance with the NZBC.

## 1.2 Limitations

Earth walled buildings, or aspects of them, that do not comply with the limitations in this section shall be subject to SED.

### C1.2

*NZS 4297 provides a design method for earth walled buildings that do not comply with some of the limitations of 1.2.*

This standard applies to buildings within the following limitations:

- (a) Buildings shall be limited to those of importance levels 1 and 2 of Table 3.2 of AS/NZS 1170.0 (see Table 1.1);
- (b) The design wind speed at the ultimate limit state for the building site, as determined in accordance with this standard, shall not exceed 50 metres per second (not exceed VH wind as defined in NZS 3604);

### C1.2(b)

*Generally, wind loadings on heavy earth walls may be disregarded for structural design and the design wind speed need not be calculated except in mountainous areas and other areas where there are conditions likely to cause local wind accelerations, including valleys and gorges shaped to produce funnelling of the wind, bluffs, very exposed hillsides, peaks, and ridges. If there is doubt about design ultimate limit state wind speed not exceeding 50 m/s then reference should be made to SED methods.*

*Wind loadings might need to be considered for buildings with low-density earth walls. Refer to section 4 'Bracing demand'.*

*The wind zone will need to be determined in accordance with 2.3 to determine weather protection from 2.7.*

- (c) The site shall be located or built up such that under severe flood conditions water does not rise above the level of the underside of the floor slab. Determination of these levels is outside the scope of this standard. Sea level rise shall be taken into account when determining site suitability;

**C1.2(c)**

*In order to comply with 1.2(c) and the minimum height of the floor above finished*

*ground level as specified in 5.2.3 refer also to E1.3.2 noting that the minimum height of the floor level is to be measured to the underside of the floor slab rather than finished floor level (FFL).*

*Flood waters can destroy adobe or lightly stabilised earth wall materials that are inundated for more than short periods. This could lead to overall structural collapse. More care is needed in siting earth wall buildings than for conventional construction.*

*Some situations to which special consideration should be given include:*

- (a) Height above river or stream flood level;*
- (b) Flood paths on sloping ground;*
- (c) Adequate drainage to prevent overland flow accumulation or diversion;*
- (d) Height above maximum storm wave upwash combined with maximum likely water levels on lakes or sea.*
- (e) The 100-year sea level rise as defined by some local authorities.*

- (d) The depth of compacted fill beneath a floor slab or foundation to the cleared ground level shall not exceed 600 mm;

**C1.2(d)**

*Where fill is required in excess of 600 mm deep the foundation will become an SED structure.*

- (e) The cleared ground level under the floor shall be level with or above the cleared ground level outside the building;
- (f) The cleared ground level shall be a minimum width of 1.0 m around the outside of the building;
- (g) The ground snow load as determined from NZS 3604 shall not exceed 2.0 kPa;

**C1.2(g)**

*In general 1.2(g) will be satisfied if the building is on a site where it will not be subjected to snow more than 500 mm deep (measured at ground level).*

- (h) The floor of the building shall be level. Earth buildings with a wing or block at a different floor level shall be designed as if the wing or block was a separate building. Otherwise, SED is required for earth buildings with different floor levels;
- (i) The average annual rainfall shall not exceed 3000 mm per year;
- (j) Some combinations of **roof overhang** protection, wall height, wind speed, and site exposure are excluded from the scope of this standard by 2.6;
- (k) Buildings shall be limited to single-storey buildings with a light roof with a maximum floor plan area of 600 m<sup>2</sup>;
- (l) Soil-bearing capacity and site profile requirements shall be in accordance with section 3 of this standard;
- (m) The site subsoil class for seismic considerations shall be as determined by 4.2;
- (n) Concrete foundations:
  - (i) Foundation members shall be continuous around the perimeter of the building
  - (ii) The foundations of external wing walls may extend outwards from the perimeter foundations by up to 1.2 m
  - (iii) Concrete foundation members under internal walls shall be connected to perimeter members at both ends if longer than 1.2 m but may be connected at one end only if shorter than 1.2 m;

**C1.2(n)**

*These requirements ensure interconnection of building elements at foundation level. A full ground floor slab is not required for this purpose.*

- (o) A structural slab is not required at ground level; however, a wearing surface shall be provided to ensure at all times during the building's life that the minimum clearance specified in this standard between exterior finished ground level and internal floor level are maintained;
- (p) Where a concrete slab-on-ground is proposed it shall be constructed in accordance with NZS 3604 or NZS 4229;
- (q) Earth floors shall be in accordance with section 13;
- (r) Only fully reinforced walls are permitted in this standard except an internal brick veneer with a minimum thickness of 130 mm and maximum mass of 300 kg/m<sup>2</sup> in accordance with Appendix F of this standard;
- (s) This standard only applies to earthquake zones 1, 2, and 3 as defined in 4.2.2;

**C1.2(s)**

*Earth buildings in earthquake zone 4 are to be subject to SED.*

- (t) Maximum earth wall height measured from the top of the reinforced concrete foundation (not including unreinforced nibs or fired bricks) to the underside of the top plate or bond beam shall be as follows:
  - (i) The height of earth walls with a straight-line top edge shall be limited to a maximum of 3.05 m in earthquake zones 1 and 2, and 2.75 m in earthquake zone 3
  - (ii) The height of earth gable walls with a single apex shall be limited to a maximum of:
    - (A) 3.6 m in earthquake zone 1
    - (B) 3.3 m in earthquake zone 2
    - (C) 3.05 m in earthquake zone 3 (Refer to Figure 1.1);
- (u) The thickness of earth walls, except internal brick veneer walls, shall be limited to between 280 mm and 450 mm;

**C1.2(u)**

*Earth walls are a minimum of 280 mm thick to provide adequate structural performance.*

- (v) Earth density:
  - (i) The density of low-density earth walls shall be limited to a range from 800 kg/m<sup>3</sup> to 1400 kg/m<sup>3</sup>
  - (ii) The density of heavy earth walls shall be from 1400 kg/m<sup>3</sup> up to 2200 kg/m<sup>3</sup>;
- (w) Roofs:
  - (i) Roof construction shall be limited to a light roof as defined in 1.5
  - (ii) The roof slope shall not be steeper than:
    - (A) 45° for roofs with a level ceiling diaphragm, or
    - (B) 25° for roofs with a roof plane diaphragm, or
    - (C) 25° for roofs with timber bond beams and no diaphragm in earthquake zone 1 only, and in earthquake zones 1, 2, and 3 with a concrete bond beam and no diaphragm
  - (iii) The height of a hip roof and a roof with a timber gable end wall shall be restricted to 3.6 m from the top of the foundation to the ridge of the roof
  - (iv) Roofs shall be of light timber construction complying with the relevant requirements of NZS 3604, unless otherwise modified by this standard, or designed using SED, provided they will be light roofs;
  - (v) Roof trusses shall be of 8.0m maximum span. The loaded dimension of a lintel supporting a truss as shown in Figure 9.1 shall not exceed 7.53 m;
- (x) Timber-framed walls designed to NZS 3604 that are not used as part of the bracing are permitted;
- (y) Suspended timber floors are outside the scope of this standard;

**C1.2(y)**

*The ventilation requirements for suspended timber floors would necessitate SED.*

(z) Buildings shall be ventilated to the requirements of Acceptable Solution G4/AS1.

**C1.2(z)**

*Good ventilation works in conjunction with the hygroscopic nature of earth walls to control the high airborne moisture loads that can occur in service rooms such as kitchens and bathrooms where moisture is generated.*

*In properly ventilated service rooms, condensation is unlikely to form because the earth walls can moderate humidity by absorbing excess water vapour harmlessly and release it when conditions reverse.*

*It is not good practice, and is outside the scope of this standard, to seal the walls in earth buildings, except within splash zones (surfaces adjacent to sanitary fixtures and sanitary appliances, and other surfaces likely to be splashed or become contaminated in the course of the intended use of the building) in service rooms. Sealing the walls would prevent the hygroscopic earth from being able to cope so well with excess humidity if this should arise in these areas, leading to the possibility of moisture condensation on the walls and subsequent promotion of the growth of mould, and is therefore detrimental.*

**Table 1.1 – Importance levels of buildings**

| Importance level                                   | Description   |
|--|---|
| <b>Building types covered by this standard</b>     |   |
| 1  | Structures of a secondary nature  |
| 2  | Single-family dwellings and structures not in other importance levels           |
| <b>Building types not covered by this standard</b> |   |
| 3  | Structures that may contain crowds or contents of a high value to the community |
| 4  | Structures with special post-disaster functions                                 |
| 5  | Special structures  |

(Based on Table 3.2 of AS/NZS 1170.0 – see 1.2(a))

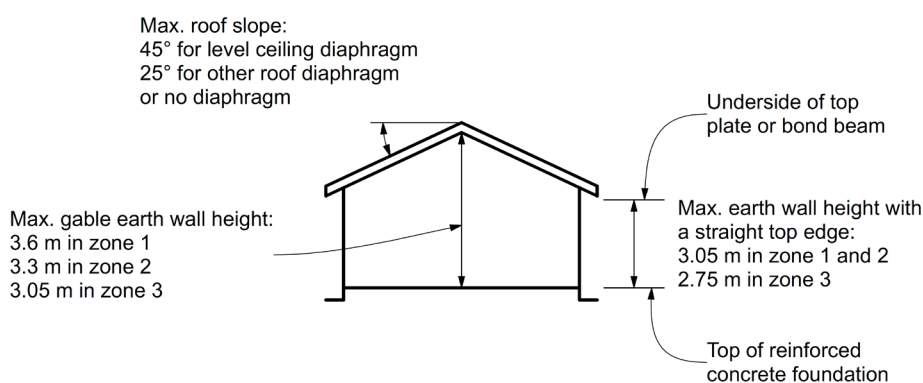

**A Height limitation for earth wall gable ends**

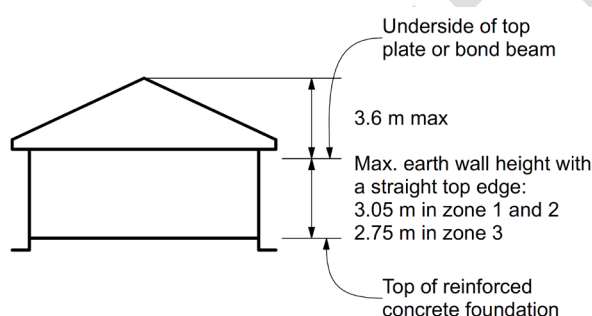

**B Height limitations roofs or timber-framed gable ends**

**Figure 1.1 – Height limitations**

## 1.3 Building components

### 1.3.1

Buildings constructed in accordance with this standard may incorporate structural components of earth, reinforced concrete, and timber. The timber components shall be in accordance with NZS 3604 except for those modifications to floor, lintel, and roof construction provided by this standard.

### 1.3.2

Systems to resist vertical loads shall be the following:

- (a) Footings to earth walls shall be in accordance with section 5;
- (b) Walls:
  - (i) Internal and external earth walls shall be in accordance with section 6
  - (ii) Internal timber-framed walls not providing bracing shall be in accordance with NZS 3604
  - (iii) A post and beam frame supporting the roof are outside the scope of this standard and will require specific design;
- (c) Lintels:
  - (i) Reinforced concrete lintels shall be in accordance with section 9
  - (ii) Timber lintels to support light timber frame shall be in accordance with section 9 or NZS 3604
  - (iii) Timber lintels supporting earth walls shall be in accordance with section 9;
- (d) Light timber roof and ceiling structure shall be in accordance with NZS 3604, and any structural diaphragms shall be in accordance with section 7 of this standard;
- (e) Arches shall comply with 10.3.



### 1.3.3

Systems to resist horizontal loads shall be as follows:

- (a) Internal and external walls shall be in accordance with section 4;
- (b) Bond beams of timber or reinforced concrete shall be in accordance with section 8;
- (c) Structural diaphragms of timber supporting earth walls shall be in accordance with section 7.

### 1.3.4

Systems incorporating different earth types or densities and bracing walls of other materials shall be subject to SED.

## 1.4 Interpretation

### 1.4.1

For the purposes of this standard, the word 'shall' identifies a mandatory requirement for compliance with the standard. The word 'should' refer to practices that are advised or recommended.

### 1.4.2

Clauses prefixed by 'C' and printed in italic type are intended as comments on the corresponding mandatory clauses. They are not to be taken as the only or complete interpretation of the corresponding clause, nor shall they be used for determining in any way the mandatory requirements of compliance with this standard. The standard can be complied with if the comment is ignored.

### 1.4.3

Where any clause in this standard contains a list of requirements, limitations, conditions, or the like, then each and every item in that list is to be adopted in order to comply with this standard unless the clause specifically states otherwise.

### 1.4.4

The full titles of referenced documents cited in this standard are given in the list of referenced documents immediately preceding the foreword.

### 1.4.5

The term 'informative' has been used in this standard to define the application of the appendix to which it applies. An 'informative' appendix gives additional information and is only for guidance. It does not contain requirements.

### 1.4.6

Unless inconsistent with the context, and subject to 1.4, terms defined in the NZBC shall have the same meaning in this standard.

### 1.4.7

Earth components shown in the figures are diagrammatic and do not necessarily represent the actual component shape.

## 1.5 Definitions

For the purposes of this standard the following definitions shall apply:

- (a) Timber definitions are contained in NZS 3604;
- (b) Earth building definitions are contained in this standard.

Where terms are used only in relation to light earth method (LEM) they are defined in Appendix D and where they relate only to straw-bale construction they are defined in Appendix E.

|                                   |  |
|-----------------------------------|--|
| <b>Adobe</b>                      | An air-dried brick made from a puddled earth mix cast in a mould and which contains a mixture of clay, sand, silt, and aggregate. The mix sometimes contains a small proportion of straw or a stabiliser. Also known as mudbrick.  |
| <b>Aggregate</b>                  | Collective name for inert materials such as sand and gravel, which when mixed with clay, and possibly additional binding agents or fibres, is used to produce earth-based building materials. Silt may also be present as an inert filler.   |
| <b>Anchorage nut</b>              | <a href="#">A galvanised steel nut within a reinforcing anchorage assembly that is tightened in accordance with section 6</a>  |
| <b>Anchorage washer</b>           | <a href="#">A square galvanised steel washer within a reinforcing anchorage assembly that is used to transfer post-tensioning anchorage forces into timber and concrete bond beams</a>   |
| <b>Bond beam</b>                  | <a href="#">The bond beam is the structural item, timber, or concrete, that contributes towards the lateral stability of the wall and includes the timber or concrete element with or without a structural diaphragm fixed to it.</a>  |
| <b>Bracing</b>                    | Any method employed to provide lateral support to a building   |
| <b>Bracing capacity</b>           | Strength of bracing of a whole building or of elements within a building. Bracing capacity is measured in bracing units (BUs) and shall be determined from section 6   |
| <b>Bracing demand</b>             | The horizontal forces resisted by a whole building or by an element within a building. These horizontal forces are a result of wind or earthquake action. Bracing demand forces are measured in bracing units (BUs). They are determined as set out in section 4 for earthquake and wind actions |
| <b>Bracing line</b>               | A line along or across a building for controlling the distribution of wall bracing elements  |
| <b>Bracing panel</b>              | A panel section of earth in a structural wall of solid plan length (with no openings) that gives lateral stability to the building   |
| <b>Bracing unit (BU)</b>          | A bracing unit is a measure of:<br>(a) The horizontal force (bracing demand) on the building (1 kN – kilonewton – is equal to 20 bracing units);<br>(b) The resistance to horizontal force (bracing capacity) of building elements   |
| <b>Building consent authority</b> | A building consent authority as defined in the Building Act and includes a territorial authority or other body registered as such under the Building Act   |
| <b>Clay</b>                       | A fine-grained, natural, inorganic soil composed primarily of hydrous aluminium silicates with grain diameters less than 0.002 mm  |
| <b>Cob</b>                        | A method of earth construction that involves placing a stiff mix of moist, unstabilised clay, silt, and sand directly into place in walls without the use of formwork or mortar. The mix may also contain, gravel, straw, other fibres, pumice or perlite  |
| <b>Compressive strength</b>       | A physical property of a material that indicates its ability to withstand compressive forces, usually expressed in kPa or MPa  |

|  |  |
|--|--|
| <b>Construction joint (in earth walls)</b> | Joint made within a rammed earth wall panel during the production of the wall as a result of the stepwise building procedure   |
| <b>Control joint</b>                       | A joint necessary to allow an earth wall to expand and contract or otherwise move  |
| <b>Damp-proof course (DPC)</b>             | A layer of durable water-vapour barrier material placed between building elements to prevent the passage of moisture from one element to another   |
| <b>Damp-proof membrane (DPM)</b>           | Sheet material, or coating, having low water-vapour transmission, used to minimise water and water-vapour penetration into or within buildings   |
| <b>Density</b>                             | Unless otherwise specified, refers to the cured in-situ mass per cubic metre of the earth wall material, determined by the methodology of NZS 4298, Appendix M. The in-service moisture content should be between 3% and 6%  |
| <b>Diaphragm</b>                           | A building element such as a floor or ceiling capable of transferring loads in its own plane to boundary members   |
| <b>Dry density</b>                         | The density determined by the methodology of NZS 4298, Appendix M, at an in-service moisture content of between 3% and 6%  |
| <b>Durable</b>                             | Resistant to wear and decay. Durability has a corresponding meaning  |
| <b>Earth</b>                               | (For earth building) Natural subsoil comprised of clay plus varying percentages of silt, sand, and gravel that is unfired and is free of significant organic matter other than apart from that allowed in NZS 4298   |
| <b>Eave</b>                                | <a href="#">The eave is a horizontal or sloping roof overhang above an exterior wall. See verge and roof overhang</a>  |
| <b>Erosion</b>                             | The physical and chemical processes by which earth building material is worn away. It includes the processes of weathering and mechanical wear   |
| <b>Footing</b>                             | That portion of a foundation bearing on the ground and any adjoining portion that is reinforced so as to resist the bearing forces. A footing may be spread out to provide an increase in bearing area or an increase in stability   |
| <b>Foundation</b>                          | Those parts of a building, transmitting, and distributing loads to the ground through a footing  |
| <b>Foundation wall</b>                     | See definition of Wall   |
| <b>Framing timber</b>                      | Timber members to which lining, cladding, or decking is attached, or which are depended upon for supporting the structure or for resisting forces applied to it  |
| <b>Gable</b>                               | Outside wall between the planes of the roof and the line of the eaves  |
| <b>Gable height</b>                        | The height from the top of the lower connected wall to the apex of the gable wall  |
| <b>Good ground</b>                         | Any soil or rock conforming with 3.1 that is capable of permanently withstanding an ultimate bearing capacity of 300 kPa (that is, an allowable bearing pressure of 100 kPa using a factor of safety of 3), but excludes potentially compressible or liquefaction-prone ground, expansive soils, and ground that could foreseeably experience movement of 25 mm or greater resulting from the causes detailed in 3.1.1 |

|  |   |
|--|---|
| <b>Gringo Block</b>                        | A block of solid or made-up timber, or a timber frame that is filled with adobe or cob, about the size of an adobe brick, that is inserted into an adobe or cob wall to act as a fixing point. <i>(This is a term that comes from common usage in the USA)</i>  |
| <b>Ground level</b>                        | See finished ground level   |
| <b>Cleared ground level</b>                | The ground level after the site has been cleared and any site excavation has been completed but before building footings have been excavated. When topsoil is not stripped off a site, the cleared ground level shall be taken as the base of the topsoil layer   |
| <b>Finished ground level</b>               | The level of the ground against any part of a building after all backfilling and/or landscaping and/or surface paving has been completed  |
| <b>Natural ground level</b>                | The ground level before the site has been cleared   |
| <b>Heavy-weight earth (or heavy earth)</b> | Adobe, cob, pressed earth bricks, or rammed earth with a dry density greater than 1400 kg/m <sup>3</sup> and up to 2200 kg/m <sup>3</sup>   |
| <b>Joist</b>                               | A horizontal framing member to which is fixed floor decking or ceiling linings and which is identified accordingly as a floor joist or ceiling joist  |
| <b>Light earth method (LEM)</b>            | A mixture of light earth tamped in formwork to form an insulated wall between or around structural members and around wall openings. See Appendix D   |
| <b>Light earth</b>                         | A mixture of straw or other natural fibres and clay slip tamped to form an insulated wall between or around structural members and around wall openings. Also known as straw-clay, clay straw, light LEM, clay-fibre, straw light clay, light straw clay, or chip and slip. Other natural fibres such as wood shavings or reeds may be incorporated or substituted. Low-density mineral aggregates such as pumice or vermiculite may also be included |
| <b>Light roof</b>                          | A roof with roofing material (cladding and any sarking), having a mass not exceeding 20 kg/m <sup>2</sup> of roof area. Typical examples are steel, copper, and aluminium roof claddings of normal thickness, 6 mm thick cellulose cement tiles, 6 mm thick corrugated cellulose cement, and the like, without sarking  |
| <b>Lime</b>                                | Quicklime or burnt lime (CaO) or hydrated (slaked) lime (Ca(OH <sub>2</sub> )) but not agricultural lime (CaCO <sub>3</sub> ). Agricultural or gardening lime is crushed limestone or other calcium carbonate natural material and is not relevant to earth building apart from occasional use as a sand or gravel aggregate  |
| <b>Lintel</b>                              | A horizontal member spanning an opening in a wall   |
| <b>Load</b>                                | Loads are considered to include gravity loads (for example dead and live), earth pressure, earthquake, wind and human impact<br><br>NOTE – Loads are referred to as actions in the AS/ NZS 1170 suite of standards. In AS/NZS 1170 dead load is referred to as permanent action and live load is referred to as imposed action  |
| <b>Loadbearing</b>                         | An element that provides resistance to loads other than those induced by the weight of the element itself   |

|  |   |
|--|---|
| <b>Low-density earth (also known as low density earth) includes structural light adobe (SLA) or structural light cob (SLC)</b> | Adobe or cob used structurally with a dry density of from 800 to 1400 kg/m <sup>3</sup>   |
| <b>Moisture content</b>  | The amount of water contained in soil or earth material expressed as the weight of the water divided by the weight of the dry soil or earth material in percentage terms  |
| <b>Natural ground level</b>  | The ground level before the site has been cleared   |
| <b>Number 1 framing</b>  | A structural grade of exotic softwood (New Zealand grown or imported) as specified by NZS 3631  |
| <b>NZBC</b>  | New Zealand Building Code   |
| <b>Plaster</b>   | Material used for providing a thick coating as a protective or decorative layer to walls or ceilings. Sometimes called render when applied to exterior surfaces. Common exterior plasters are based on hydrated lime or cement/hydrated lime, and interior plasters include those made from earth, hydrated lime, or gypsum |
| <b>Plate</b>   | A horizontal or raking timber member in a wall that supports and distributes the load from floors, walls, ceiling, or roof  |
| <b>Pressed earth brick (or pressed brick)</b>  | An earth brick that is made in a mechanical press, either machine operated or hand operated   |
| <b>Rafter</b>  | A framing timber, normally parallel to the slope of the roof, providing support for sarking, purlins, or roof cladding  |
| <b>Rammed earth</b>  | Damp or moist earth, with or without stabiliser, that is rammed in place between temporary moveable formworks. Also known as pisé or pisé de terre  |
| <b>Rammed earth wall panel</b>   | A section of rammed earth wall being of full height of the finished section but of a length that is built at one stage  |
| <b>Reinforced earth construction</b>   | Any earth structure into which reinforcing is so bedded and bonded that the two materials act together in resisting forces  |
| <b>Roof</b>  | That upper part of the building having its upper surface exposed to the outside and at an angle of 45° or less to the horizontal (see also 1.2(j))  |
| <b>Roof, heavy</b>   | Outside the scope of this standard  |
| <b>Roof, light</b>   | See Light roof  |
| <b>Roof overhang</b>   | A generic term for an eave, verge, or verandah and is the edge or portion of the roof which overhangs the face of an exterior wall and projects beyond the side of a building. A horizontal or sloping roof overhang above an exterior wall. Roof overhangs include verandah roofs  |
| <b>R-value</b>   | The value of thermal resistance of a building element (for example wall, floor, or roof) that is the sum of the surface resistances on each side of a building element and the thermal resistances of each component of the building element including any cavities in the element (m <sup>2</sup> °C/W)                    |

|  |   |
|--|---|
| <b>Sand</b>                              | Individual rock or mineral fragments that range in size from the upper limit of silt (0.06 mm) to the lower limit of gravel (2.0 mm)  |
| <b>Sarking</b>                           | Sheet material or boards secured to rafters, trusses, or purlins, which may also serve as a ceiling lining or as a roof diaphragm   |
| <b>SED</b>                               | See Specific engineering design   |
| <b>Shrinkage</b>                         | The decrease in volume of earth material or mortar caused by curing or the evaporation of water. Expressed as a percentage of linear dimension  |
| <b>SI Units</b>                          | A unit of permeance measured in nanograms per second per square metre per pascal of water vapour pressure (ng/Pa.s.m <sup>2</sup> )   |
| <b>Side wall</b>                         | An earth external wall that does not contain a gable and is generally horizontal or may be raking at less than 10° (approximately 1:6)  |
| <b>Silt</b>                              | Individual mineral particles in a soil that range in size from the upper limit of clay (0.002 mm) to the lower limit of sand (0.06 mm)  |
| <b>Skillion roof</b>                     | A roof where the ceiling runs parallel to the roofing material  |
| <b>Slurry</b>                            | A mixture of earth and water that results in a soupy mixture that is easily poured  |
| <b>Soil</b>                              | The natural, undisturbed ground that is adjacent to and underlies buildings and also the source of raw materials for earth building construction. See Earth   |
| <b>Spacing</b>                           | The distance at which members are spaced measured centre to centre  |
| <b>Span</b>                              | The clear distance between supports measured along a member   |
| <b>Specific engineering design (SED)</b> | Requires calculation and design beyond the scope of this standard. The design required is not necessarily design by engineers but may include architects and licensed building practitioners in an appropriate area of practice                               |
| <b>Stabilisation</b>                     | The improvement of the performance of earth building material properties by the addition of materials that bind the earth particles. Stabilisation can increase the resistance of earth to moisture, reduce volume changes, or improve strength or durability |
| <b>Stabilised adobe</b>                  | Adobe bricks that have a stabiliser added, typically lime, cement, or asphalt emulsion  |
| <b>Stabilised rammed earth</b>           | Rammed earth that has had a stabiliser added, usually cement  |
| <b>Stabiliser</b>                        | A material that is used for stabilisation   |
| <b>Structural light adobe (SLA)</b>      | See Low-density earth; also known as structural light adobe (SLA) or structural light cob (SLC)   |
| <b>Structural light cob (SLC)</b>        | See Low-density earth; also known as structural light adobe (SLA) or structural light cob (SLC)   |

|                                       |   |
|---------------------------------------|---|
| <b>Territorial authority</b>          | A territorial authority defined in the Local Government Act 2002  |
| <b>Top plate</b>                      | The top plate is the element at the top of the earth wall that does not contribute towards lateral stability of the wall (e.g. a plate directly above a concrete bond beam that solely provides fixing for trusses or rafters)  |
| <b>Total thermal resistance</b>       | See R-value   |
| <b>Unreinforced earth wall</b>        | An earth wall containing less than the minimum reinforcement required by section 6 for reinforced earth walls. (This is outside the scope of this standard)   |
| <b>Veneer brick</b>                   | An interior skin of earth wall material of maximum mass of 300 kg/m <sup>2</sup> that is attached to and laterally supported by a structural wall of timber in accordance with Appendix F   |
| <b>Vertical reinforcing anchorage</b> | The post-tensioning anchorage assemblies that are installed at the tops of vertical reinforcing and tightened in accordance with section 6. Vertical reinforcing anchorages are required at timber and concrete bond beams on tops of earth walls and at tops of earth walls under openings |
| <b>Verge (or gable verge)</b>         | The roof overhang over a gable ended wall at the gable  |
| <b>Wall bracing panel</b>             | A section of wall above the ground level that performs a bracing function   |
| <b>Wall</b>                           |   |
| <b>External wall</b>                  | An outer wall of a building   |
| <b>Internal wall</b>                  | A wall other than an external wall  |
| <b>Loadbearing wall</b>               | A wall supporting vertical loading from floors, ceiling joists, roof, or any combination thereof  |
| <b>Non-loadbearing wall</b>           | A wall other than a loadbearing wall and that may contain bracing panels  |
| <b>Wall top plate</b>                 | A horizontal timber member on which rafters or roof trusses are supported   |
| <b>Wall structural wall</b>           | Any wall that because of its position and shape contributes to the rigidity and strength of the building  |
| <b>Wall thickness</b>                 | Minimum thickness of wall remaining after any chasing, raking, or tooling of mortar joints but excluding the surface coating, if any  |

## 1.6 Abbreviations

The following abbreviations are used in this standard.

|                        |   |
|------------------------|---|
| <b>AWBD</b>            | Additional wall bracing demand                        |
| <b>BU</b>              | Bracing units   |
| <b>DPC</b>             | Damp-proof course                                     |
| <b>DPM</b>             | Damp-proof membrane                                   |
| <b>EMC</b>             | Equilibrium moisture content                          |
| <b>HDPE</b>            | High-density polyethylene                             |
| <b>L, M, H, VH, EH</b> | Low, medium, high, very high, extra high (wind zones) |
| <b>LEM</b>             | Light earth method                                    |
| <b>NZBC</b>            | New Zealand Building Code                             |

|             |                                  |
|-------------|----------------------------------|
| <b>OS</b>   | Outside scope                    |
| <b>PIM</b>  | Project information memorandum   |
| <b>PVC</b>  | Polyvinyl chloride               |
| <b>SED</b>  | Specific engineering design      |
| <b>SLA</b>  | Structural light adobe           |
| <b>SLC</b>  | Structural light cob             |
| <b>uPVC</b> | Unplasticised polyvinyl chloride |

## 2 GENERAL

### 2.1 Materials

#### 2.1.1 Earth

Earth materials and construction shall comply with the provisions of NZS 4298 for standard grade earth construction.

Test procedures and results required are detailed in the appendices to NZS 4298.

Low-density earth and heavy earth may not be combined in one building unless subject to SED.

#### 2.1.2 Concrete

All concrete shall satisfy the requirements of NZS 3109 with a minimum specified strength of 17.5 MPa except as otherwise noted in this standard.

#### 2.1.3 Concrete masonry

Concrete masonry shall comply with the provisions of NZS 4210.

#### 2.1.4 Steel reinforcement

Reinforcing steel shall comply with Grade 300E or Grade 500E provisions of AS/NZS 4671:2019. Reinforcing steel mesh shall comply with Grade 500E provisions of AS/NZS 4671:2019.

Bar reinforcing steel shall be Grade 300 for all applications except concrete where Grade 500 is specified. Grade 500 may be substituted where Grade 300 is specified.

Bends, hooks, and other details of reinforcement shall be in accordance with NZS 3109.

Steel mesh for concrete slab reinforcement and/or cut for mortar joint reinforcement shall be type SE62 in accordance with AS/NZS 4671.

Mortar joint reinforcement shall be painted with zinc rich paint or asphalt emulsion.

#### **C2.1.4**

*In this document deformed reinforcing bars are designated 'D' or 'H' followed by the diameter in millimetres. Plain round reinforcing bars are designated 'R' followed by the diameter in millimetres.*

*In general, D12 bars are shown on the drawings where HD12 (Grade 500) may be used. Bars with hot rolled threads are generally available only in Grade 500.*

#### 2.1.5 Geotechnical mesh reinforcement

The use of polypropylene biaxial or triaxial geogrid in accordance with NZS 4298, clause 2.8.1.4, is permitted.

#### 2.1.6 Bolts

At bolted connections washers shall be provided at each timber surface under the bolt head or the nut. Bolts shall be engineering bolts, not coach bolts. Washers shall be of the following minimum sizes:

- (a) For M12 bolts – 50 mm square × 3 mm or 55 mm round × 3 mm;
- (b) For M16 bolts – 65 mm square × 5 mm or 75 mm round × 5 mm.

Where bolts or reinforcing bars in tension bear directly against earth construction or mortar, washers shall be provided in accordance with 6.4.4.4 and Figure 10.8, 10.9, 10.11 and 10.15.



### 2.1.7 Mortar

Mortar shall comply with the provisions of NZS 4298.

### 2.1.8 Timber

Timber in this standard for top plates, bond beams, and lintels shall be SG8 or better stress-graded timber in accordance with AS/NZS 1748:1 to sizes specified in this standard and shall comply with the durability requirements of 2.6.4.1 In some cases where modifying factors are provided, SG6 or No. 1 framing macrocarpa or cypress may be used.

### 2.1.9 Screws

Screws are designated by gauge in this standard and the approximate equivalent diameters in millimetres are given by Table 2.1.

**Table 2.1 – Screw sizes**

| Gauge    | 6   | 7   | 10  | 12  | 14  |
|----------|-----|-----|-----|-----|-----|
| Size, mm | 3.5 | 3.8 | 4.9 | 5.6 | 6.3 |

#### C2.1.9

*Different manufacturers provide slightly different diameters for each gauge.*

## 2.2 Methods of construction

This standard covers the following methods of earth building construction:

- (a) Rammed earth;
- (b) Adobe (heavy and low density);
- (c) Cob (heavy and low density);
- (d) Internal brick veneer (heavy and low density);
- (e) Pressed brick;
- (f) Earth floors.

#### C2.2

*Other earth building methods such as poured earth, in-situ adobe, and wattle and daub are not covered by this standard.*

*LEM and straw bale are included as informative appendices in this standard. Surface coatings including earth plasters, poured earth, and in-situ adobe have sections outlining their materials and construction in NZS 4298. Wattle and daub uses a cob mix applied within a timber lattice to SED.*

## 2.3 Wind zones for weather protection

Wind zones shall be determined from NZS 3604 with wind zones in accordance with Table 2.2. Wind speeds over 50 m/s (EH or SED wind zone to NZS 3604) require SED and are outside the scope of this standard.

**Table 2.2 – Wind speed zone designations**

| Zone           | Maximum design wind speed at ultimate limit state (m/s) |
|----------------|---|
| Low (L)        | 32  |
| Medium (M)     | 37  |
| High (H)       | 44  |
| Very high (VH) | 50  |

## 2.4 Wind zones for roof design

The wind zone for roofs in accordance with NZS 3604 shall be determined using NZS 3604.

## 2.5 Snow loads

Snow loads shall be determined in accordance with NZS 3604.

## 2.6 Durability

### 2.6.1 General

Compliance with this section is necessary to satisfy the requirements of clause B2 of the NZBC. Durability design is summarised in Figure 2.1.

### 2.6.2 Earth

#### 2.6.2.1

The earth wall material shall meet the acceptance criteria of the wet/dry appraisal test detailed in Appendix J of NZS 4298.

#### 2.6.2.2

The wind zone shall be as given by 2.3..

#### 2.6.2.3

The earth wall material erodibility index may be improved by stabilisation of the earth wall material by the addition of cement or lime, or by application of lime plaster. Surface coatings may be used but shall only improve the erodibility index by a maximum of 1 point. The improved or coated earth wall material shall be retested using the spray erosion test or the drip erosion test (Appendices K and L of NZS 4298) where appropriate to determine the improved earth wall erodibility index.

#### 2.6.2.4

The structural integrity of each wall panel shall be maintained through normal maintenance as required in 2.6.2.6. No continuous visual imperfection shall be more than one-tenth of the wall thickness and shall not exceed 300 mm in length and height. Total visual imperfections shall not exceed 2% of the area of any face of a wall panel.

#### 2.6.2.5 Mortar joint reinforcement durability

Steel horizontal mortar joint reinforcement referred to in 6.5 shall be galvanised or painted with zinc rich paint or coated with bitumen or asphalt paint and may be used in exposure zones B and C from Figure 2.2 and Figure 2.3.

In zone D only polypropylene mesh as specified in 6.6.3 may be used.

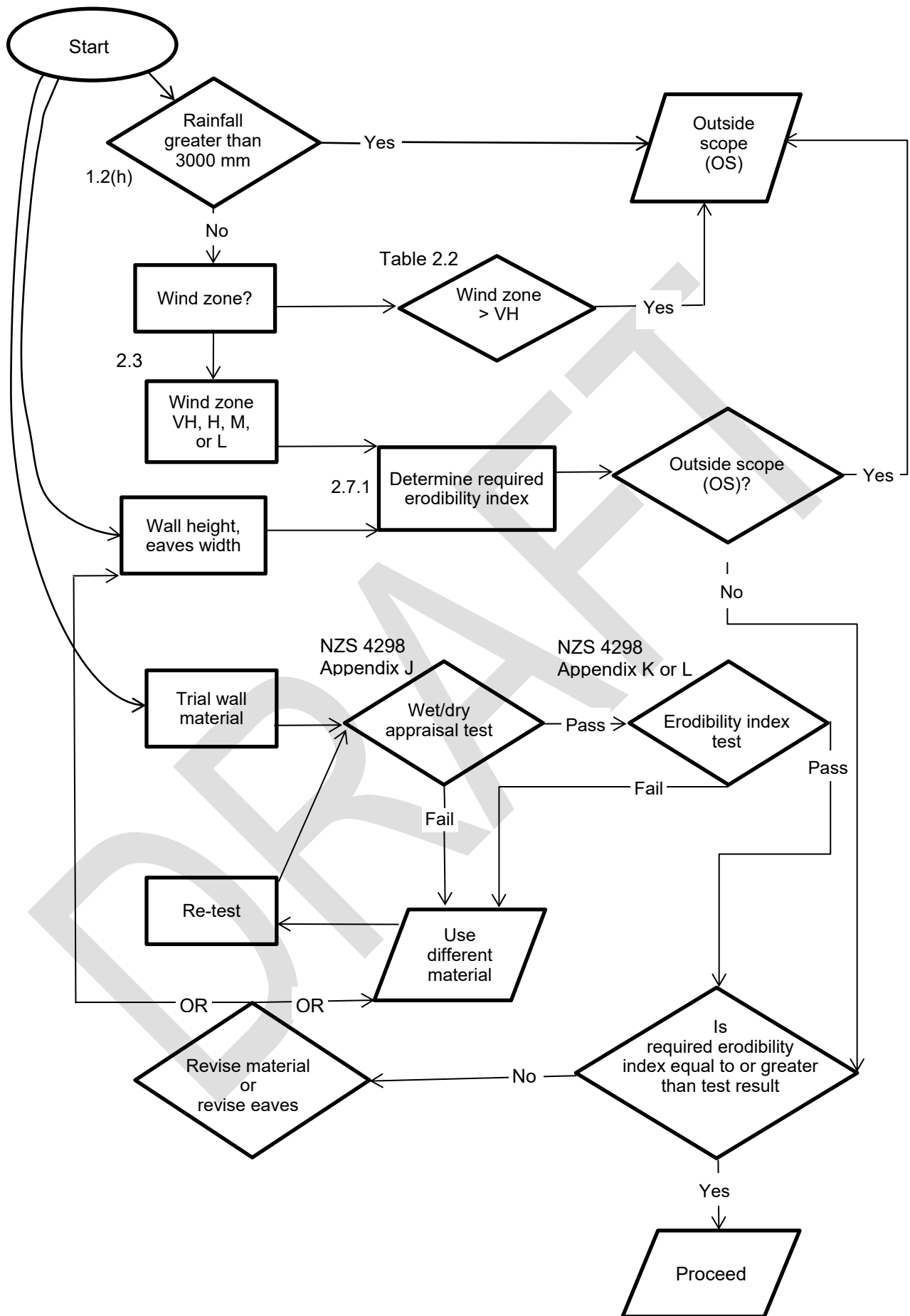

Figure 2.1 – Durability design

### 2.6.2.6 Earth wall maintenance

- (a) Normal maintenance shall include the following:
- (i) The repair of damage or deterioration of the wall surface including any surface coating, and
  - (ii) The removal of any source of moisture that is capable of causing localised elevation of earth wall moisture content. (Such sources include plumbing or roofing leaks, channelling of rainwater, bridging or other loss of integrity of the damp-proof course, vegetation, or build-up of ground levels), and
  - (iii) The maintenance or restoration of shelter that was taken into account when the original assessment of durability was made at the design stage;
- (b) Repair of earth building material shall be carried out using the same material as that from which the earth wall is constructed and shall be applied in accordance with NZS 4298;
- (c) Curing of lime or cement containing repair mixtures shall be carried out in accordance with the provisions of NZS 4298.

### 2.6.2.7

Maintenance shall be carried out in accordance with the Maintenance Schedule in Appendix G.

#### C2.6.2.7

*For more detail on maintenance and repair of earth walls built by different techniques refer to the relevant clauses in NZS 4298. See rammed earth Section 3, Adobe Section 4, Pressed earth brick Section 5, Cob Section 6, Poured earth and In-situ adobe Section 7 and Surface coatings Section 8.*

### 2.6.3 Corrosion protection of steel fixings and fasteners

Steel connections and fixings including nails, bolts, and nail plates, which are:

- (a) Exposed to the weather; or
- (b) In contact with earth wall or earth floor material; or
- (c) In contact with other building materials that are below any damp-proof membrane;

shall be hot dip galvanised or stainless steel. Plain steel fixings and fastenings may not be used in contact with earth. NZS 3604 durability provisions shall be used to determine whether hot dip galvanised, or stainless steel shall be used.

Areas of a building where windblown salt or sand can penetrate rain-protected areas such as subfloor, eaves, and roof spaces shall be designated as durability zone D when applying NZS 3604 durability provisions for steel fastenings and fixings in such locations.

Wall ties and their screws in earth brick veneer construction shall be galvanised.

#### C2.6.3

*The corrosion protection of metal fasteners for timber bond beams should not be overlooked.*

### 2.6.4 Timber durability

#### 2.6.4.1

Timber for lintels, top plates, and bond beams 2.7 shall be in accordance with NZBC B2/AS1 Durability.

#### C2.6.4.1

*Heartwood of naturally durable species has been used successfully for lintels, top plates and bond beams in earth buildings with roof overhangs prescribed in the previous standard that also aligns with this standard. This in service history could form the basis of showing compliance with NZBC B2 via the Verification Method B2/VM1.*

**2.6.4.2**

Install a damp-proof course (DPC) to separate timber from concrete, cement-stabilised earth, and lime-stabilised earth. DPC material shall be a coating as specified in 5.6.5 or moisture-sealing sheet material.

**C2.6.4.2**

*Lime plasters or renders, in contrast to lime-stabilised earth wall materials, may be in contact with timber. For example, this may occur around timber joinery facing boards, other types of external timber trim, junctions between lime renders and adjacent timber claddings, as well as to exposed timber lintels in lime rendered walls.*

**2.6.4 Concrete durability****2.6.5.1**

Minimum concrete cover to steel reinforcement shall be:

- (a) 75 mm when concrete is placed directly on or against the ground;
- (b) 50 mm in all other situations where the concrete is placed in formwork provided the concrete specification follows the requirements of 2.6.5.2;
- (c) 30 mm from the top of a wall or floor slab that is in an interior area or 50 mm from the top of any exterior wall or floor slab.

**2.6.5.2**

The minimum specified 28-day concrete strength, complying with NZS 3104 and NZS 3109 shall be:

- (a) 10 MPa for unreinforced concrete used in mass foundations;
  - (b) 17.5 MPa for unreinforced concrete applications, or reinforced concrete either not exposed to weather or exposed to the weather in zone B as shown in Figure 2.2 and Figure 2.3;
  - (c) 20 MPa for reinforced concrete exposed to weather in zone C as shown in Figure 2.2 and Figure 2.3;
  - (d) 25 MPa for reinforced concrete exposed to weather in zone D. Zone D is defined as within 500 m of the sea including harbours, or 100 m from tidal estuaries and sheltered inlets, and otherwise as shown in Figure 2.2 and Figure 2.3. The coastal area also includes all offshore islands including Waiheke Island and Great Barrier Island;
  - (e) Specially selected from NZS 3101 where a direct wearing concrete floor is required.
- Geothermal hot spots, defined as being within 50 m of a geothermal bore, mud pool, steam vent, or other source shall be to SED.

**C2.6.5.2**

*Concrete durability is known to increase with increasing cement content and increasing strength.*

*A lower strength concrete is permitted in bond beams and lintels by virtue of their good protection from the elements by the large overhangs specified for earth buildings elsewhere in the standards. 17.5 MPa concrete can be hand-mixed using 5.25 parts builder's mix to 1 part of cement (by volume) with just enough water to make it workable. If it is desired to hand-mix concrete of strength higher than 17.5 MPa, SED will be required.*

*Exposure zone descriptions (from NZS 3604):*

*Zone B: Low, includes inland areas with little risk from windblown sea-spray salt deposits.*

*Zone C: Medium, includes inland coastal areas with medium risk from windblown sea-spray deposits. This zone covers mainly coastal areas with relatively low salinity. The extent of the area varies significantly with factors such as winds, topography, and vegetation.*

*Zone D: High, includes coastal areas with high risk of windblown sea-spray salt deposit.*



Figure 2.2 – Exposure zone map (North Island)

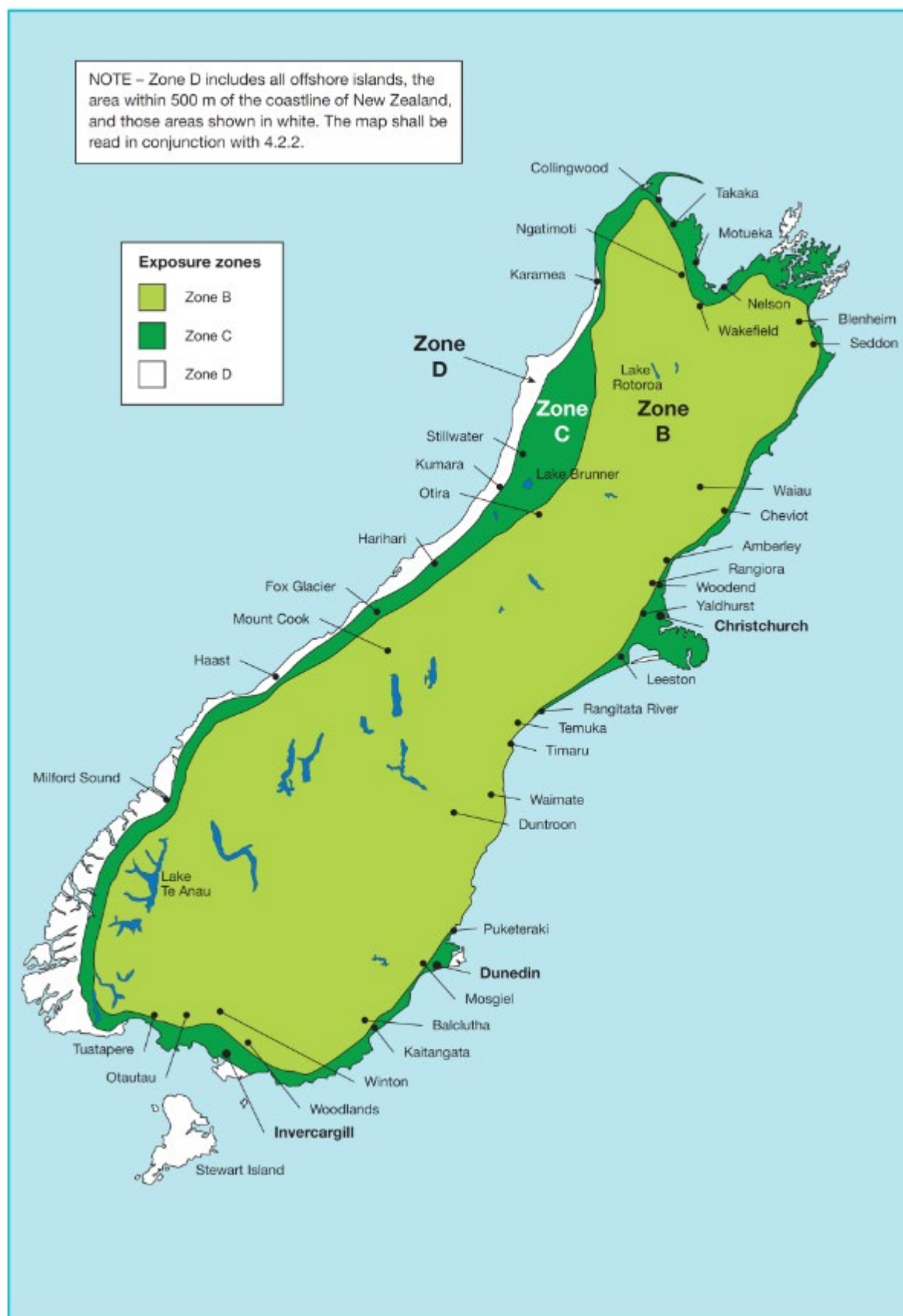

Figure 2.3 – Exposure zone map (South Island)

## 2.7 Weather protection

### C2.7

#### General

*The biggest risk factor to walls made of earth (or other moisture sensitive walls) from moisture that may cause damage comes from wind-driven rain.*

*Earth walls are single skin construction, so do not have several layers built in to the walls to control water or moisture impacting on them that many other building techniques such as timber-framed buildings have.*

*Rain hitting a solid wall will either be shed (fully face sealed and drained), absorbed (by capillary action), or will penetrate deeper by pressure differential. Therefore techniques to limit the risk from driving rain hitting a wall need to be deployed.*

*The methods for dealing with external moisture are founded on the four principles of deflection, drainage, drying, and durability (the 4Ds).*

#### Deflection

*This is addressed by risk matrices that prescribe water-deflecting roof overhangs related to site conditions, provision of a roof that collects and diverts water at its edges with guttering, windows, and doors that shed water at heads and sills, good rebates and flashings being provided at all penetrations, and footings that raise the base of walls clear of splashing. Coatings may also exclude or limit the penetration of water. If roof overhangs are not wide enough to give adequate protection, then other rain deflection methods such as protective rain-screening claddings, or alternative rain-screening methods need to be employed. Lesser eaves widths combined with other weather protection measures such as external rain screening or cladding over a drained cavity, fences, pergolas, or other permanent landscaping features may be possible in some cases by using specific design, but these are outside the scope of this standard.*

#### Drying

*Damp-proof courses protect the bases of the walls from the risk of rising damp.*

*Wall surfaces are finished so that any moisture that reaches them either is shed or if absorbed by the walls will readily dry out again before it can cause damage. All surface coatings are required to have high levels of water vapour permeability. These measures help ensure that moisture, if it gets in from either the exterior or the interior, will not migrate deeply into the substrate and is not trapped within the wall but can get out again and the wall can remain dry.*

#### Drainage

*Site selection avoids flood plains, and site drainage diverts any overland paths for floods.*

*Walls, flashings and building details are designed and built so water is not trapped on or against any surfaces but can flow off and away.*

*Cavities, if used, are drained, and vented at the bottom so moisture cannot build up within them.*

#### Durability

*This ensures that materials and their surface coatings are durable enough to withstand what moisture is likely to reach them during the lifetime of the building.*

*Designing in a way that reduces the risk of high impact by wind-driven rain, backed by a range of durability tests on chosen materials, promotes durability.*

### 2.7.1 Requirement for minimum roof overhangs

Suitable protection from exterior moisture to all earth walls shall be provided by minimum roof overhangs that are either eaves, verges, or verandahs and sized according to the wind speed zone (Table 2.3) and the erodibility index of the wall material.

In wind speed speeds from low to very high as detailed in Table 2.2, protection from exterior moisture to all earth walls shall be provided by minimum roof overhang widths in accordance with Table 2.3 and Figures 2.5, 2.6, 2.7, and 2.8.

Roof overhang widths less than the minimum stated in Table 2.3 and Figures 2.5 to 2.8, or a building located in a wind speed zone that exceeds very high as per Table 2.2, are outside the scope of this standard.



To find the minimum erodibility indices that apply to the walls below the roof overhangs at or greater than these minimum roof overhangs widths, see the graphs in Figures 2.5 to 2.8. These requirements apply to all roof overhangs.

The measurement of roof overhang widths,  $w$ , and wall height,  $h$ , is shown in Figure 2.4. This figure also shows the protection slope angle, and these values are given on the graphs in Figures 2.5 to 2.8.

The height,  $h$ , is measured vertically between the highest point on the underside of the outer edge of the roof overhang to the lowest point of the earth wall.

The exposed wall height,  $h$ , shall include the height of any timber gable wall or stub wall that may be on top of a lower earth wall.

The ratio of wall height to roof overhang width is given by  $(h \div w)$ .

Gutters shall not be included as part of any roof overhang widths.

Including gutters as part of roof overhang widths, is outside the scope of this standard. Roof overhang widths are calculated using Table 2.3, in conjunction with Figures 2.5 to 2.8, which also gives the maximum slope of above horizontal of a line from the earth wall base to the outer edge of the roof overhang for each wind zone and each erodibility index value.

In high wind zones height to width ratios between 3.2:1 and 2:1 applies only to north-facing earth walls that are not stabilised with cement or lime, and such walls shall face within the northerly quadrant between north-east and north-west. See Table 2.3 and Figure 2.7 and C2.7.1.1.

In low or medium wind zones the minimum erodibility index figure for earth walls that are protected by permanent shelter may be reduced from  $EI=1$  to  $EI=2$ . At least two rows of permanent obstructions similar sized to the buildings are required for the site to be considered sheltered. Suitable weather protection as set out in 2.7 is required for all earth walls regardless of whether the walls are considered load bearing or non-load bearing.

### **C2.7.1**

*In the high wind zone, the improved moisture-penetration resistance properties of clay surfaces, which are free to swell to form a waterproof layer, are recognised. When these materials get wet they have superior resistance to moisture penetration compared to the more porous matrices formed by cement and lime stabilisers, especially when combined with the effect of the sun on the northern aspect in helping keep these walls dried out.*

#### **Examples**

*For roof overhangs in a low wind zone that are 2400 mm high above the base of an earth wall at their outer edge ( $h$ ), for walls with an erodibility index of 3, the roof overhang width ( $w$ ) from the graph in Figure 2.5 will need to be a minimum of 1200 mm.*

*In a high wind zone, with roof overhangs that are 1200 mm wide and 2200 mm high above the base of an earth wall. This is within the area where the erodibility index is 1, so an erodibility index of 1 will need to be specified, and this roof overhang width only applies to a north facing wall in accordance with 2.7.1. So this wall is not to be stabilised with cement or lime and is required to face between north-east and north-west.*

*The ratios in Table 2.3 provide minimum roof overhang widths and greater widths may be specified.*

*NZS 3604 provides for cantilevered roof overhangs of up to 750 mm or for verandah design. Roof overhangs that cannot be designed according to NZS 3604 will require specific engineering design.*

*The graphs in Figures 2.5 to 2.8 show the allowable roof overhangs widths for various wind exposures and erodibility indices ( $EI$ ) in accordance with 2.7 and Table 2.3. OS denotes outside the scope of the standards.*

*Weather protection may also be provided by rain screen cladding or other protective measures against the impact of wind driven rain but these are outside the scope of the standards.*

*The wind speed zone is used to establish the likely exposure of a wall to wind driven rain.*

*The erodibility index is a measure of the likely effect of wind driven rain on a wall by testing for surface erosion of material along with the depth of water penetration on representative samples of wall materials when exposed to a controlled water supply hitting the material over a period of time. It is used as a pre-construction prediction of performance of the wall in terms of its durability and resistance to external moisture when combined with proscribed roof overhangs.*

*Assessment and tests for  $EI$  are given in NZS4298 Appendices K and L.*

Applied surface coatings have not been proven to be very effective by themselves in limiting erosion or moisture penetration of earth walls so apart from 4298 8.2.3, 8.3.4 and K3.2 allowing some small increase in EI from surface coatings, the use of surface coatings or any reduction in roof overhang requirements remains OS the scope of the standards.

Table 2.3 – Maximum erodibility index for earth walls

| Wind zone | Maximum ratio of wall height ( $h$ ) to roof overhang width ( $w$ ) | Maximum slope angle above horizontal of line from wall base to roof overhang (see Figure 2.4) | Erodibility index                    |
|-----------|---|---|--------------------------------------|
| L         | 4 to 1  | 76°   | See Figure 2.5 for Erodibility index |
| M         | 8 to 3 (2.7 to 1)   | 69°   | See Figure 2.6 for Erodibility index |
| H*        | 3 to 2 (1.5 to 1) *See 2.7.1  | 56°   | See Figure 2.7 for Erodibility index |
| VH        | 1 to 1  | 45°   | See Figure 2.8 for Erodibility index |

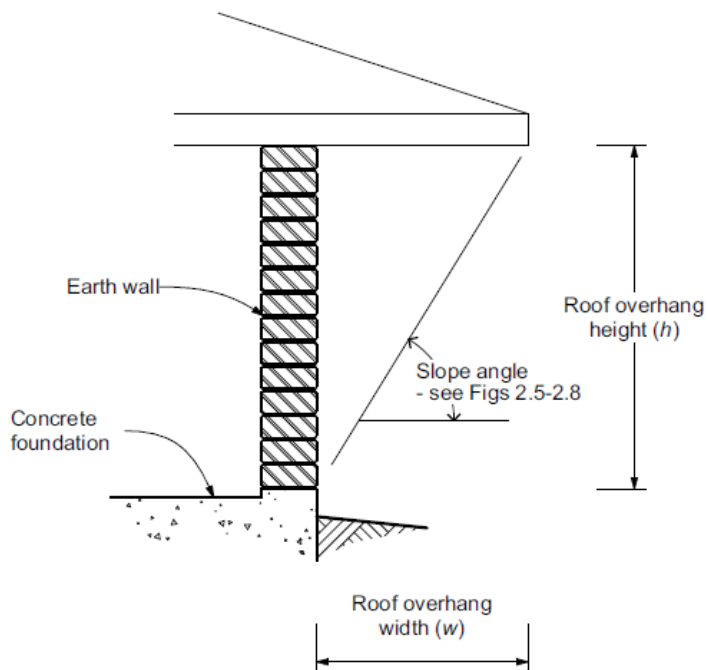

Figure 2.4 - Definition of roof overhang height and roof overhang width

Figure 2.4 – Definition of **roof overhang** height and **roof overhang** width

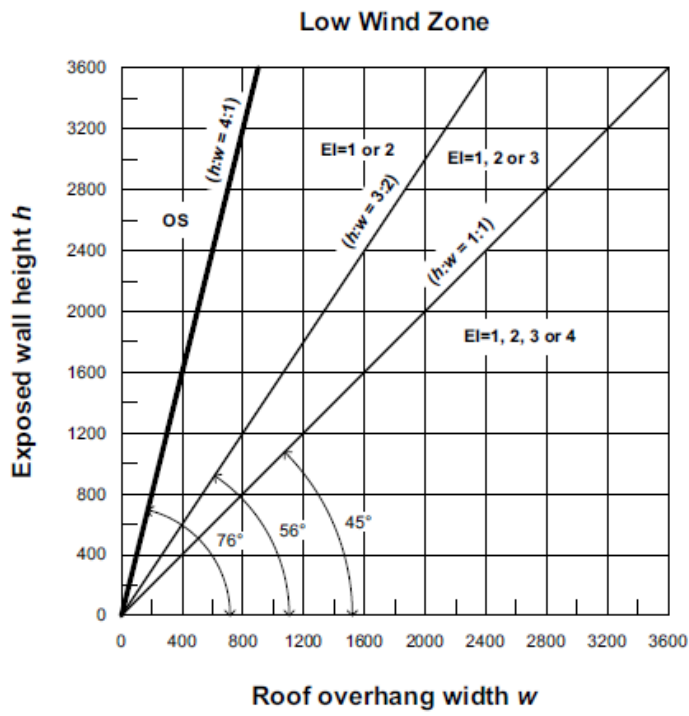

Figure 2.5 - Minimum roof overhang width for low wind zone 5

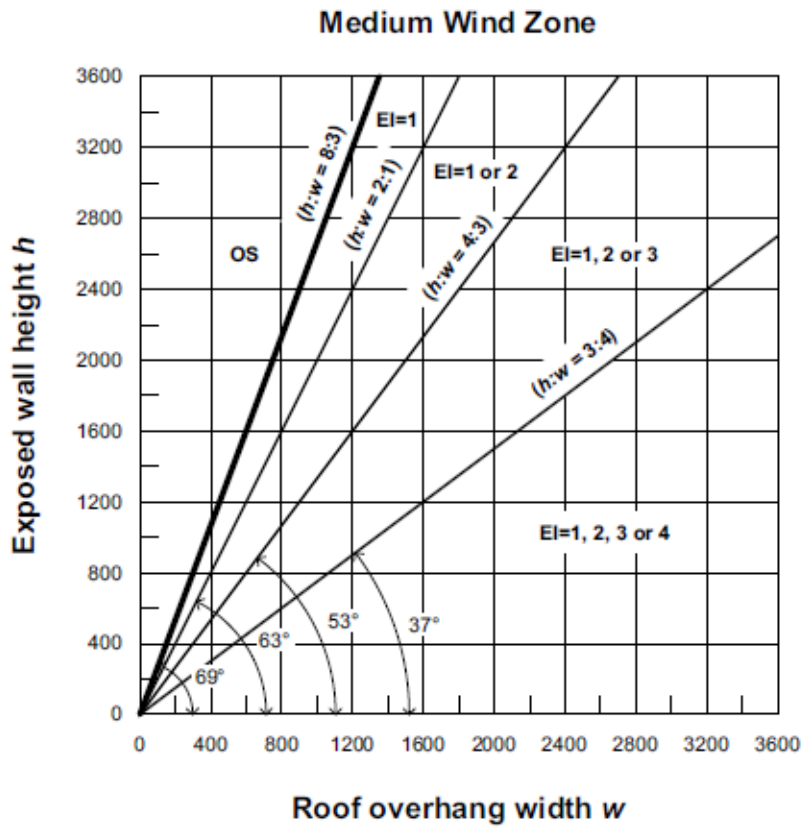
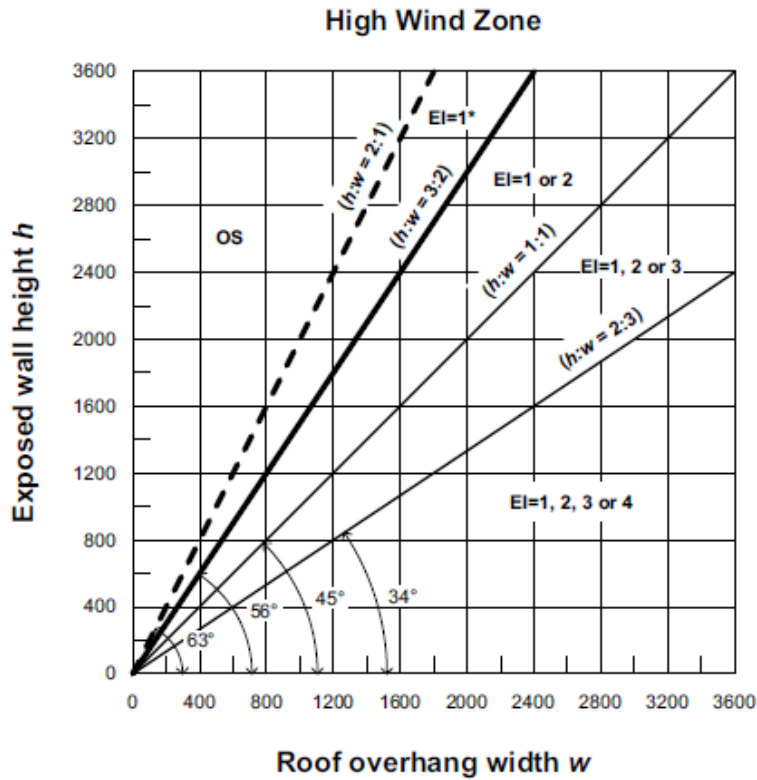

Figure 2.6 - Minimum roof overhang width for medium wind zone



\* See 2.7.1 Unstabilised earth in Northerly quadrant only

Figure 2.7 - Minimum roof overhang width for high wind zone

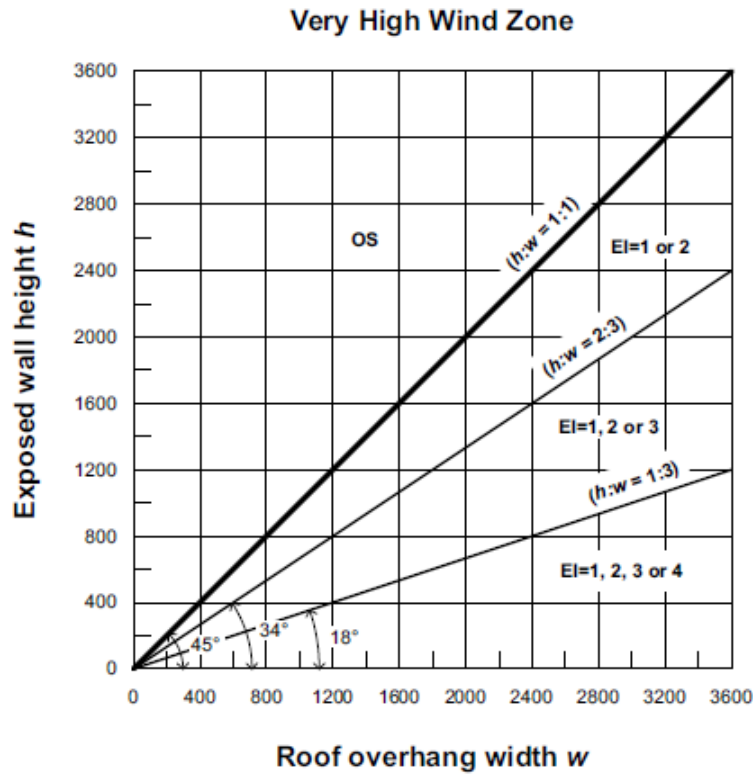

Figure 2.8 - Minimum roof overhang width for very high wind zone

Figure 2.8 - Minimum roof overhang width for very high wind zone

### 2.7.2 Reverse roof overhang

On any roof overhang that slopes upward to its outer edge, known as a reverse slope, the height of the roof overhang shall be taken at the underside of the outermost edge ( $h$ ) in Figure 2.4) at the highest point of that roof overhang measured at right angles to the wall in question.

#### C2.7.2

*Examples show the upper roof overhang of a mono-pitch roof. On a raking roof overhang the height of the roof overhang is taken at the highest point. The eave-to-wall junction shall be detailed as shown in Figure 6.9. Note that 2.7.1 also applies to reverse eaves where the inclusion of gutters as part of the roof overhang width is outside the scope of the standard.*

### 2.7.3 Individual assessment of adjoining earth walls for weather protection

If walls are being assessed individually for weather exposure, then wind-driven rain from each full quadrant onto each wall shall be considered and protection from diagonal rain from the more exposed quarter onto adjoining walls shall be given.

The minimum roof overhang to a wall adjacent to a more exposed wall will be 0.7 times the eaves required for the most exposed wall at any exterior wall intersection as shown in Figure 2.9. This may occur when a site is very exposed in one or two quadrants, yet the other faces of the building are relatively sheltered possibly by other buildings, land contour, or permanent dense bush cover, so the required roof overhang protection to each face may be determined separately.

#### C.2.7.3

*Allowing for diagonal rain from an exposed aspect may require a wider roof overhang than that required for rain coming from right angles onto a more sheltered wall. I.e.,  $0.7 W_e$  may be larger than  $W_s$  in some instances.*



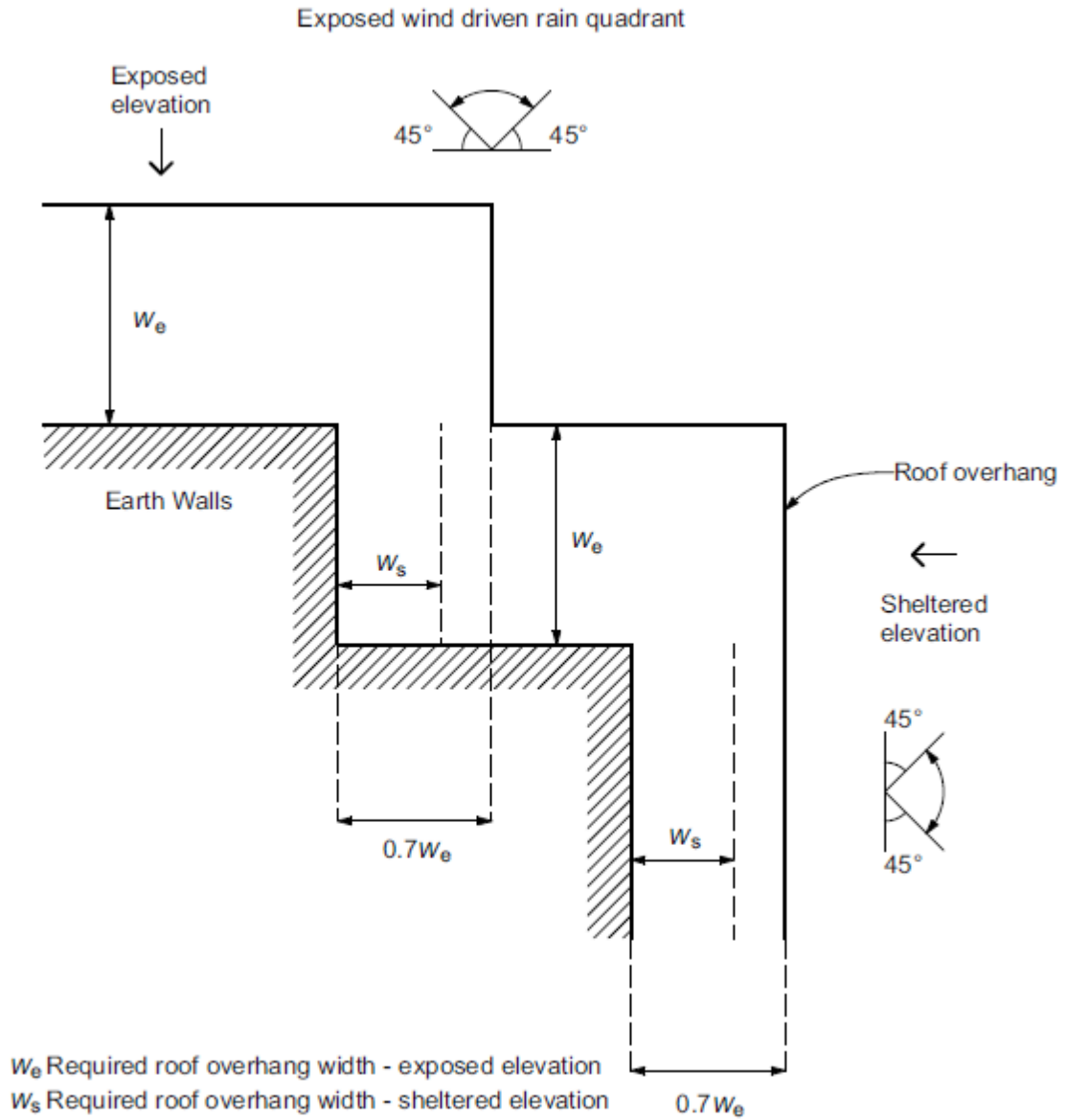

Figure 2.9 – Protection for sheltered walls – plan

## 2.8 Energy efficiency

### 2.8.1 Determining the R-value

The total thermal resistance  $R_T$  of an earth wall shall be determined in accordance with NZS 4214, with the thermal conductivity ( $k$ ) of the particular earth material to be used determined from the graph in [Figure 2.10](#).

The density of the earth material shall be determined from NZS 4298 Appendix M. 1 Buildings with walls that are a mixture of different earth densities shall be subject to SED.

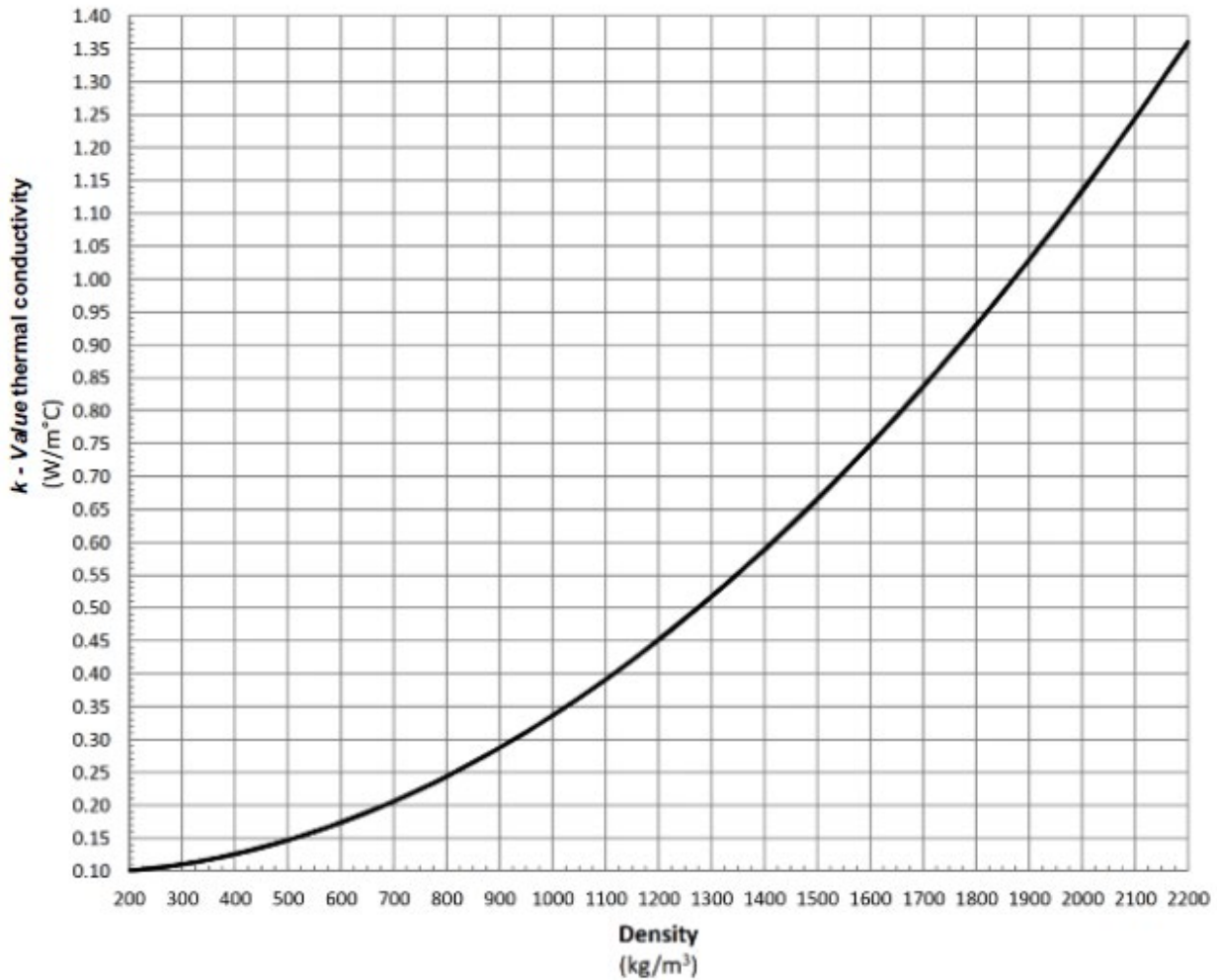

Figure 2.10 – Thermal conductivity values for earth walls

**C2.8.1**

The thermal resistance of an earth wall is dependent primarily on its density and thickness. The thermal resistances of its surfaces and any coverings, insulating layers, and air gaps also need to be considered.

The density to be used depends on the position of the wall and whether its primary function is insulation or heat storage/acoustic insulation.

Normal or heavy earth walls have a density from 1400 kg/m<sup>3</sup> to 2200 kg/m<sup>3</sup>.

Low-density earth walls have density from 800 kg/m<sup>3</sup> to 1400 kg/m<sup>3</sup>.

LEM walls have a density range between 200 kg/m<sup>3</sup> and 1200 kg/m<sup>3</sup>.

Densities below 350 kg/m<sup>3</sup> are possible to make but they can lack the strength to be able to withstand external face loads on a wall when direct plastered. If constructed using a lath or permanent or lost formwork to support the plaster these lower density materials may be used.

Enhanced insulation above the minimum requirements of the New Zealand Building Code may give enhanced energy efficiency by reducing heating loads.

The k-values given in Figure 2.10 are derived from static-state measurements. However, a variety of different factors affect the thermal performance of an earth wall in a real-world dynamic situation, including its orientation, its exposure to direct sun, its surface colour, and its climatic region.

Earth walls are well known for often giving better thermal performance than their static R-values would suggest, especially when coupled with passive solar design, and therefore it is anticipated that most earth buildings will need to have their thermal performance calculated or modelled for more complex buildings using a modelling method that allows for thermal mass effects and a wide range of building configuration and climatic factors.

**Worked example - Establishing the R-value of an earth wall**

From NZS 4214 the R-value will be given by

$$R = \frac{t_w}{k}$$

where:

k is the thermal conductivity of the earth wall from the graph in Figure 2.10 for the density of the particular material.

t<sub>w</sub> is the wall thickness in metres.

Add the interior and exterior surface thermal resistance R<sub>si</sub> + R<sub>se</sub> as given by NZS 4214:

$$R_{si} = 0.09 \text{ m}^2 \text{ }^\circ\text{C/W}$$

$$R_{se} = 0.03 \text{ m}^2 \text{ }^\circ\text{C/W}$$

The total thermal resistance R<sub>T</sub> value is the sum:

$$R_T = R_{si} + R + R_{se}$$

A wall with a density of 1600kg/m<sup>3</sup> will have a k value of 0.75 from Figure 2.10 and if it is 430 mm thick, its R-value will be 0.43/0.75 or 0.57 m<sup>2</sup> °C/W

Then add on the interior and exterior surface thermal resistance (0.09 + 0.03) m<sup>2</sup> °C/W to give a total R-value for this 430mm thick wall of 0.57 + 0.12 = 0.69 m<sup>2</sup> °C/W

Where other insulating layers are present these are also taken account of by the methods given in NZS 4214.

### 2.8.2 Insulation of earth walls

Externally insulated earth walls are outside the scope of this standard, apart from internal adobe veneer walls in Appendix F.

Internal insulation of earth walls prevents any benefit being obtained from thermal mass or the hygroscopic nature of earth being obtained and is not recommended.

#### C2.8.2

*Designers who wish to externally insulate earth walls are advised to consider the following factors:*

- *Method of attachment of any insulation and cladding*
- *Ensure the permeance of the external surface of the earth wall behind the insulation and cladding as required in 4298 section 8 - Surface Coatings is maintained. Note that there have been reports of moisture build up and damage if impermeable or sheet insulation materials are directly attached to the exterior of earth walls, even if the walls had fully dried out.*
- *Potential dew point formation within external insulation.*
- *Details around openings and penetrations need to keep external moisture away from the supporting earth walls behind the insulation and cladding.*

## 2.9 Internal moisture

### 2.9.1 Internal moisture control

Airborne internal moisture shall be controlled by:

- Providing ventilation which meets the requirements of Acceptable Solution G4/AS1; and
- Ensuring that earth walls meet the requirements of 2.9.1.1 and 2.9.1.2, to ensure that their vapour permeability is not compromised by interior or exterior surface coatings or by any materials or finishes applied to or laid over the wall face.

#### 2.9.1.1 Exterior wall surface permeability requirements

Earth walls shall not be over-clad or overlaid with another cladding system or exterior surface material that reduces the permeability of the wall, other than a surface coating that meets the requirements of NZS 4298 section 8.

Exterior surface coatings shall meet the permeability requirements of NZS 4298 clause 8.5.4.

#### 2.9.1.2 Interior wall surface permeability requirements

Earthen interior wall surfaces may be left uncoated unless they are within splash zones. Splash zones are surfaces adjacent to sanitary fixtures and sanitary appliances, and other surfaces likely to be splashed or become contaminated in the course of the intended use of the building.

Any coatings applied to earth walls beyond any splash zones shall meet the permeability requirements of 8.5.4. This includes wall surfaces of service rooms such as kitchens, bathrooms, toilets, and laundries, where those surfaces are not adjacent to sanitary fixtures and sanitary appliances and are not likely to be splashed or become contaminated in the course of the intended use of the building.

### 2.9.2 Accidental overflow

Earth floors shall not be used in areas of a building where accidental overflow from a sanitary fixture or sanitary appliance could damage an adjoining household unit or other property.

**C2.9.2**

*Earth floors are unsuitable for providing containment of any overflowing water from sanitary fixtures or sanitary appliances.*

*Earth floors are therefore unsuitable for inclusion in Acceptable Solution E3/AS1 paragraph 2.0, which allows the use of containment and a floor drain in spaces where accidental overflow from a sanitary fixture could damage an adjoining household unit or other property. Within multi-unit dwellings, spaces such as kitchens, bathrooms, toilets, and laundries may therefore be unsuitable for earth floors.*

*Within standalone housing, an earth floor would also be at risk of damage if within a space where an accidental overflow could occur that could not be readily seen and mopped up.*

**2.9.3 Watersplash****2.9.3.1 Splash zones on earth walls**

For splash zones (as described in 2.9.1.2) on earth walls:

- (a) Within splash zones other than splash zones within showers, including within 500 mm of urinals and 200 mm up from bath rims, earthen wall surfaces shall be protected by an impervious and easy to clean overlay surface as listed in NZBC E3/AS1. The overlay surface in this instance shall be installed over fibre-cement board a minimum 6 mm thick screwed directly to the earth walls with countersunk galvanised screws a minimum 10g, penetrating the earth walls a minimum 100 mm, at 200 mm centres around the perimeter and 400 mm centres otherwise, or in the case of sealed timber linings be installed over battens as noted in (b) below.
- (b) Within showers (including showers over baths), earthen wall surfaces shall be protected by an impervious and easy to clean overlay surface listed in NZBC E3/AS1 for within showers over fibre-cement board, a minimum 6 mm thick, screwed to battens (minimum 40 mm x 20 mm H3.1 or equivalent durability) spaced at 400 mm centres, screwed directly to the earth walls with countersunk galvanised screws minimum 10g, penetrating the earth walls a minimum 100 mm at 200 mm centres. The junctions between substrate sheets and at corners including at the floor to be waterproofed with suitable waterproofing membrane and reinforcing under the impervious lining as described in NZBC E3/AS1 and as per NZS 4298:8.12.
- (c) Impervious and easy to clean surface coatings for earth walls in splash zones and junctions to adjacent sanitary fittings or earth walls shall meet the requirements of NZS 4298 clause 8.11.

**C2.9.3.1**

*Examples of acceptable impervious and easy to clean linings and finishes for walls within splash zones other than within showers and near urinals are given in Paragraph 3.1.2 of Acceptable Solution E3/AS1. Examples of acceptable impervious and easy to clean linings and finishes for walls within showers are given in Paragraph 3.3.1.2 of Acceptable Solution E3/AS1. However, E3/AS1 does not provide junction and installation details suitable for earth walls.*

**2.9.3.2 Splash zones on earth floors.**

Splash zones on earth floors shall meet the requirements of 12.4.7.

### 3 SITE REQUIREMENTS

#### 3.1 Soil-bearing capacity

##### 3.1.1 Good ground

The site requirements of this standard are concerned with soil conditions under or adjacent to the building.

Sites that are excluded from being good ground are:

- (a) Soils that are designated as expansive soils where they have:
  - (i) A liquid limit of more than 50% when tested in accordance with NZS 4402, Test 2.2, and
  - (ii) A linear shrinkage of more than 15% when tested in accordance with NZS 4402, Test 2.6;
- (b) Any ground that could foreseeably experience movement of 25 mm or greater for any reason including one or a combination of: land instability, ground creep, subsidence, liquefaction, lateral spread, seasonal swelling and shrinkage, frost heave, changing groundwater level, erosion, dissolution of soil in water, and effects of tree roots.

If a site does not comply with the requirements for good ground set out in 3.1.3 the foundations shall be the subject of SED and investigation.

##### **C3.1.1**

*Foundations for houses built on ground that has the potential for liquefaction or lateral spread are outside the scope of this standard.*

*The EQC/MBIE/MfE guidance document 'Planning and engineering guidance for potentially liquefaction-prone land' outlines a risk-based process to identify and manage liquefaction-related risk in land use planning and development decision-making. Advice on liquefaction risk may be able to be sourced from a territorial local authority.*

*For houses built in areas that have the potential for liquefaction, the MBIE guidance document 'Repairing and rebuilding houses affected by the Canterbury earthquakes' may be appropriate. This guidance provides a range of potential foundation solutions depending on expected ground movement and available bearing capacity. These parameters also determine the required degree of involvement of structural and geotechnical engineers and the extent of SED.*

##### 3.1.2 Foundations

The foundation provisions of this standard shall apply only for level building sites such that:

- (a) The foundations for the building are supported on good ground with an ultimate bearing capacity of 300 kPa. Determining good ground shall be as given in 3.1.3;
- (b) Any foundation for a building erected at the [bottom of a slope shall be formed in accordance with Figure 3.1 \(A\)](#); and
- (c) [Any foundation for a building erected at the top of a bank shall be 0.6 m behind the ground line shown in Figure 3.1 \(B\)](#);
- (d) The horizontal distance,  $H$ , from the top to the bottom shall not exceed 3.0 m. The maximum height of the bank,  $V$ , and the minimum width of ground,  $L$ , with a slope of less than  $5^\circ$  beyond the bank shall be such that in:
  - (i) Rock  $H/V > 1$ ;  $L/V > 2$
  - (ii) Clay or sandy clay  $H/V > 2$ ;  $L/V > 3$
  - (iii) Other materials  $H/V > 3$ ;  $L/V > 4$ ;
- (e) The slope beyond the bank,  $L$ , shall not exceed  $5^\circ$  for a distance of 10 m;
- (f) Fill, including hardfill placed over undisturbed ground or certified fill, shall not exceed 0.6 m in depth above natural ground level if within 3.0 m of a foundation.

**C3.1.2**

- (a) This is to confirm that the provisions of the Building Act section 71 (Building on land subject to natural hazards) have been addressed within the context of this standard.
- (b) These provisions are to guard against erosion or frittering of soil that exposes the foundation on minor banks, and to avoid localised slip failures that threaten the foundation. Stability of the site as a whole is covered by 3.1.3(g).
- (c) This limitation is required, as moderate depths of earth fill spread over a large area adjacent to the building foundations can cause weak layers of underlying soil to consolidate within a depth of influence of approximately twice the width of the fill. Such consolidation can cause differential settlement of the building foundations and thus cause damage to the building. Typically, earth fill placed adjacent to foundations for the construction of stairs, terraces, landscaping, and built-up ground under concrete floor slabs can cause such settlements.

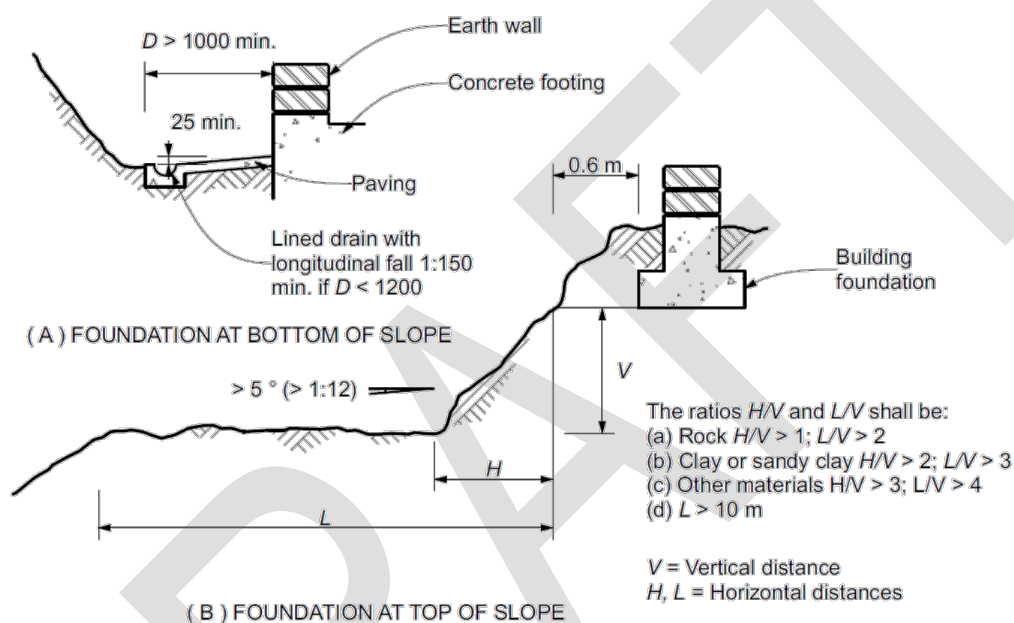

**Figure 3.1 – Relationship of foundation to nearby sloping ground surface**

**3.1.3 Determining good ground**

The soil supporting the footings shall be assumed to be good ground when all the following conditions (a) to (d) are met:

- (a) Reasonable inquiry through the project information memorandum (PIM) and site observation shows no evidence of buried services and none is revealed by excavation for footings;
- (b) Reasonable inquiry through the PIM and site observation shows no indication or record of land slips or surface creep having occurred in the immediate locality;

**C3.1.3(b)**

Surface creep is often evident by trees that have leaned over due to surface creep and then continued to grow vertically. Surface creep is also observed by leaning retaining walls. Land slips are often made evident by saucer depressions in the landscape.

- (c) Reasonable inquiry shows no evidence of earth fill on the building site, and/or no fill material is revealed by the excavation for footings. This shall not apply where a certificate of suitability of earth fills for residential development has been issued in accordance with NZS 4431 for the building site, and any special limitations noted on that certificate are complied with; and
- (d) Excavation for footings does not reveal buried organic topsoil, soft peat, very soft clay, soft clay, or expansive clay (see 3.2.1 and 3.3.8).

And any of the following (e) to (g) are met:

- (e) Where indicated by specific site investigation, using the test method for soil-bearing capacity contained in 3.3;
- (f) Where inspection of existing structures on this or neighbouring sites and reasonable enquiry, including territorial authority records, local history of the site, and published geological data such as structural geology where appropriate, shows no evidence of erosion (including coastal erosion, bank erosion, and sheet erosion), surface creep, land slippage, or other falling debris (including soil, rock, snow, and ice), uncertified fill, fill over original water course, or subsidence having occurred in the immediate locality;
- (g) When geotechnical completion reports in accordance with NZS 4404 identify subsoil class and areas that provide good ground.

### **C3.1.3(g)**

*Geotechnical completion reports generally list the ultimate bearing capacity of the ground of each lot, presence of expansive clay, topsoil depths, any presence of uncertified fill requiring specific site investigation, and stability problems that may define area limits of any building platform.*

*Project information memorandum (PIM) records might not include geotechnical information from subdivision reports confirming good ground on a site. Geotechnical reports need to be examined separately. Good ground is required for stability and control of settlement of foundations and can most reliably be verified by subsoil investigation, but an appropriate assessment should include the bigger picture.*

*NZS 4404 requires geotechnical completion reports to identify site subsoil class, areas that provide good ground, and those areas that require SED.*

*Tests in accordance with 3.3 below offer a comparatively simple method for establishing whether or not an ultimate bearing capacity of 300 kPa may be assumed.*

## **3.2 Soil types**

### **3.2.1**

Soil description shall follow the recommendations in the New Zealand Geotechnical Society (NZGS) report, 'Field description of soil and rock – Guideline for the field classification and description of soil and rock for engineering purposes.'

These descriptions are as follows:

- (a) Organic soils include topsoil, organic clay, silt, sand, or peat;
- (b) Very soft cohesive soil easily exudes between fingers when squeezed;
- (c) Soft cohesive soil is easily indented by finger pressure;
- (d) Firm cohesive soil can be indented by strong finger pressure, or by thumb pressure;
- (e) Very loose and loose non-cohesive granular materials when penetrometer readings are fewer than three blows per 100 mm; and
- (f) Fill material, except where a certificate of suitability has been issued under NZS 4431.

### **3.2.2**

For the purpose of 3.1.3(d), clays shall be treated as expansive clays if their soil properties in soil mechanics terms exceed the values listed in the definition of good ground (see 3.1).

## **3.3 Test method for soil bearing**

### **3.3.1**

#### ***Purpose***

Where the requirements of 3.1.3 have not been met, the Scala Penetrometer test method may be used to establish that the soil supporting the foundations can be assumed to have an ultimate bearing capacity of not less than 300 kPa as required by 3.1.2(a).

### **3.3.2**

#### ***Scala Penetrometer test***

The apparatus shall consist of a dynamic cone penetrometer conforming to the dimensions and masses given in Test 6.5.2 of NZS 4402 (imperial versions of this equipment were commonly referred to as the Scala Penetrometer). This shall be used for coarse-grained, non-cohesive soils (sands or coarser) or fine-grained (silt size or less) and cohesive soils using:



- (a) A scale or measuring rod graduated in 50 mm intervals to an accuracy of 1 mm;
- (b) A sight board or other suitable datum.

**C3.3.2**

*The Scala Penetrometer provides a method to establish if good ground is present. The Scala Penetrometer provides a quantitative method of determining the soil profile and the relative strength of each layer.*

**3.3.3 Testing**

The dynamic penetrometer test method shall be used as described in NZS 4402, Test 6.5.2; either Procedure 1 or 2.

**3.3.4 Depth**

The tip of the penetrometer shall be driven to a depth below the underside of the proposed footing or pile of not less than 2.0 m for strip or pile footings as specified in section 5 unless rock is encountered.

**3.3.5 Test method**

The penetrometer need not be removed during driving. As an alternative to driving, the penetrometer may be used within a probe, or a hole augered for the purpose of penetrometer testing, provided that no account shall be taken of any blow made when the bottom of the probe hole is less than 300 mm above the tip of the penetrometer.

**3.3.6 Borehole log**

A borehole of not less than 50 mm in diameter shall be augered at the site (sufficient to prove ground consistency) of each penetrometer test, according to the depths in 3.3.4 (unless rock is encountered). For each borehole a soil description log in accordance with the NZGS report 'Field description of soil and rock – Guideline for the field classification and description of soil and rock for engineering purposes' shall be recorded for each 300 mm or part thereof below the ground surface, stating whether this is original ground level or cleared ground level as appropriate. The log should also include a continuous record of the number of blows per 100 mm, water table level if observed, and the location and level of each borehole and dynamic penetrometer test should be marked on the site plan.

**3.3.7 Ultimate bearing capacity**

The soil below the underside of the foundations shall be assumed to have an ultimate bearing capacity of not less than 300 kPa when:

- (a) None of the following is encountered below the depth of the footing at any test site:
  - (i) Organic topsoil
  - (ii) Soft or very soft peat
  - (iii) Soft or very soft clay
  - (iv) Fill material, except where a certificate of suitability has been issued under NZS 4431;
- (b) Scala Penetrometer tests conducted in accordance with 3.3.2(a), where the number of blows per 100 mm depth of penetration below the underside of the proposed footing at each test site exceeds:
  - (i) Five down to a depth equal to twice the width of the widest footing below the underside of the proposed footing
  - (ii) Three at greater depths, and
  - (iii) Providing the set per blow is relatively uniform, the number of blows per 100 mm may be obtained by averaging the number of blows for depths not exceeding 300 mm; and
- (c) Comparisons of the results at all test sites show that soil conditions are closely similar at each test site.

**C3.3.7(a)**

*Scala Penetrometer results can be subject to climatic conditions, where soils are exposed to excessive drying. The set for each blow should be similar to previous sets. Large sets per blow followed by smaller sets per blow could be due to stony ground. In this case the average reading over 100 mm may give the wrong information.*

*Very loose and loose non-cohesive soils can settle in earthquakes resulting in damaged foundations.*

### 3.3.8 *Test sites*

Test sites shall be selected to give adequate information about the soil over the entire plan area of the proposed building, provided that there shall be a minimum of four test sites for a building up to 200 m<sup>2</sup> plan area, with at least one additional test site for each 100 m<sup>2</sup> additional plan area of the building.

### 3.3.9 *Test record*

The position and level of each test site in relation to proposed foundations shall be recorded.

## 3.4 Bearing

### 3.4.1

All foundations shall bear on solid bottom in undisturbed good ground material or on firm fill for which a certificate of suitability has been issued under NZS 4431 (see 3.1.3(c)).

Where good ground is at a depth greater than 0.6 m, the excavation between the good ground and the foundation base may be filled with certified fill or mass concrete having a minimum strength of 10 MPa at 28 days.

### 3.4.2

The minimum depth of footings below the cleared ground level shall be 200 mm, 150 mm in firm weathered rock, or 100 mm in rock.

#### **C3.4.2**

*The depth of the foundation below ground level is not to be confused with the thickness of the footing. 'Cleared ground level' is used as the depth datum because this level is not usually altered by future landscaping, thus retaining the lateral support of the building.*

## 3.5 Site

### 3.5.1 *Site preparation*

Before a building is erected on any site, all rubbish and all noxious and organic matter shall be removed from the area to be covered by the building.

Sensitive clay soils can be subject to significant volumetric change with seasonal changes in moisture content. This can lead to post-construction damage to concrete floors particularly when construction is carried out in drought conditions. Exposed soils at the building site that exhibit cracking should be thoroughly wet prior to the commencement of construction works.

### 3.5.2 *Effects of tree roots on foundations*

Tree roots shall be considered as required in the definition of good ground in 3.1.1.

#### **C3.5.2**

*Trees remove moisture from the soil for a radius up to the height of the tree. This causes expansive soils to shrink to varying degrees, and when near houses leads to differential settlement occurring under foundations. The mature height of the tree is to be considered in the location of trees near houses. Movement of the foundations may lead to cracks in the building and door jamming.*

## 4 BRACING DEMAND

### 4.1 General

#### 4.1.1

Earth walls shall be constructed to resist the greater bracing demand imposed on the building by earthquake actions calculated as described in 4.2 and wind actions calculated as described in 4.3.

#### **C4.1.1**

*For earth buildings within the scope of this standard, the requirements for walls to be able to resist wind loads in most cases will be met or exceeded by the provisions to resist earthquake loads.*

#### 4.1.2

The construction requirements of bracing structures and their bracing capacity to resist the bracing demand are contained in section 6.

### 4.2 Earthquake demand

#### 4.2.1 Site subsoil classification

The site subsoil, classified in accordance with NZS 1170.5 and NZS 1170.5 commentary, shall be that advised by the territorial authority recorded in geotechnical completion reports under NZS 4404. If this information is not available, then the site subsoil classification shall be taken as class D unless SED is conducted.

#### **C4.2.1**

*The amplification of the surface shaking above the underlying rock subjected to earthquake motions is dependent on the depth and flexibility of the intervening soil/s.*

*Site subsoil classifications in accordance with 4.2.1 are:*

- (a) Class A – Strong rock;*
- (b) Class B – Rock;*
- (c) Class C – Shallow soil sites;*
- (d) Class D – Deep or soft sites; or*
- (e) Class E – Very soft soil sites.*

*Site subsoil classifications are often held by territorial authorities as part of their natural hazard records as required by section 35 of the Resource Management Act.*

*Site subsoil classification enables the calculation of earthquake bracing demand in buildings on different types and depths of soils over rock. The earthquake forces in buildings on class D and class E sites can be 65% greater than on rock sites.*

*Site classifications determined by SED require geotechnical investigation or specialist knowledge. Such determinations are outside the scope of this standard and need to be checked by the building consent authority as part of the building consent process.*

*Table 3.2 of NZS 1170.5 sets out the maximum depth limits, soil types, and strengths for site subsoil class C. Once the soil types and depths are known, a judgement can be made on site subsoil class for the level of bracing demand appropriate to the site.*

#### 4.2.2 Earthquake zones

The zoning in Figure 4.1 and Figure 4.2 shall be used in determining the bracing demands for buildings located in different regions of New Zealand.

Table 4.1 sets out the earthquake zones for principal localities in New Zealand. Earth buildings in zone 4 shall be subject to SED.

Table 4.1 – Earthquake zones

| Locality            | Earthquake zone | Locality            | Earthquake zone |
|---------------------|-----------------|---------------------|-----------------|
| <b>North Island</b> |                 | New Plymouth        | 1               |
| Kaitia              | 1               | Whanganui           | 2               |
| Whangarei           | 1               | Palmerston North    | 3               |
| Dargaville          | 1               | Dannevirke          | 3               |
| Helensville         | 1               | Wellington          | 3               |
| Auckland            | 1               |                     |                 |
| Thames              | 1               | <b>South Island</b> |                 |
| Paeroa              | 1               | Nelson              | 2               |
| Coromandel          | 1               | Blenheim            | 3               |
| Whitianga           | 1               | Christchurch        | 2               |
| Hamilton            | 1               | Lyttleton           | 2               |
| Waihi               | 1               | Timaru              | 1               |
| Tauranga            | 1               | Oamaru              | 1               |
| Rotorua             | 2               | Westport            | 3               |
| Taumaranui          | 2               | Greymouth           | 3               |
| Taupo               | 2               | Hokitika            | 3               |
| Gisborne            | 3               | Dunedin             | 1               |
| Napier              | 3               | Invercargill        | 1               |
| Hastings            | 3               | Alexandra           | 2               |

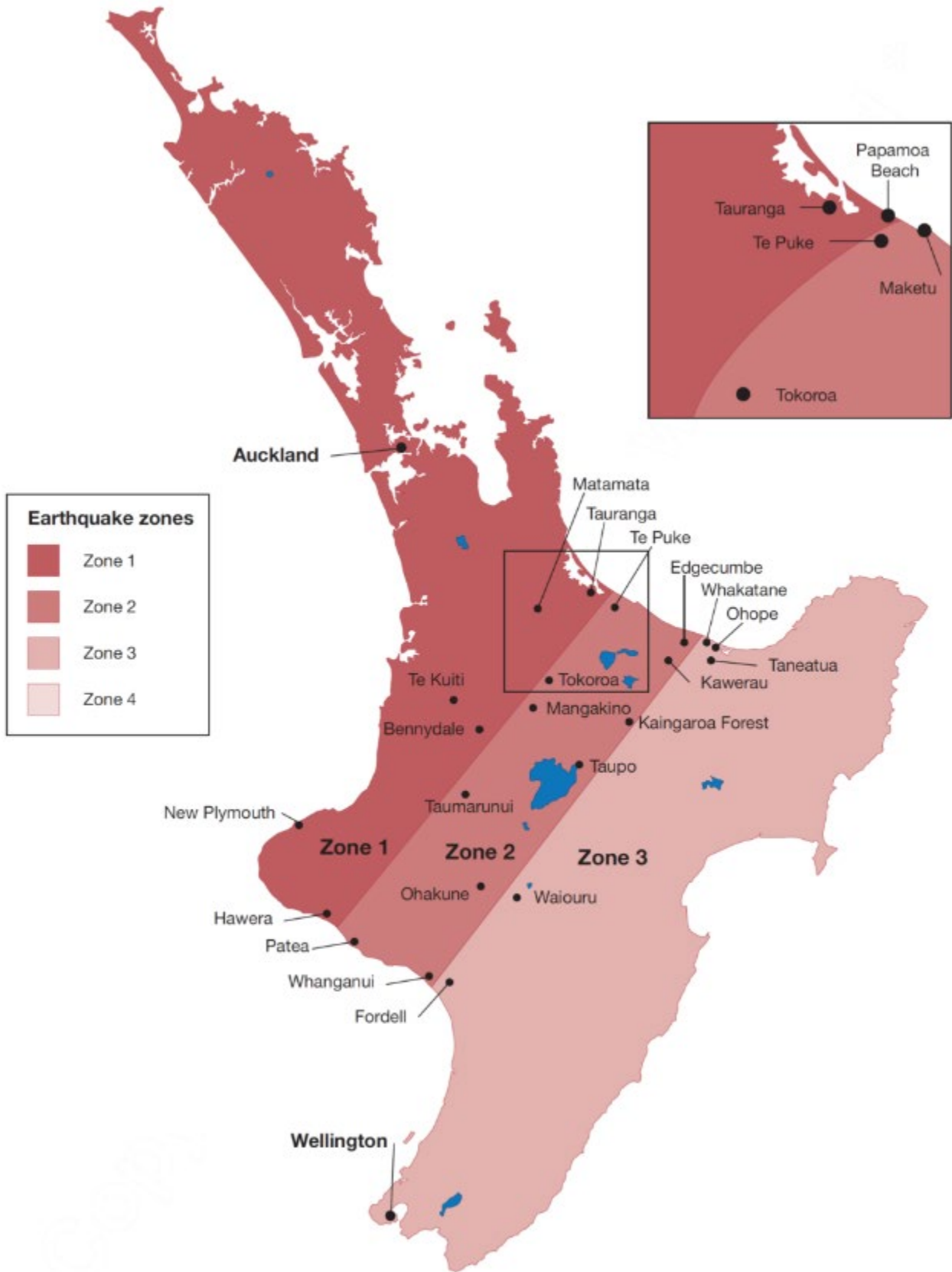

Figure 4.1 – Earthquake zones (North Island) (see 4.2.2)

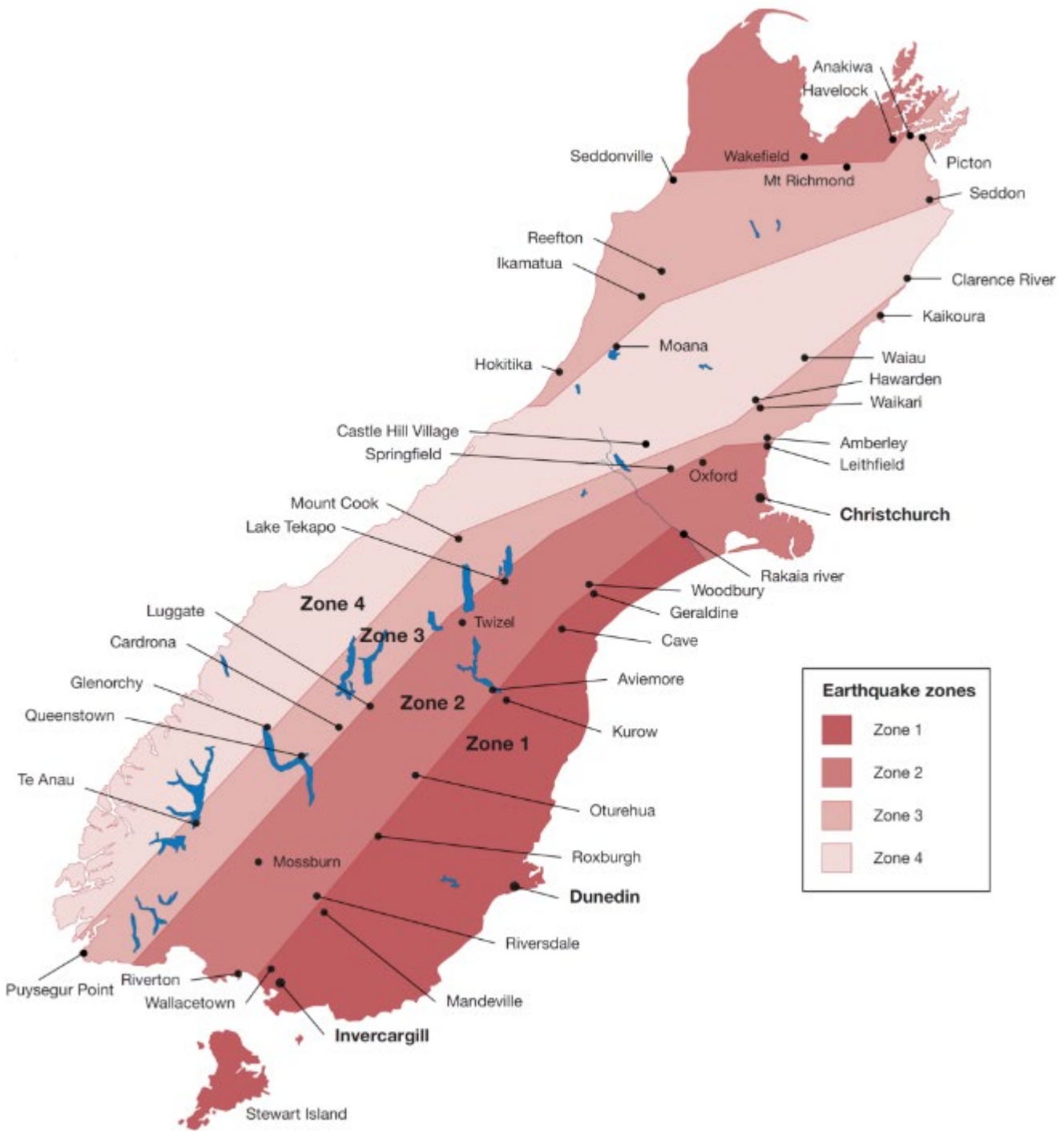

Figure 4.2 – Earthquake zones (South and Stewart Islands) (see 4.2.2)

### 4.2.3 Site earthquake factor

The site earthquake factor is determined from Table 4.2 using the site subsoil classification from 4.2.1 and the earthquake zone from 4.2.2.

**Table 4.2 – Site earthquake factor**

| Site subsoil class | Site earthquake factor, $K_e$ |      |      |
|--------------------|-------------------------------|------|------|
|                    | Earthquake zone               |      |      |
|                    | 1                             | 2    | 3    |
| A and B            | 0.30                          | 0.45 | 0.69 |
| C                  | 0.37                          | 0.56 | 0.86 |
| D and E            | 0.47                          | 0.71 | 1.09 |

### 4.2.4 Earthquake bracing demand

The seismic bracing demand for the whole building shall be determined from the site earthquake factor, building area and dimensions, wall density, wall dimensions and roof dimensions as given by the following steps:

- Measure the density of earth wall material using NZS 4298, Appendix M =  $\rho$  (kg/m<sup>3</sup>);
- Determine the volume in cubic metres of the earth walls above mid-height of the individual walls from the floor plan and elevations of the building =  $V_b$  (m<sup>3</sup>);
- Calculate the weight of the earth walls above mid-height of the individual walls,  $W_b = V_b \times \rho$  (kg);
- Determine the area of light roof of the building (including eaves and half the verandah area) from the roof plan =  $A_r$  (m<sup>2</sup>);
- Calculate the weight of the roof,  $W_r = A_r \times 45$  (kg);
- Determine the area of internal timber partition walls above mid-height (from the floor plan) =  $A_{iw}$  (m<sup>2</sup>);
- Calculate the weight of internal timber partitions,  $W_{iw} = A_{iw} \times 30$  (kg);
- Calculate the total seismic weight of the building,  $W_s = W_b + W_r + W_{iw}$  (kg);
- Calculate the earthquake bracing demand,  $B_{ue} = K_e \times W_s \times 0.2$  (BU = bracing units);

#### C4.2.4(j)

The factor 0.2 results from 1 kg = 0.2 BU or 1 kN = 20 BU.

- Determine the gross floor plan building area to the outside of the exterior walls,  $A_b$  (m<sup>2</sup>);
- Calculate the earthquake bracing demand per square metre  $B_{m2} = B_{ue} \div A_b$  (BU/m<sup>2</sup>).

### 4.3 Calculation of wind bracing demand

The wind bracing demand for the earth building shall be determined using the procedure in NZS 3604 clause 5.2 to determine the wind bracing per metre of building plan dimension in each direction and the total wind bracing demand.

### 4.4 Calculation of design bracing demand

The design bracing demand for each direction in the building is the greater of either the earthquake bracing demand from 4.2.4 or the wind bracing demand from 4.3 for that direction.

These design bracing demands are used in 6.3 to design walls to provide bracing capacity.

Buildings with bracing walls that are a mixture of different earth densities shall be subject to SED.

## 5 FOOTINGS AND CONCRETE SLAB ON GROUND

### 5.1 General

#### 5.1.1

Every earth wall, whether loadbearing or non-loadbearing, shall be supported by a continuously reinforced concrete footing of the dimensions and reinforcement given in this section. Footings shall be continuous under doorways and other openings.

#### 5.1.2

The footing shall be formed symmetrically about the centre line of the wall except where insulation is used between foundation wall and slab (see Figure 5.3 to Figure 5.12).

#### C5.1.2

*If 5.1.2 cannot be satisfied because a wall is to be built up to a boundary or for any other reason, then it will be necessary for both the footing and the wall to be the subject of SED. Such design is outside the scope of this standard.*

#### 5.1.3

Footings shall bear on a solid surface in undisturbed good ground. The footing shall have all bearing surfaces horizontal, but may be stepped in accordance with Figure 5.1 to accommodate variations in cleared ground level on sloping sites, or depth of formation level required to meet the ground bearing requirements of section 3.

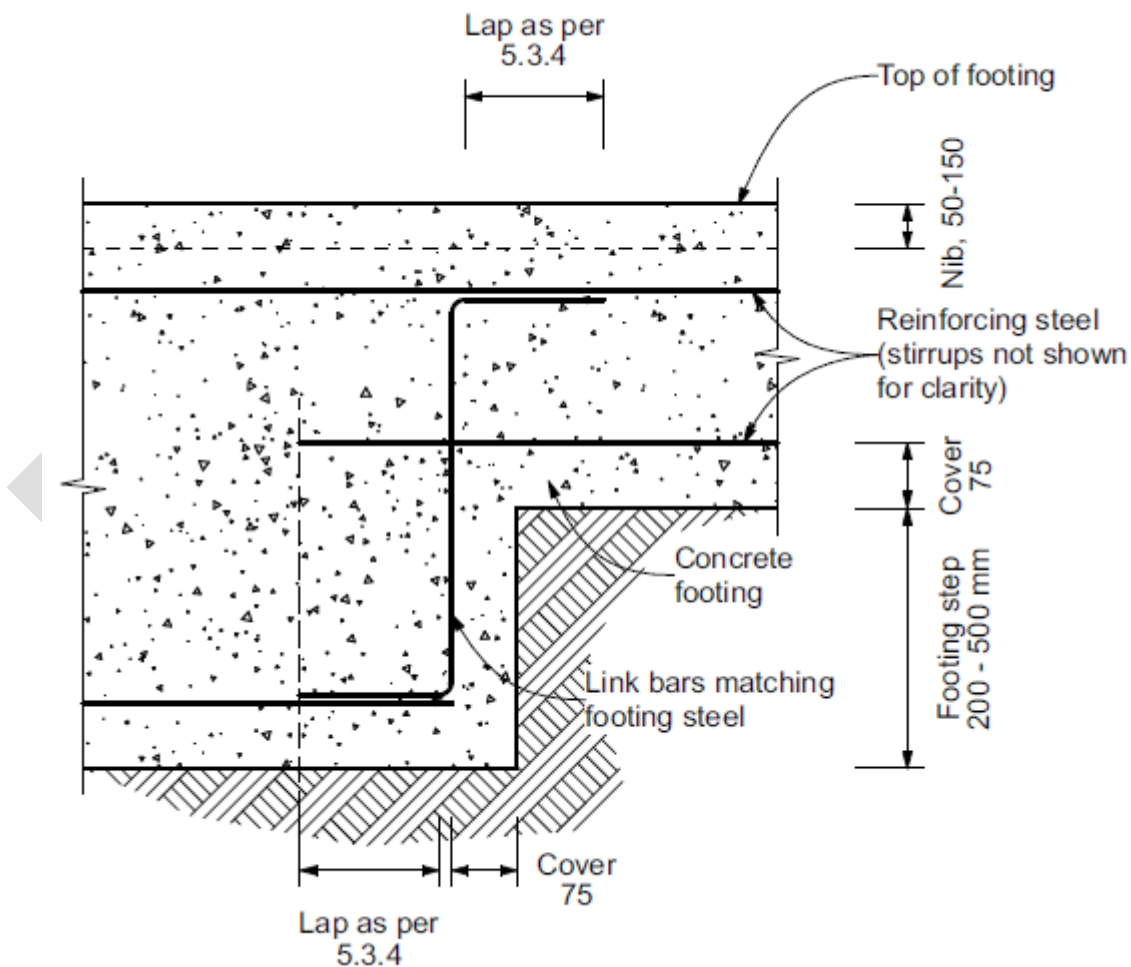

Figure 5.1 – Foundation details at footing step



## 5.2 Footings

### 5.2.1 Width of the footing

The width shall be not less than 280 mm or the width of the earth wall construction whichever is the greater.

### 5.2.2 Depth of footing

The footing shall extend to at least the depths below cleared ground level defined in 3.4 and be on soil with a bearing capacity as defined in firm bearing as defined in 3.1 (refer to Figure 5.2).

### 5.2.3 Top surface of footing

#### 5.2.3.1 Provision of nib

Earth walls shall be provided with a concrete and/or fired brick nib beneath them that is either continuous with the footing or cast on top of the footing that shall be the width of the earth wall above, except that earth brick walls shall overhang the nib by 5 mm on the exterior face. There shall be a damp-proof course or other damp-proofing treatment between the top of the nib and the earth wall as required by 5.6.5.

#### 5.2.3.2 Clearance from floor to nib

The top of the footing and/or nib at the underside of the earth wall shall be:

- (a) A minimum of 50 mm; and
- (b) A maximum of 150 mm above finished floor level.

#### C5.2.3.2

*The clearance above interior floor level is to avoid soaking of wall base by water ponding during construction and/or water damage to the earth wall during the life of the building.*

#### 5.2.3.3 Bevel on nib

Where practicable, the top exterior edge of the nib shall have a bevel of 8 mm to 10 mm.

#### C5.2.3.3

*This bevel may not be feasible with a fired brick nib.*

### 5.2.4 Exterior surface to floor level

*The interior finished floor level shall be a minimum of 225 mm above the exterior surface for unprotected ground or 150 mm for permanent paving. Refer to Figure 5.2.C5.2.4. This provision is to limit the chance of external water levels flooding a floor.*

### 5.2.5 Compacted fill

Compacted granular fill under footings and floors shall comply with 5.6.3.3.

#### C5.2.5

*Fill deeper than 600 mm is outside the limitations defined in 1.2(d) and will require SED.*

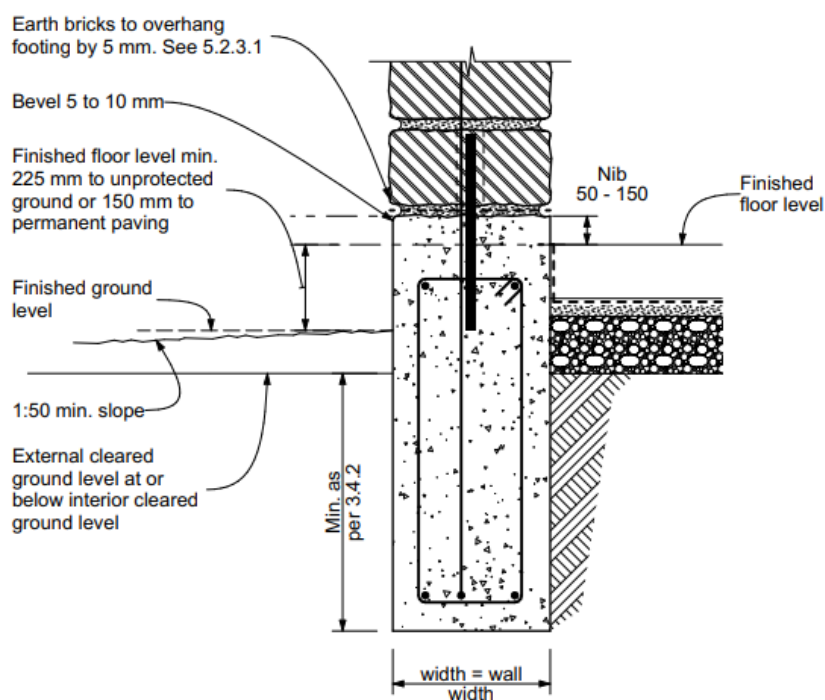

Figure 5.2 – Footing height clearances

## 5.3 Reinforcement of footings

### 5.3.1 Earthquake zones

#### 5.3.1.1 Reinforcement of footings in earthquake zone 1

Longitudinal reinforcement shall consist of two D12 bars at the top, and two D12 bars at the bottom for footings not exceeding 450 mm wide, see Figure 5.3.

#### 5.3.1.2 Reinforcement of footings in earthquake zones 2 and 3

Longitudinal reinforcement shall consist of two D16 (or two HD12) top and bottom for footings not exceeding 450 mm wide. Refer to Figure 5.4.

### 5.3.2 Re-bending bars

Where HD500 (or HD) bars are used they may only be re-bent once during construction.

### 5.3.3

Footing reinforcement shall be tied with R10 rectangular stirrups at 400 mm centres or as shown in Figure 5.3 except where there is a concrete floor, in which case the floor ties shall be D10 at 400 mm centres lapping 400 with the mesh as shown in Figure 5.7 to Figure 5.10. For foundations with an overall depth of less than 450 mm, the above spacings shall be 300 mm.

#### C5.3.3

For the configuration with brick facing shown in Figure 5.9, the footing will need to be sufficiently wide to accommodate the bricks, their mortar bedding, the reinforcing, stirrups, and cover.

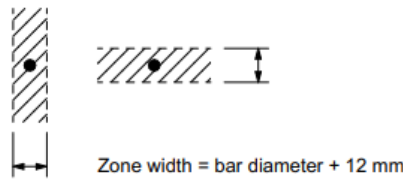
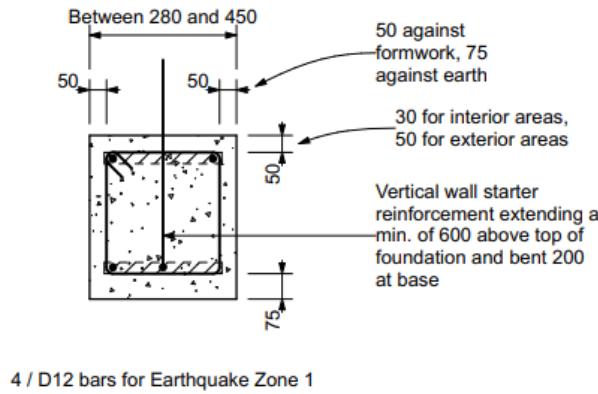

Figure 5.3 – Footing reinforcement in earthquake zone 1.

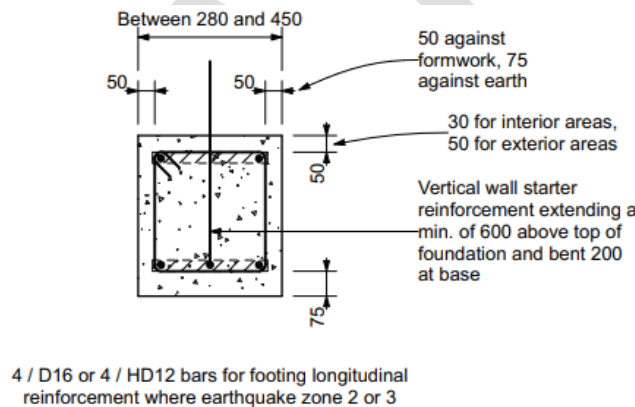

Figure 5.4 – Footing reinforcement in earthquake zone 2 or 3

**5.3.4 Corners and intersection of concrete footings**

Horizontal reinforcement at the corners and intersections of footings shall be continuous, or provided with L bars, or U bars for T intersections, as shown in Figure 5.5, with minimum lap lengths and bar bend radii as specified below.

Minimum lap lengths are:

- (a) Grade 300 reinforcing, 40 times the bar diameter;
- (b) Grade 500 reinforcing, 60 times the bar diameter.

Minimum bar bend radius shall be five times the bar diameter. The minimum diameter of the bend is measured on the inside of the bar.

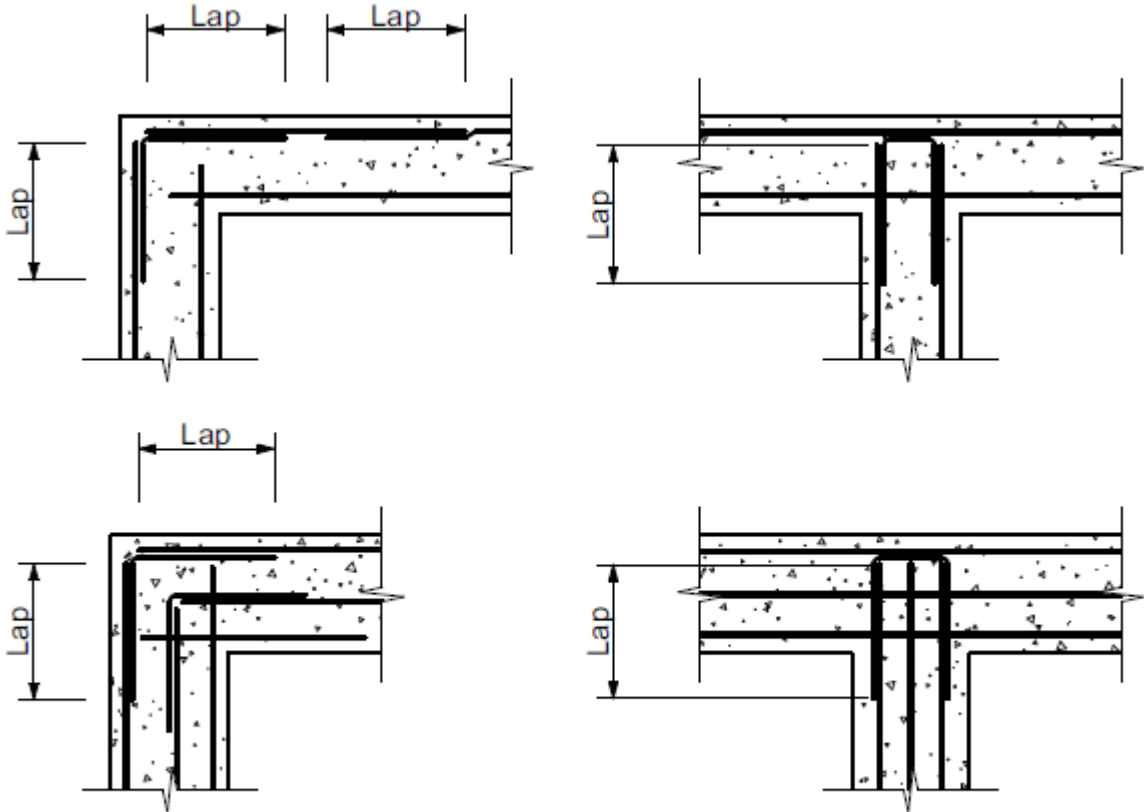

NOTE- All lap lengths shall comply with 5.3.4

Figure 5.4 – Reinforcement at footing or bond beam intersections

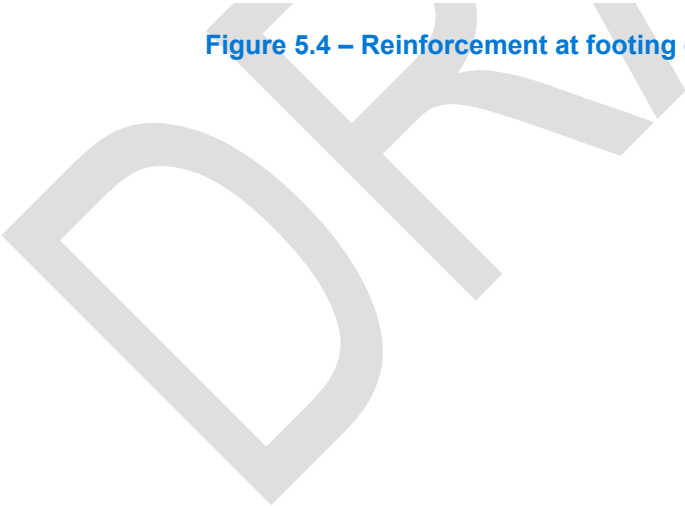

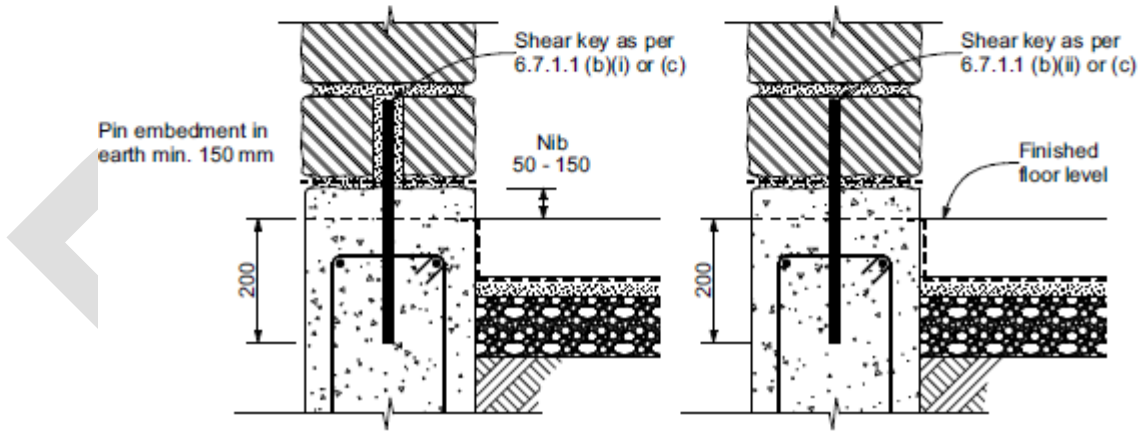
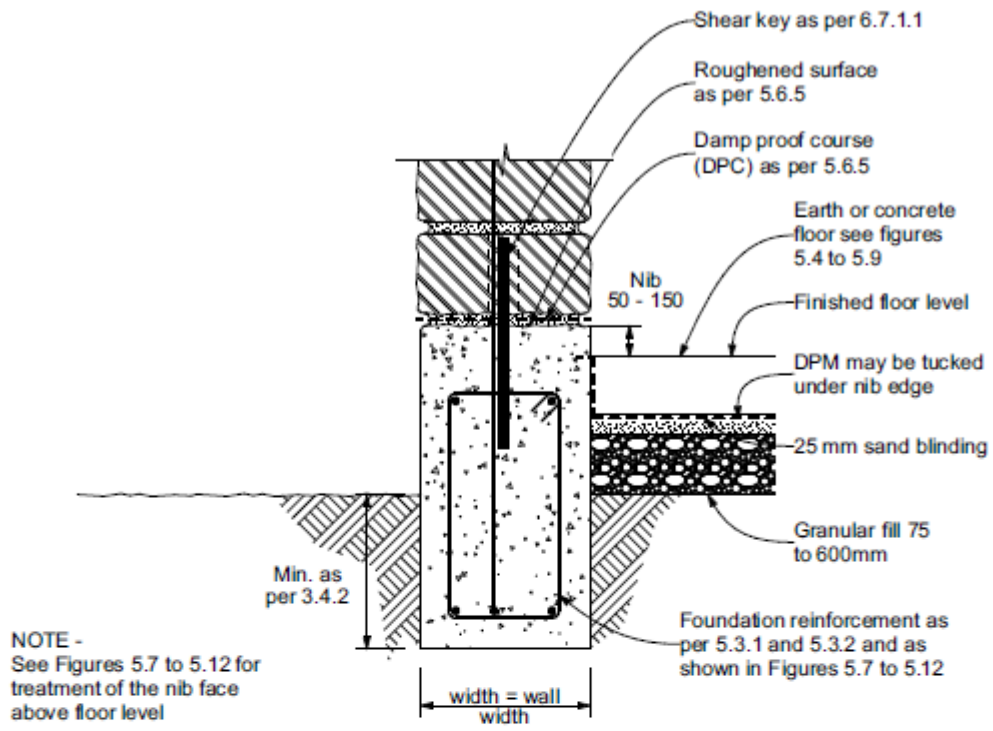

Figure 5.5 – Footings –general details including shear key options

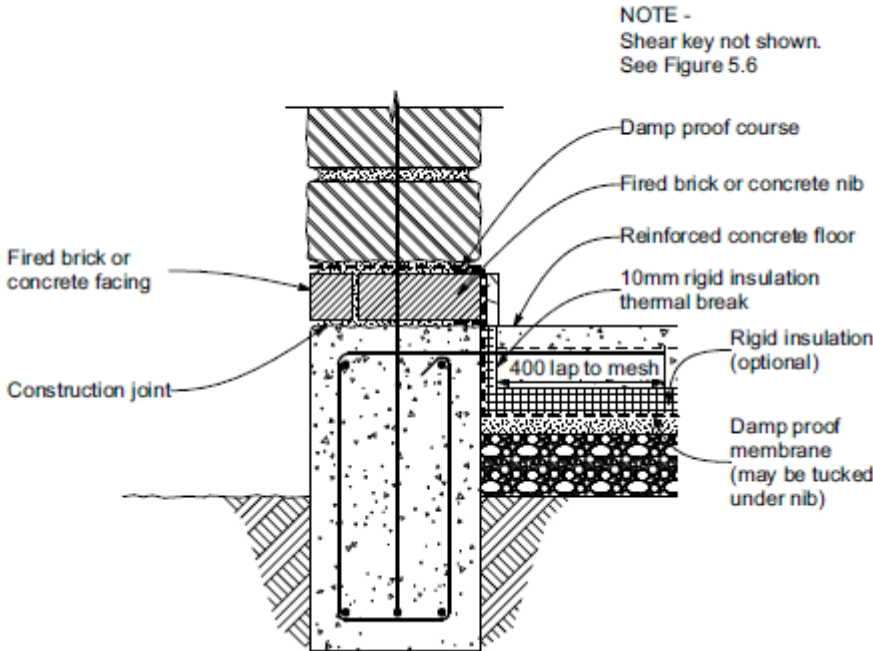

Figure 5.6 – Footing – Insulated concrete floor

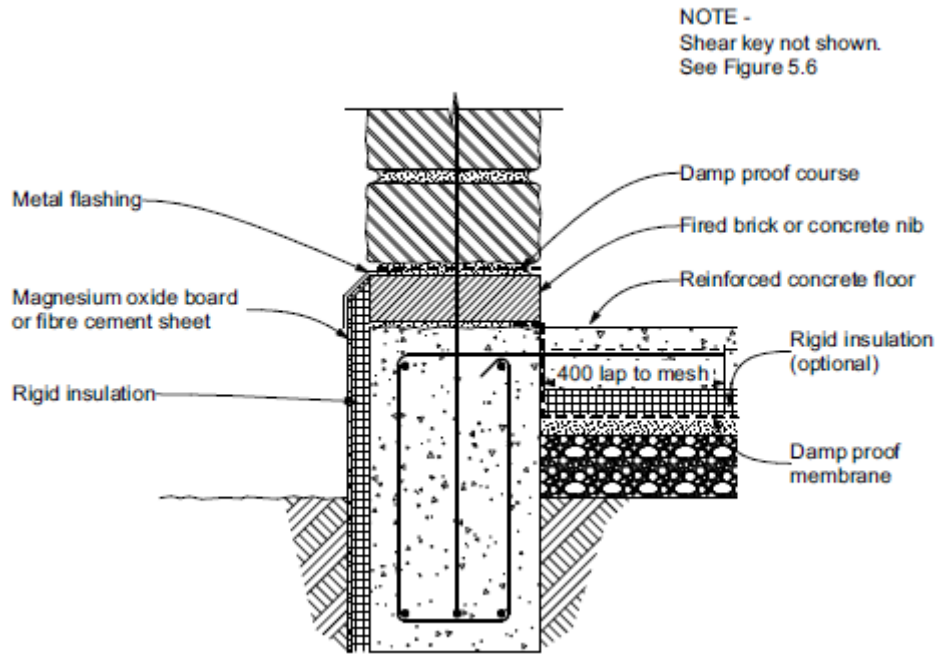

Figure 5.7 – Footing – Insulated slab and footing

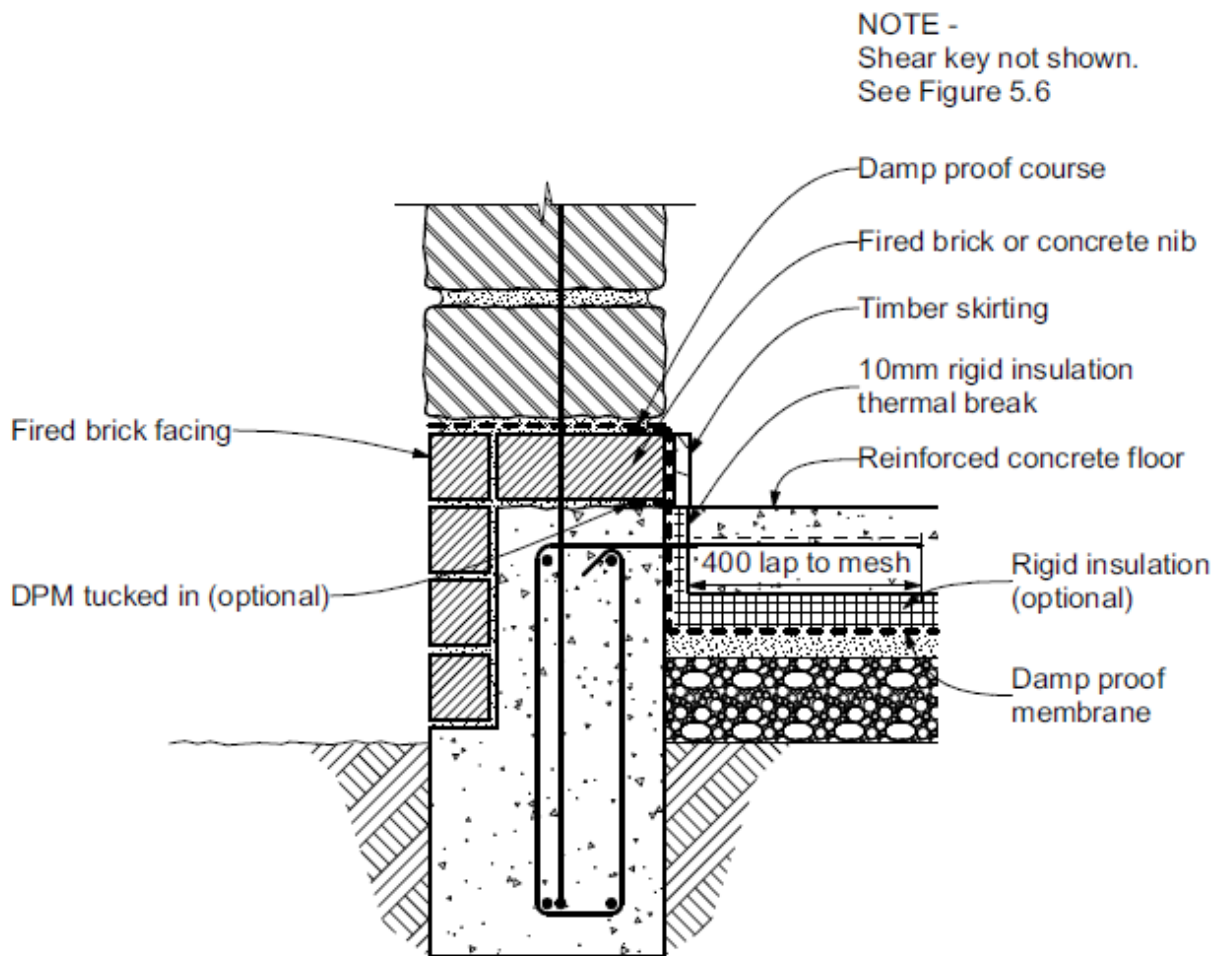

Figure 5.8 – Footing – Insulated slab with brick facing

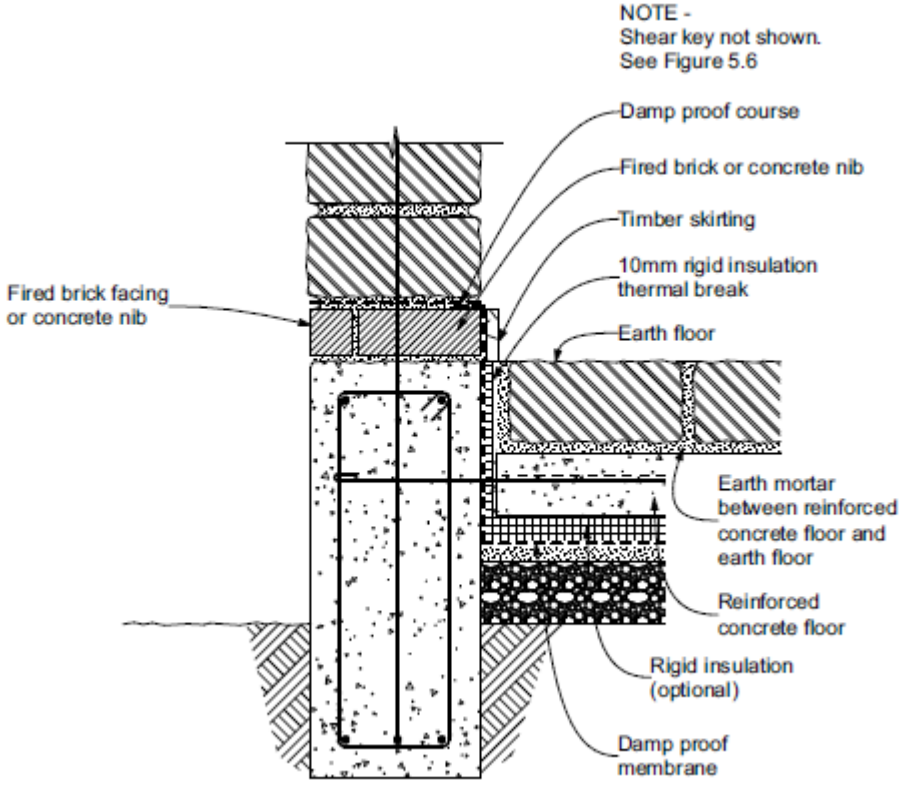

Figure 5.9 – Footing – Insulated earth floor on slab

DRAFT



NOTE -  
Shear key not shown.  
See Figure 5.6

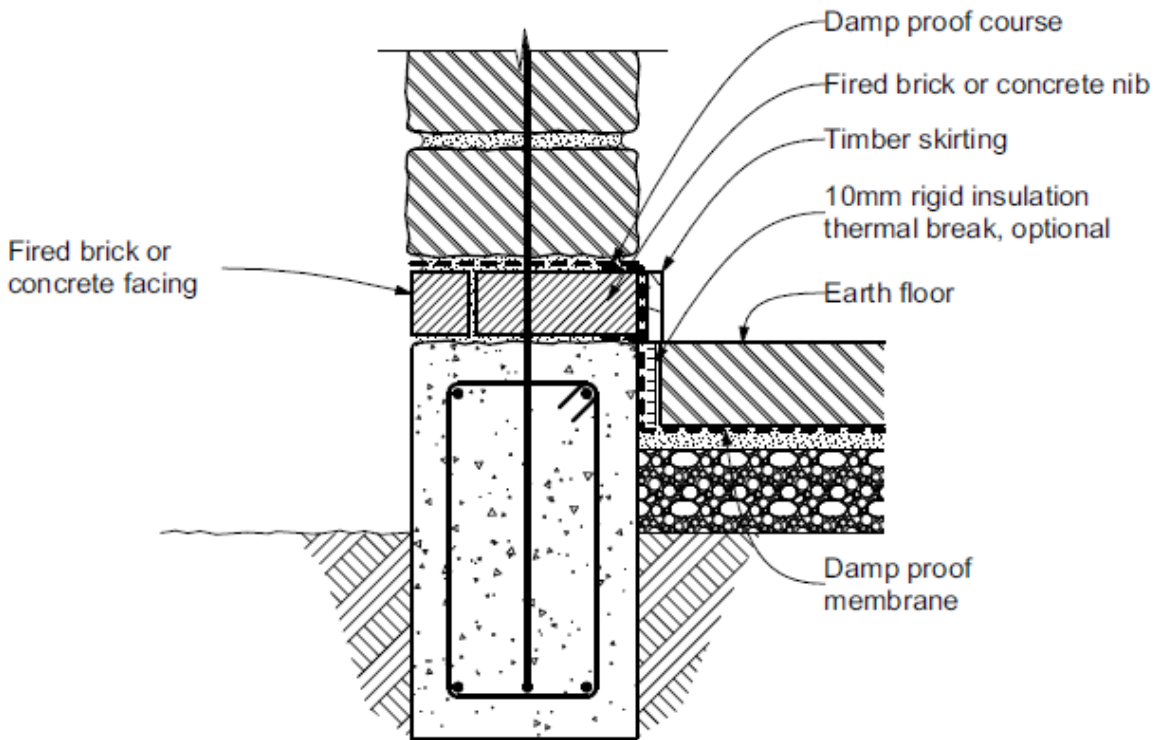

Figure 5.10 – Footing – Earth floor

NOTE -  
Shear key not shown.  
See Figure 5.6

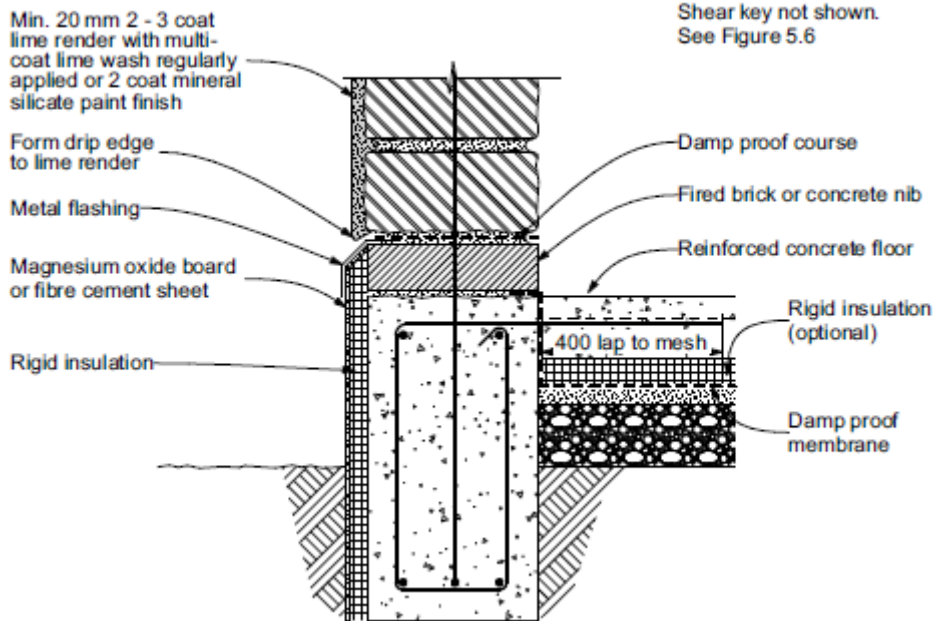

Figure 5.12 - Footing - Insulated footing and slab for lime render over solid earth wall

## 5.4 Cover to reinforcement

The cover to reinforcement in the footing shall be:

- (a) 75 mm to the bottom of the footing;
- (b) 75 mm to the sides when cast against earth and 50 mm when cast against formwork;
- (c) 50 mm minimum to the top of the footing.

Refer to Figure 5.3 and Figure 5.4.

## 5.5 Vertical wall starter reinforcement

### 5.5.1

Vertical wall starter reinforcement of the same diameter, type, spacing, and location as the wall vertical reinforcement shall be provided in every footing.

### 5.5.2

Vertical wall starter reinforcement shall be tied and anchored by the provision of a 90° bend contained in the bottom of the footing followed by a horizontal leg of 200 mm.

## 5.6 Concrete slab-on-ground floors

### 5.6.1 General

Concrete floor slabs, where provided, shall comply with the requirements NZS 3604 or NZS 4229 as modified by NZBC B1/AS1 and as modified by 5.6.

### 5.6.2

The finished concrete floor level shall be as specified in 5.2.4.

### 5.6.3 Bearing of footings and floor slabs

#### 5.6.3.1

The provisions of 5.2, relating to the minimum depth of footings below cleared ground level, shall apply to the footing walls but not to the ground slab itself. For external walls, the depth shall be measured from the cleared ground level outside the footing wall and not from the cleared ground level beneath the ground slab. For internal walls the depth shall be measured from the cleared ground level beneath the floor slab (see Figure 5.2).

#### 5.6.3.2

The cleared ground level beneath the slab shall be such that:

- (a) The granular fill material specified by 5.6.3.3 shall be placed either on solid bottom or on firm fill that complies with 3.1.2(e);
- (b) The thickness of granular fill shall be not less than 75 mm nor greater than 600 mm.

#### 5.6.3.3 Granular fill

The granular base shall comply with the following requirements:

- (a) It is placed and compacted in layers not exceeding 150 mm thick before compaction.
- (b) Granular fill material shall be composed of rounded gravel, crushed rock and:
  - (i) Not more than 5% shall pass a 2.2 mm sieve.
  - (ii) 100% shall pass either:
    - (A) 19 mm sieve for any fill thickness, or
    - (B) 38 mm sieve for a fill thickness exceeding 100 mm.

#### 5.6.3.4 Vapour barriers

The vapour barrier under the concrete slab shall comply with the requirements of NZS 3604.

#### 5.6.3.5 Thickness and reinforcement

The thickness and reinforcement and detail of concrete slabs shall comply with the requirements of NZS 3604 or NZS 4229 as modified by NZBC B1/AS1.

#### 5.6.4 Support of loadbearing timber internal walls

The support of loadbearing timber walls by a concrete floor shall comply with the requirements of NZS 3604.

#### 5.6.5 Damp-proof course

A damp-proof course shall be provided on the top of the foundation at the underside of the earth wall.

The top of the foundation shall be roughened to leave a minimum amplitude of 5 mm after the application of the damp-proof course.

The damp-proof course shall comprise one of the following:

- (a) The application of a spray-on penetrating hydrogel;
- (b) The application of a polymer modified cementitious waterproof mortar slurry; or
- (c) Three coats of bituminous paint that complies with AS/NZS 2904 for the full width of the earth wall.

The damp-proof course shall be applied to manufacturer's recommendations.

Alternatively, a waterproofing admixture can be added to the foundation concrete at the time of batching in lieu of the damp-proof course.

#### 5.6.6 Footing construction details

Footing construction details for earth wall construction in accordance with this standard shall be as shown on Figure 5.1 to [Figure 5.12](#).

## 6 WALLS

### 6.1 General

#### 6.1.1 Scope

Section 6 applies to earth walls with a thickness from 280 mm to 450 mm exclusive of any surface finishes including plaster.

Section 6 does not apply to internal adobe brick veneer walls that are covered by [Appendix F](#).

#### **C6.1.1**

*Earth buildings with earth walls thicker than provided for in 6.1.1 are outside the scope of this standard and will require SED.*

#### 6.1.2

The wall system shall consist of:

- (a) A wall system of earth specified by 6.2 to resist vertical loads. These walls may be combined with loadbearing light timber framing walls;
- (b) A wall system of earth specified by 6.3 to resist horizontal loads; combined with
- (c) Any other wall that is non-loadbearing, which shall be of light timber framing and shall not be taken into account for the purposes of 6.1.2(a) and (b).

#### 6.1.3

Structural diaphragms complying with section 7 or bond beams complying with section 8 shall be provided at the top of all earth walls.

#### **C6.1.3**

*Generally structural diaphragms are recommended in preference to bond beams.*

#### 6.1.4

Openings on external walls shall be located a minimum of 900 mm from the outside edge of an external corner.

#### 6.1.5

Earth wall panels between openings shall have a minimum length of 600 mm in earthquake zones 1 and 2 and a minimum length of 750 mm in zone 3.

#### 6.1.6 External wall surface

The external surface of earth walls shall be finished in accordance with NZS 4298, section 8. The external surface of earth walls shall be free from features, such as horizontal protrusions, that could cause water to become trapped or directed towards the inside of the building.

#### **C6.1.6**

*Water needs to be able to flow downwards and off the external surface of earth walls. External earth wall surfaces are not required to have a surface coating to meet this standard. The use of surface coatings does not replace or diminish the need for eaves as required by 2.7.*

### 6.2 Wall systems to resist vertical loads

#### 6.2.1

The wall system to resist vertical loads shall be such that all roof framing members shall be directly supported by any of the following or any combination of them:

- (a) Structural walls constructed of earth;
- (b) Loadbearing timber framing in accordance with NZS 3604 that may be supported on earth walls;
- (c) Timber lintels in accordance with NZS 3604 that may be supported on earth walls;
- (d) Reinforced concrete or timber lintels complying with section 9;
- (e) Another roof member;

(f) Reinforced concrete footing walls and footings.

### 6.2.2

No earth walls within the scope of this standard shall be supported on a timber structure, except for timber lintels in accordance with section 9.

### 6.2.3

Lintels shall be fixed to earth walls in accordance with section 9.

## 6.3 Earth wall systems to resist horizontal loads

### 6.3.1 General

All earth buildings shall be braced by earth bracing walls in each of the two principal directions of the building, at 90° to each other, to resist horizontal wind and earthquake loads.

### 6.3.2 Total bracing capacity

The total bracing capacity of all walls bracing panels in each of two directions at right angles to each other shall be not less than the design bracing demand from 4.4.

#### C6.3.2

*The total number of BUs given by section 4 for earthquake bracing demand will be the same for each of the two directions that are to be considered. The total number of BUs given by section 4 for wind bracing demand will be different for the two directions (except for square buildings).*

*For earth buildings within the scope of this standard, the requirements for walls to be able to resist wind loads will in most cases be met or exceeded by the provisions required to resist earthquake loads, except for buildings in a very high wind zone or for buildings with earth wall material with a density less than 1200 kg/m<sup>3</sup>.*

### 6.3.3 Bracing capacity for wings or blocks not at right angles.

Where in any building consisting of wings or blocks that are not at right angles to each other, this requirement for bracing capacity shall be satisfied individually for each such wing or block.

### 6.3.4 Wall bracing elements in external walls

Each external wall shall contain a total number of bracing units not less than that required for a tributary floor area being either half the distance between the external bracing line and next adjacent bracing line or 2.0 m, whichever is greater over the wall length for the building being considered calculated as follows:

- For earthquake: The overall length of the wall, including windows and openings, in metres multiplied by the external tributary width (2.0 m minimum) multiplied by the number of bracing units per square metre required by 4.2.4 (k) for earthquake;
- For wind: The greatest width of either 2.0 m or half the spacing to the next parallel bracing line multiplied by the number of bracing units per metre of building plan dimension from 4.3.

For the purposes of (a) and (b) above, where offsets occur along the side of a building, the wall length shall be taken as the total length of all parallel external walls that are offset not more than 2.0 m from one another.

#### C6.3.4

*This clause requires a minimum bracing capacity equivalent to that needed to laterally support a roof width of 2.0 m and the external wall.*

*The external tributary width is half the distance between the external bracing line and next adjacent bracing line. This clause requires a minimum bracing capacity equivalent to that needed to laterally support a roof width of 2.0 m and the external wall. Figure B.1 in Appendix B illustrates determining the tributary areas for a simple building.*

### 6.3.5 Wall bracing elements in internal walls on bracing lines

Bracing lines shall be parallel to external walls except as provided by 6.3.3 above.

Each internal wall exceeding 3.0 m in length shall contain a total number of bracing units not less than:

- (a) For earthquake: The length of the wall in metres multiplied by the internal tributary floor width (3.0 m minimum) multiplied by the number of bracing units per square metre required by 4.2.4 (k) for earthquake;
- (b) For wind: The greatest width of either 3.0 m or half the spacing between the two next adjacent parallel bracing lines multiplied by the number of bracing units per metre of building plan dimension from 4.3.

The total bracing demand at any internal bracing line as specified in 6.3.5 may be reduced by up to 30% provided the total bracing capacity of the building in each direction complies with the minimum number of bracing units specified in 6.3.2.

### C6.3.5

*The internal tributary width is half the spacing between the two bracing lines adjacent to the internal bracing line being assessed.*

### 6.3.6

The centrelines of parallel bracing lines shall be not more than 6.0 m apart. Refer to Figure 6.1.

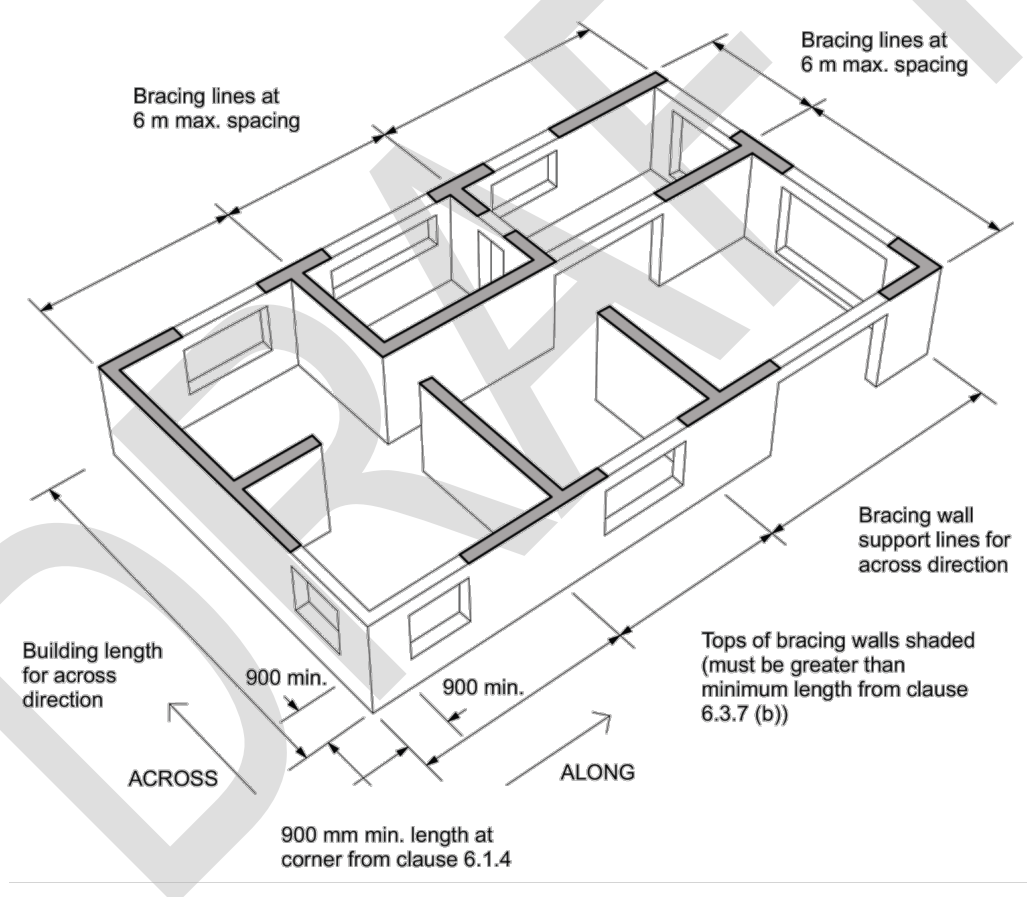

**Figure 6.1 – Bracing line support system and openings at external corners**

**6.3.7**

The earth walls of a building that are considered to provide bracing capacity shall be:

Full height panels with a minimum height of 1.8 m.

- (a) A minimum length, with no openings within the panel between the footing and top plate or bond beam, of:
- (i) 1.2 m for walls up to 2.4 m high
  - (ii) 1.5 m for walls up to 3.0 m high
  - (iii) 1.8 m for walls up to 3.3 m high;

- (b) The maximum length of panels in long walls without openings is controlled by the spacing of control joints where required. [The position and maximum spacing of control joints is shown in NZS 4299 section 11.](#)

**6.3.8**

The length of a bracing wall shall be the horizontal length along the wall between wall ends, openings, corners, or control joints.

**6.3.9**

Subject to the requirements of 6.4, and 8.3, wall bracing elements shall as far as is practicable be located at the corners of external walls and evenly throughout the buildings.

**C6.3.9**

*The horizontal torsional resistance of buildings to resist earthquake and wind forces are best served by wall bracing elements placed uniformly around a structure. The most effective locations for wall bracing are those extremities of the floor plan such as at external corners.*

**6.3.10**

The bracing capacity in each of the outside walls in each direction shall be such that the bracing capacity in one outside wall is not less than 50% of the total of the bracing capacity in the opposite, parallel outside wall.

**6.3.11**

Bracing walls may be a maximum of 1.0 m either side of the bracing wall support line and contribute to the total bracing capacity for that support line. No wall supported laterally by connections to other walls shall be longer than 6.0 m between the centres of those connections.

**C6.3.11**

*The bracing wall support line chosen is to represent the combined line of action of all walls considered to act on that line and bracing walls may be a maximum of 1.0 m either side of the bracing wall support line.*

**6.3.12**

Where bracing walls are at the following angles to the bracing wall support line, they may contribute to the total bracing capacity of that support line as follows:

- (a) 30° to one direction and 60° in the other direction, 0.87 and 0.5 times the bracing capacity of the bracing wall.
- (b) 45° to both directions, 0.7 times the bracing capacity of the bracing wall.
- (c) The factor for other angles shall be obtained by specific design and is outside the scope of this standard.

**6.3.13**

The effective height of a raking wall or gable end wall shall be taken as its average height determined as shown in Figure 6.2.

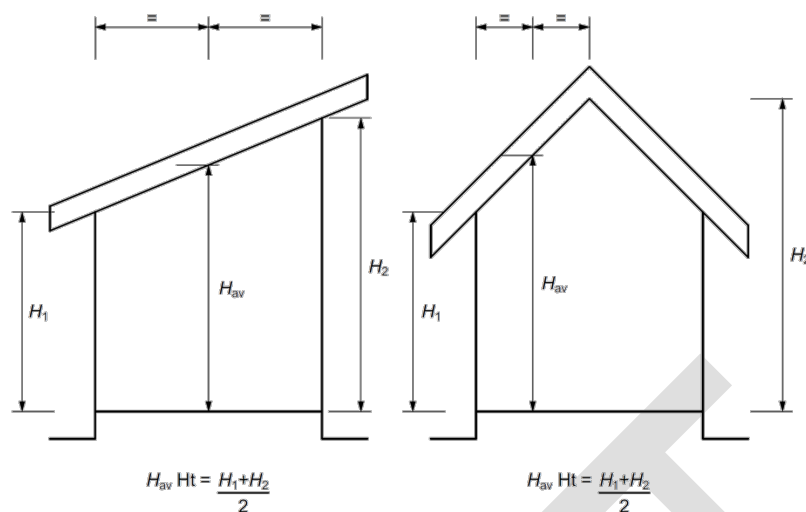

Figure 6.2 – Determining average wall height

**C6.3.13**

The average wall height determined from 6.3.13 is for the purposes of determining bracing demand and bracing capacity but is not to be used when assessing weather protection requirements of walls in accordance with 2.7.

**6.3.14 Bracing capacity of reinforced earth walls**

The bracing capacity of reinforced earth bracing walls shall be as shown in Table 6.1. Refer to 6.3.13 for the effective height of raking or gable end walls.

Table 6.1 – Bracing capacity of reinforced earth walls – Heavy earth (1400–2200 kg/m<sup>3</sup>)

| Wall length (L)<br>(m) | Wall heights<br>(m)           |              |              |              |
|------------------------|-------------------------------|--------------|--------------|--------------|
|                        | 2.4                           | 2.7          | 3.0          | 3.3          |
|                        | <b>Bracing units provided</b> |              |              |              |
| 1.2                    | 262                           | NA           | NA           | NA           |
| 1.5                    | 347                           | 309          | 278          | NA           |
| 1.8                    | 432                           | 384          | 346          | 314          |
| 2.1                    | 517                           | 459          | 413          | 376          |
| 2.4                    | 601                           | 535          | 481          | 437          |
| 2.7                    | 686                           | 610          | 549          | 499          |
| 3.0                    | 771                           | 685          | 617          | 561          |
| >3.0                   | 130 + 210 × L                 | 60 + 205 × L | 40 + 190 × L | 50 + 170 × L |

NOTE –

(1) Maximum wall heights are limited by 1.2(t).

(2) For low-density earth (from 800 up to 1400 kg/m<sup>3</sup>) assume bracing capacity of 80% of the bracing capacity of heavy earth as per the table above.

**6.4 Reinforcement of earth walls**



### 6.4.1 Vertical reinforcement

Earth walls shall have one HD12 (or HD12 threaded equivalent) vertical reinforcing bar at each end of all walls at a distance of 150 mm to 200 mm from the ends of the bracing wall as shown in Figure 6.3.

### 6.4.2 Sleeving vertical reinforcement in rammed earth

Vertical deformed or threaded reinforcing bar in rammed earth that is required by 6.4.1 shall be sleeved as required by NZS 4298, clause 2.8.2.6.

### 6.4.3 Vertical reinforcement spacing

Except as provided by 6.5.3, all adobe, cob, rammed earth, and pressed brick walls shall have vertical HD12 (or HD12 threaded equivalent) reinforcing bars at the average and maximum spacings shown in Table 6.2, Table 6.3, or Table 6.4 depending on the earthquake zone.

**Table 6.2 – Spacing of vertical reinforcement in earth walls in earthquake zone 1**

| Height of wall<br>(m) | Average spacing<br>(m) | Maximum spacing<br>(m) |
|-----------------------|------------------------|------------------------|
| 2.4                   | 1.65                   | 2.10                   |
| 2.7                   | 1.35                   | 1.80                   |
| 3.0                   | 1.05                   | 1.50                   |
| 3.3                   | 0.75                   | 1.20                   |
| 3.6 (gable end)       | 0.60                   | 0.75                   |

**Table 6.3 – Spacing of vertical reinforcement in earth walls in earthquake zone 2**

| Height of wall<br>(m) | Average spacing<br>(m) | Maximum spacing<br>(m) |
|-----------------------|------------------------|------------------------|
| 2.4                   | 1.05                   | 1.50                   |
| 2.7                   | 0.90                   | 1.20                   |
| 3.0                   | 0.75                   | 0.90                   |
| 3.3 (gable end)       | 0.60                   | 0.75                   |

**Table 6.4 – Spacing of vertical reinforcement in earth walls in earthquake zone 3**

| Height of wall<br>(m) | Average spacing<br>(m) | Maximum spacing<br>(m) |
|-----------------------|------------------------|------------------------|
| 2.4                   | 0.90                   | 1.20                   |
| 2.7                   | 0.75                   | 0.90                   |
| 3.0 (gable end)       | 0.60                   | 0.75                   |

### 6.4.4 Reinforcement of walls under openings

#### 6.4.4.1

Earth walls beneath openings in earth walls shall be reinforced with both vertical and horizontal reinforcement as required in adjacent walls. Vertical bars are not required where the earth wall is less than 450 mm high.

#### 6.4.4.2

A vertical bar shall be placed 150 mm from each end of the earth wall panel under any opening that is more than 800 mm wide. See Figure 6.3. For panels in earth walls under openings less than 800 mm wide, only one centrally placed vertical bar shall be required in that panel.

#### 6.4.4.3

Where the maximum height of an earth wall to the underside of any sill opening is greater than 1500 mm in

earthquake zone 1, or greater than 1200 mm in earthquake zones 2 and 3, then specific design shall be required.

#### 6.4.4.4 Reinforcement of walls under openings and tightening of nuts

Vertical reinforcing bars in all earth walls, except rammed earth walls, over 900 mm high but less than the heights in 6.4.4.3 shall be terminated with a nut and a 50 mm × 50 mm × 3 mm galvanised washer installed on a mortar bed immediately on top of the top row of horizontal reinforcing above a gringo block as detailed in Figure 10.8, 10.9, 10.11 and 10.15.

Recess the nut into the top of the earth wall in such a way that it can be accessed for tightening immediately before the windowsill is installed as per 6.4.5.3. Fill the nut-access hole with mortar.

#### 6.4.5 Tightening anchorage nuts

##### 6.4.5.1

Anchorage nuts shall be tightened to the force that most builders can exert on them using a 300 mm long wrench.

##### 6.4.5.2

The post-tensioning developed in accordance with 6.4.5.1 shall be re-established after any shrinkage of the earth wall.

##### C6.4.5.2

*Anchorage nuts should be checked and tightened in accordance with 6.4.5.1 at regular intervals until shrinkage has completed. Shrinkage is normally completed once there is no movement of the anchorage nut. Checks are typically carried out at 1 month, 3 months, 6 months, and 12 months after the earth wall is constructed. Additional checks may be required at 6-month intervals if the anchorage nut moves during the 12-month check or any further 6-monthly check. Full compliance with NZS 4299 requires that the nuts at the tops of all vertical reinforcing shall be sufficiently tight that no further tightening as per 6.4.5.1 is possible.*

##### 6.4.5.3

Where anchorage nuts are sited under openings such as at windows these shall be tightened down as per 6.4.5 and then checked again as per 6.4.5.2 prior to window sills being installed.

### 6.5 Reinforcement of rammed earth walls

#### 6.5.1 Vertical reinforcement

Reinforced rammed earth walls shall be constructed in accordance with 6.4 and as shown on Figure 6.3 with a HD12 vertical reinforcing rod sleeved within a 15 mm diameter PVC or polythene tube.

#### 6.5.2 Horizontal reinforcement

All reinforced rammed earth walls shall either have horizontal reinforcement as provided for in 6.5.4 or extra vertical reinforcing as provided in 6.5.3.

#### 6.5.3 Reinforcement for rammed earth walls without horizontal reinforcement

As an alternative to the provisions of 6.6 rammed earth walls may be constructed with no horizontal reinforcement embedded in the earth wall but with vertical steel HD12 steel bar reinforcement provided in accordance with Table 6.5, Table 6.6, or Table 6.7 depending on the earthquake zone.

##### C6.5.3

*For SED by engineers, rammed earth walls without horizontal reinforcement are to be designed to the elastic response method.*

#### 6.5.4 Reinforcement of rammed earth walls under openings

Vertical reinforcing bars in rammed earth walls over 900 mm high but less than the heights in 6.4.4.3, shall be terminated with a nut and a 50 mm × 50 mm × 3 mm galvanised washer or an 80 mm × 80 mm × 6 mm washer installed immediately on top of the completed rammed earth wall. Horizontal reinforcing is not required at the top of a rammed earth wall under openings. Maintain 100 mm rammed earth cover to the top of the rods, with a shrinkage gap as described in Table 10.1 between the top of the reinforcing rod and the underside of the sill above to allow for vertical shrinkage caused by drying.

#### **C6.5.4**

*Refer to Figures 10.8 and 10.9, 10.11 and 10.15 for the details for timber or aluminium joinery with brick or tile sills.*

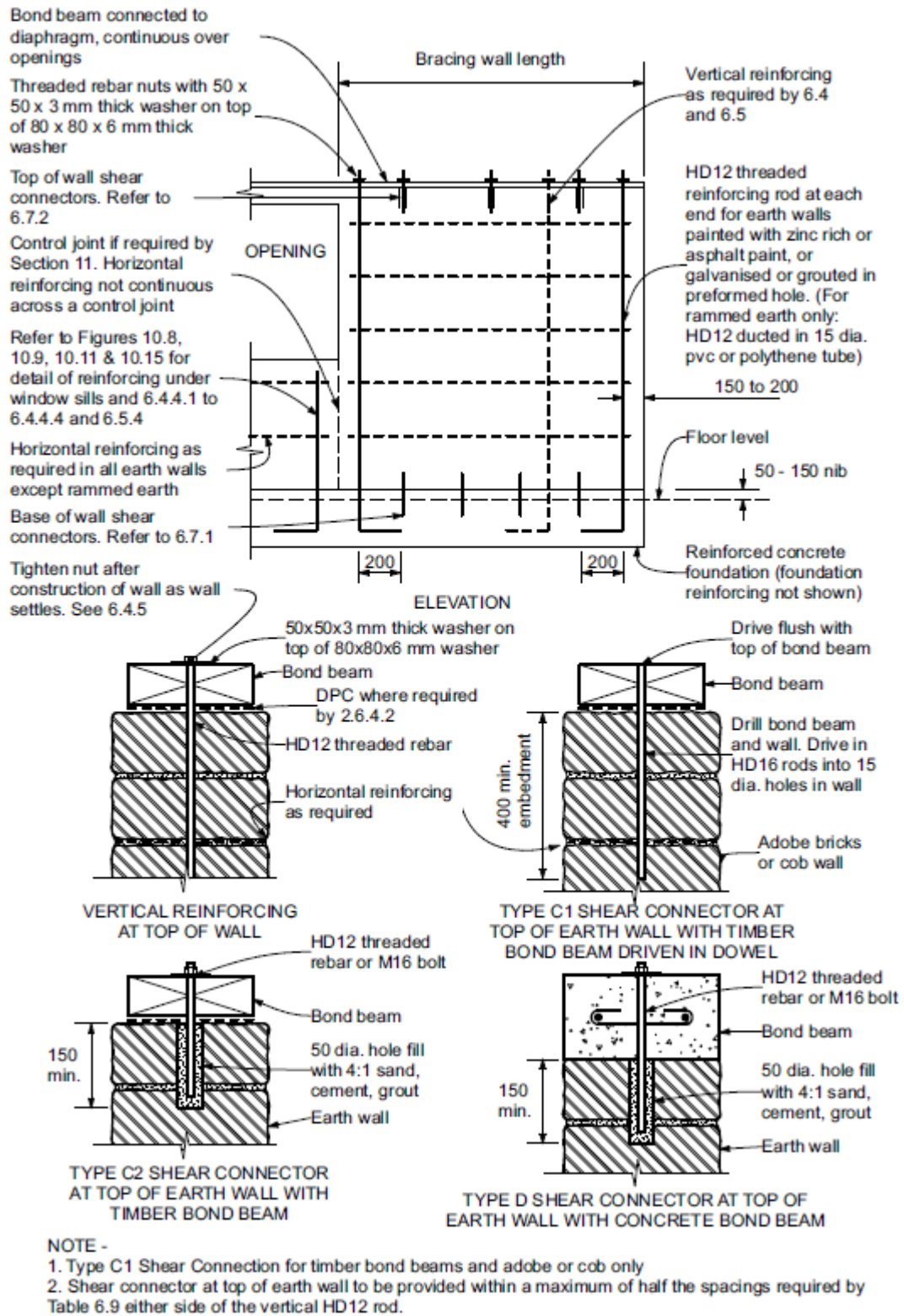

Figure 6.3 – Reinforcing and shear connectors for reinforced earth walls

**Table 6.5 – Spacing of vertical HD12 reinforcement in rammed earth walls without horizontal reinforcement in earthquake zone 1**

| Height of wall<br>(m) | Average spacing<br>(m) | Maximum spacing<br>(m) |
|-----------------------|------------------------|------------------------|
| 2.4                   | 1.15                   | 1.50                   |
| 2.7                   | 0.95                   | 1.20                   |
| 3.0                   | 0.70                   | 0.90                   |
| 3.6 (gable end)       | 0.50                   | 0.60                   |

**Table 6.6 – Spacing of vertical HD12 reinforcement in rammed earth walls without horizontal reinforcement in earthquake zone 2**

| Height of wall<br>(m) | Average spacing<br>(m) | Maximum spacing<br>(m) |
|-----------------------|------------------------|------------------------|
| 2.4                   | 0.90                   | 1.20                   |
| 2.7                   | 0.75                   | 0.9                    |
| 3.0                   | 0.60                   | 0.75                   |
| 3.3 (gable end)       | 0.45                   | 0.60                   |

**Table 6.7 – Spacing of vertical HD12 reinforcement in rammed earth walls without horizontal reinforcement in earthquake zone 3**

| Height of wall<br>(m) | Average spacing<br>(m) | Maximum spacing<br>(m) |
|-----------------------|------------------------|------------------------|
| 2.4                   | 0.75                   | 0.90                   |
| 2.7                   | 0.60                   | 0.75                   |
| 3.0 (gable end)       | 0.45                   | 0.60                   |

## 6.6 Horizontal reinforcement

### 6.6.1 Reinforcement types

Except as provided by 6.5.3, all reinforced earth walls 280 mm to 450 mm thick shall have horizontal reinforcement that shall comprise one of the following alternatives:

- (a) Wire steel mesh reinforcing in accordance with 6.6.2; or
- (b) Polypropylene geotechnical mesh such as polypropylene biaxial or triaxial geogrid mesh in accordance with 6.6.3.

### 6.6.2 Steel reinforcing ladder cut from wire mesh

For steel reinforcement, 5.3 mm diameter wire cut from 665 or SE62 steel mesh reinforcing with 100 mm long cross wires shall be placed at 450 mm centres maximum vertically in mortar joints as shown in Figure 6.4.

The use of steel reinforcement cut from mesh is limited by the durability requirements of 2.1.5

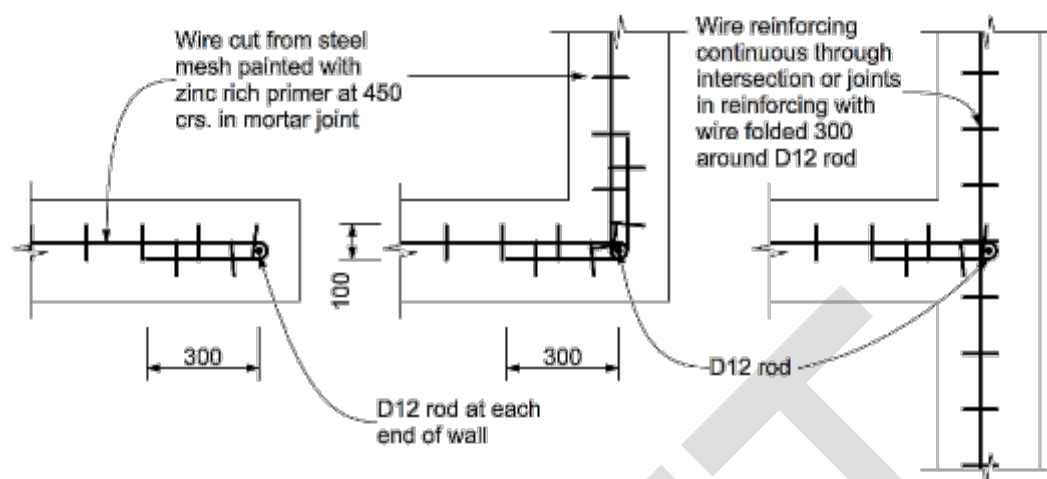

**Figure 6.4 – Horizontal reinforcement cut from steel mesh**

### 6.6.3 Polypropylene geogrid

Polypropylene geotechnical material such as polypropylene biaxial or triaxial geogrid with apertures 25 to 50 mm wide shall be installed at the following centres depending on its ultimate quality control strength as determined in accordance with BS EN ISO 10319:2015:

- (a) 450 mm centres where the quality control strength is 40 kN/m; or
- (b) 300 mm centres where the quality control strength is 30 kN/m.

The strips of geotextile shall be the width of the wall less 40 mm each side (that is, the wall width minus 80 mm) as shown in Figure 6.5.

A 6 mm × 200 mm HDPE bodkin or 6 mm diameter minimum galvanised steel rod, 200 mm long threaded through the geogrid, shall anchor the geogrid to the vertical reinforcing. The geogrid shall be pulled tight and fixed in place prior to being covered by earth wall material.

#### **C6.6.3**

*The geogrid may be tightened by use of a wider bodkin or larger diameter rod.*

*More closely spaced geogrid at 300 mm centres is preferred to geogrid at 450 mm centres.*

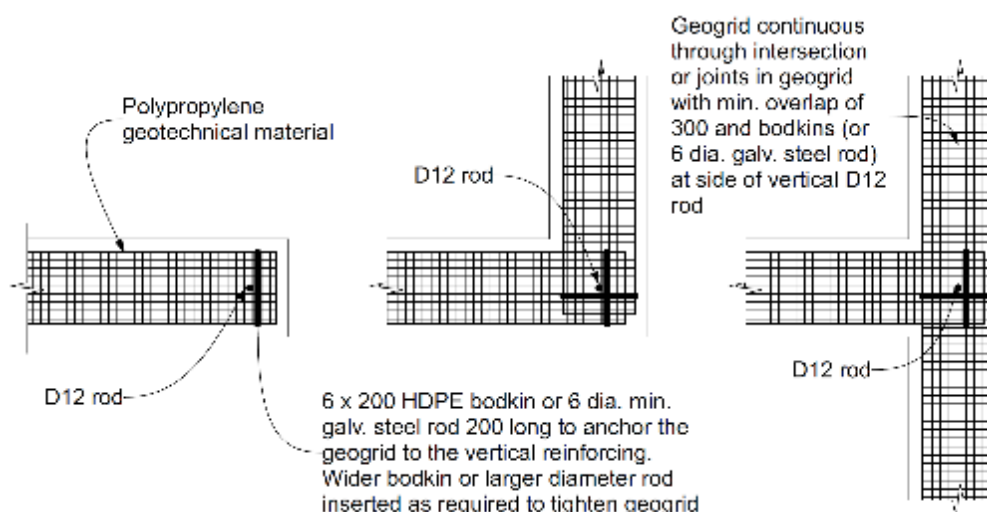

**Figure 6.5 – Horizontal reinforcement for earth walls**

### 6.6.4 Joints in horizontal reinforcing

Each horizontal reinforcing member shall be in a single continuous length without laps between ends of bracing walls. Joints in horizontal reinforcing shall be located at vertical steel reinforcing rods at ends of bracing walls. A minimum overlap of the mesh width with a bodkin or 6 mm diameter rod either side of the vertical steel reinforcing rod shall be provided for joints in geogrid horizontal reinforcing.

## 6.7 Shear connections

### 6.7.1 Base of walls

#### 6.7.1.1 Requirements for different earthquake zones

Roughen the foundation top surface to an amplitude of 5 mm **before** application of any damp-proof course, and for the following earthquake zones:

- (a) Earthquake zone 1 – There is no requirement other than roughening the foundation and using the vertical reinforcing rods required by 6.4;
- (b) Earthquake zone 2 – There are two options:
  - (i) Shear connectors shall be used at vertical reinforcing rods and additional Type A shear connectors at 900 mm maximum centres. The additional shear connectors are to be D12 or HD12 rods cast 200 mm into the foundations below the nib and extending 150 mm into the base of the earth wall. Both the shear connectors and vertical reinforcement in the earth wall are to have a concrete cylinder cast around them a minimum of 50 mm diameter and 150 mm tall (see Figure 5.6), or
  - (ii) The vertical reinforcing rods shall have the concrete cylinders as for (i) above. Additional Type B shear connectors at 600 mm maximum centres shall be D16 or HD16 rods at cast 200 mm into foundations below the nib and extending 150 mm into the base of earth walls but without the cast concrete cylinder required in (i) above (see Figure 5.6);
- (c) Earthquake zone 3 – Shear connectors shall be used as for earthquake zone 2 but at maximum 600 mm centres for the Type A connectors and at maximum 450 mm centres for Type B connectors.

The required spacings are shown in Table 6.8.

Table 6.8 – Spacing of shear connectors at base of earth walls

|                |                 | Maximum spacing of shear connectors<br>(mm) |     |  |
|----------------|-----------------|---|-----|--|
| Connector type | Earthquake zone |   |     |  |
|                | 1               | 2   | 3   |  |
| Type A         | Not required    | 900   | 600 |  |
| Type B         | Not required    | 600   | 450 |  |

### 6.7.1.2 Installation

For earthquake zones 2 and 3, as detailed in 6.7.1.1(b) and (c) the shear connectors shall be installed as follows:

- (a) In adobe and pressed brick – Shear connectors are to be located in drilled or cast in holes in the brick and embedded in cement mortar.
- (b) Cob and in-situ adobe – The earth is to be placed so that the shear connectors are thoroughly embedded.
- (c) Rammed earth – Earth is to be rammed around the shear connectors.

### 6.7.2 Top of walls - Requirements for different earthquake zones

Leave the tops of earth walls with a roughened surface with an amplitude of 5 mm if pouring a concrete bond beam, and for the following earthquake zones:

- (a) Earthquake zone 1 – No additional shear connectors are required other than the vertical reinforcing rods as required by 6.4.
- (b) Earthquake zone 2:
  - (i) Where using timber bond beams, Type C shear connectors at 600 mm centres in addition to the vertical reinforcing shall be used. Type C shear connectors shall be either:
    - (A) Type C1 HD16 mm rods driven through the timber bond beam and 400 mm into the top of the earth wall in a 15 mm diameter predrilled hole or
    - (B) Type C2 HD12 threaded bars or 16 bolts, sand/cement grouted into a 50 mm diameter by 150 mm deep hole in the earth wall (see Figure 6.3).
    - (C) Type D Where using concrete bond beams, Type D shear connectors at 900 mm centres in addition to the vertical reinforcing shall be used. Type D shear connectors shall be concrete dowels cast integrally with the bond beam that are 50 mm by 150 mm deep holes drilled or cast into the earth wall and with an HD12 rod (see Figure 6.3).
- (c) Earthquake zone 3 – Follow the requirements for zone 2 in (b) above but with connectors or dowels at 450 mm centres for Type C and 600 mm centres for Type D.

The required shear connector spacings for wall tops are shown in Table 6.9

Table 6.9 – Spacing of shear connectors at top of earth walls

|                    |                | Maximum spacing of shear connectors<br>(mm) |     |     |
|--------------------|----------------|---|-----|-----|
| Bond beam material | Connector type | Earthquake zone                             |     |     |
|                    |                | 1   | 2   | 3   |
| Timber             | Type C         | Not required                                | 600 | 450 |
| Concrete           | Type D         | Not required                                | 900 | 600 |



### 6.7.3 Lintels

Earth walls above lintels shall be connected with D12 or HD12 shear connectors a minimum of 70 mm into the lintel and 300 mm into the earth wall at 600 mm maximum centres in earthquake zones 1 and 2 and at 450 mm maximum centres in earthquake zone 3. Geogrid or steel reinforcing shall be placed above the lintel at a minimum of 100 mm in rammed earth or one course in cob, adobe, or pressed brick.

Shear connectors shall be installed as follows:

Drill a 70 mm deep 11 mm diameter hole into the top of the timber lintel. Drive the D12 or HD12 rod 70 mm into the 11 mm diameter hole in the top of the lintel.

- (a) Adobe and pressed brick - Shear connectors are to be located in drilled or cast in holes in the brick and embedded in the same mortar as used for horizontal mortar joint.
- (b) Cob and in-situ adobe - The earth is to be placed so that the shear connectors are thoroughly embedded.
- (c) Rammed earth - Earth is to be rammed around the shear connectors.

#### **C6.7.3**

*Positive connection at the wall to footing and lintel interface and the wall to bond beam interface is necessary to prevent sliding in earthquakes.*

### 6.8 Soffit-to-wall junction

The junction between the soffit and the earth wall may be constructed as shown in Figure 6.6 and 6.7

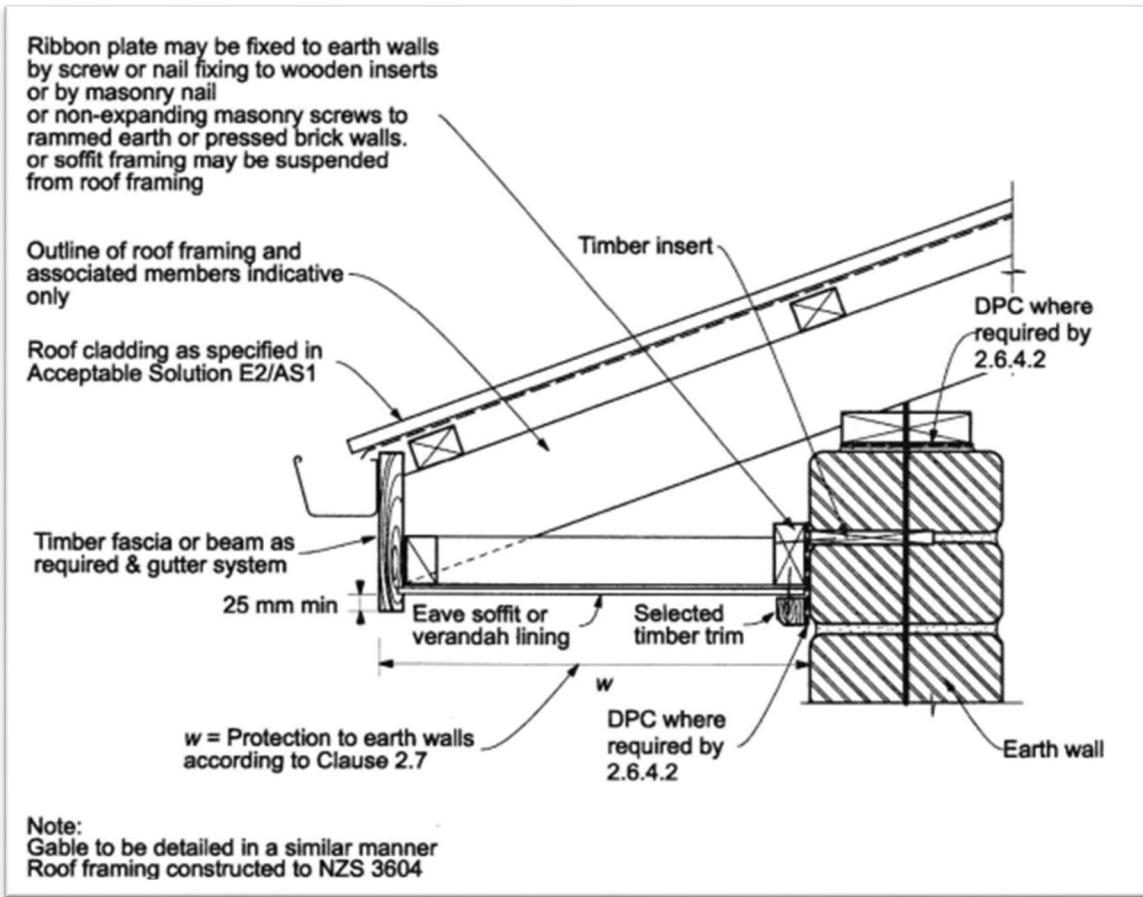

Figure 6.6 – Soffit-to-wall junction

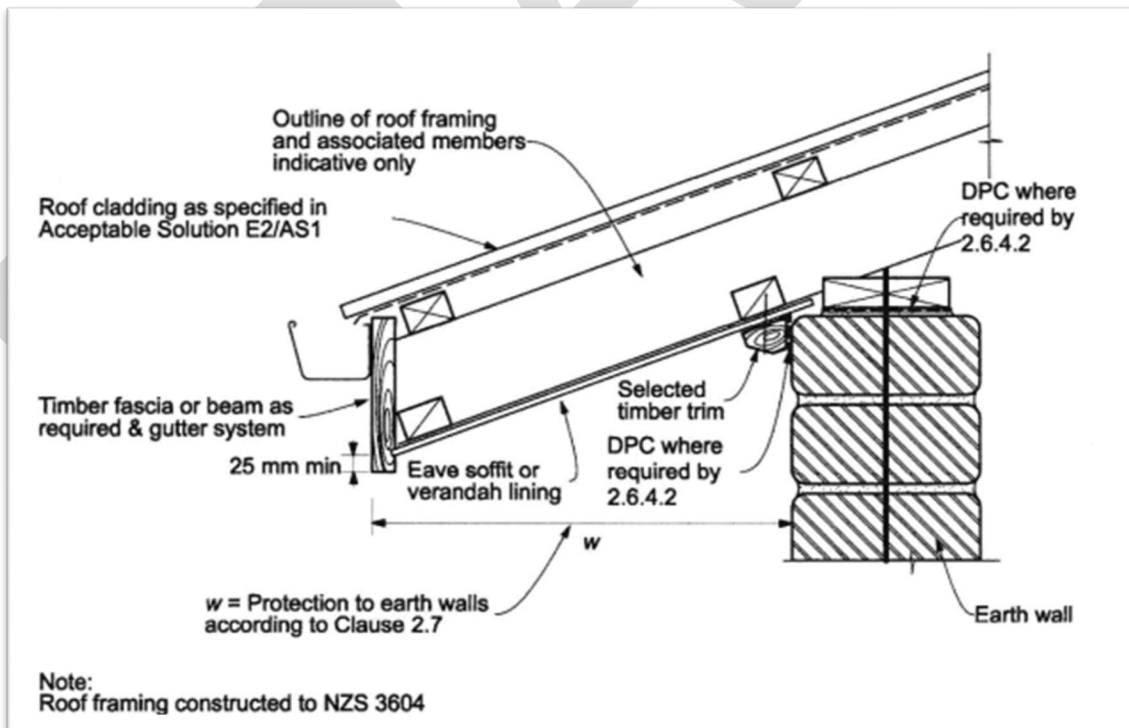

Figure 6.7 – Sloping soffit-to-wall junction

### 6.9 Timber-framed gable wall

The junction between timber-framed gable walls and earth walls shall be constructed as shown in Figure 6.8.

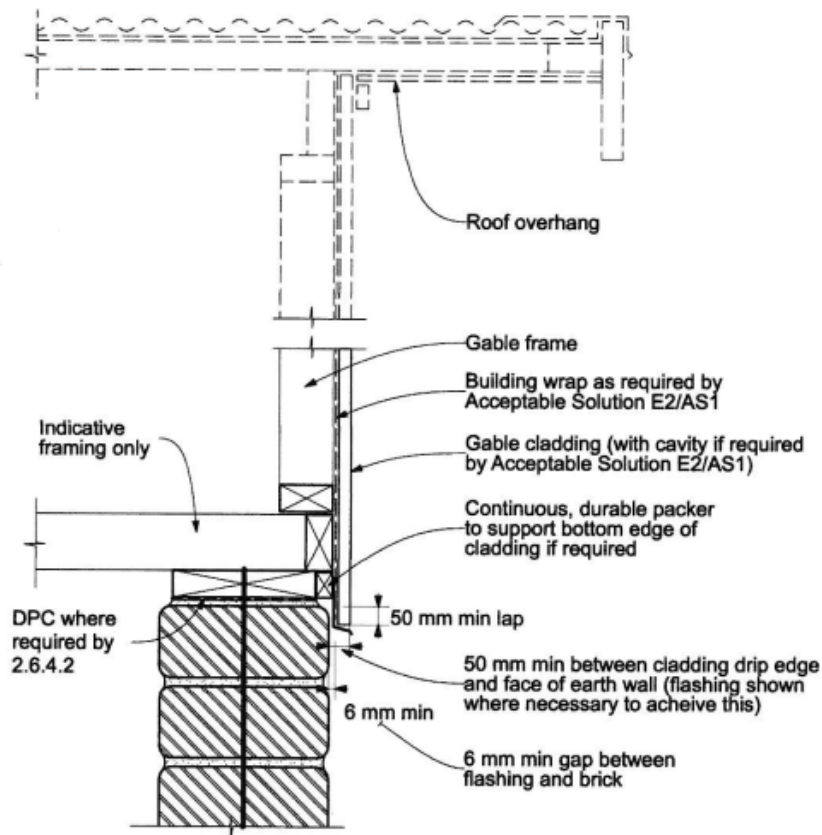

Figure 6.8 – Timber-framed gable to end wall

### 6.10 Reverse soffit eaves

Reverse soffit eaves shall have flashings provided that prevent water from tracking down the face of an earth wall as shown in Figure 6.9.

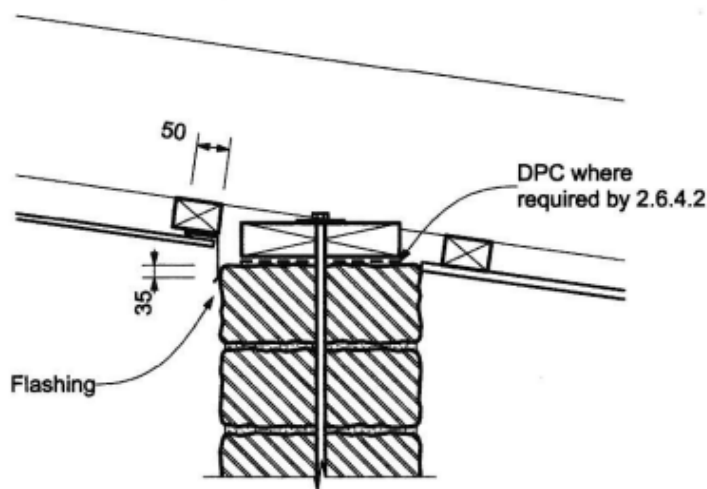

Figure 6.9 – Reverse eaves soffit flashing

## 7 STRUCTURAL DIAPHRAGMS

### 7.1 General

#### 7.1.1

All structural diaphragms supporting earth walls against horizontal forces shall be constructed in accordance with this section.

Diaphragms shall be timber framed with either plywood or plasterboard sheathing.

#### 7.1.2

Timber and plasterboard structural diaphragms complying with 7.2 and 7.3 shall in addition be constructed as follows (see Figures 7.1 to 7.9):

- (a) A diaphragm or part of a diaphragm shall have a length not exceeding two times its width.
- (b) The length and width of a diaphragm as referred to in (a) shall be between supporting walls at right angles to each other.
- (c) The minimum sheet size shall be 1800 × 900 mm except where the building dimensions prevent the use of a complete sheet.
- (d) Each sheet shall be fastened along each edge to boundary members with nails at the centres specified in 7.2.1 and shall also be fastened to every intermediate framing member at 300 mm centres. Joints in sheet material shall be made over supports. Timbers 90 × 45 mm fixed between joists with their top surfaces set to a common level shall be provided as necessary for this purpose.
- (e) Fastenings shall be not less than 10 mm from sheet edges.

#### 7.1.3

Rafter, truss, and ceiling joist sizes shall be in accordance with NZS 3604 unless noted otherwise in this standard.

#### 7.1.4

Rafters, trusses, and ceiling joists shall be solid blocked at all supports and earth walls and ridge lines in accordance with NZS 3604.

#### 7.1.5

Rafter, truss, and ceiling joists splices at supports shall be lapped and nailed or nail plate connected to give a 2 kN axial tension capacity. This includes rafter ridge connections on roofs.

### 7.2 Roof and ceiling diaphragms

#### C7.2

*This clause refers to the slope (if any) of the ceiling, not the roof. However, sloping ceilings are generally at the same slope as the roof above.*

#### 7.2.1

Materials for roof and ceiling diaphragms, sloping or flat, shall be one of the following materials:

- (a) Plywood, not less than 9 mm thick three-ply. The ply shall be nail fixed with 60 × 2.8 mm nails at 150 mm centres into framing member at sheet edges and nail fixed with 60 × 2.8 mm nails at 300 mm centres on intermediate framing members spaced at no more than 600 mm centres.
- (b) High-density fibreglass reinforced plasterboard lining not less than 13 mm thick and having a density of not less than 880 kg/m<sup>3</sup> and screw fixed with 35 mm 6-gauge plasterboard specialist bracing screws at 150 mm centres around the perimeter, 50 mm centres for the first three screws from corners and 300 mm centres infield of the sheet edges on framing members at 600 mm centres.
- (c) Diagonal timber sarking of ex 140 × 19 mm or ex 90 × 19 mm boards of minimum finished thickness of 18 mm that:
  - (i) Are angled at not less than 40° or more than 50° to the ceiling joist, rafter, or ridge line
  - (ii) Are laid in straight parallel lines fitted closely together

- (iii) Are fixed to each ceiling joist, truss, or rafter that they cross
- (iv) Have end joints butted over rafters, trusses, or ceiling joists with end joints in adjacent boards staggered
- (v) Are fixed with two 60 × 2.8 mm nails at each rafter truss or ceiling joist spaced at maximum 900 mm centres
- (vi) Are fixed with two 60 × 2.8 mm nails at ends
- (vii) Are laid to cover the entire area of the diaphragm except for penetrations not exceeding 500 mm square or 550 mm diameter with a total area of 1.0 m<sup>2</sup> or except for openings in accordance with 7.3
- (viii) The edge members to which the sarking is fixed shall be continuous between return walls
- (ix) As an alternative to 60 × 2.8 mm nails, 51 mm long 7-gauge screws may be used.

**C7.2.1**

*For the treatment/ durability requirements of wood-based products refer to NZBC clause B2/AS1.*

*For equivalency of power-driven nails refer to NZS 3604.*

**7.2.2**

Diaphragms shall be fixed to ceiling members including rafters or ceiling battens at the underside of rafters or truss bottom chords. The maximum centre-to centre spacing of these ceiling members shall be 1200 mm.

**7.2.3**

Roof and ceiling diaphragms shall be no steeper than 25° to the horizontal.

**7.2.4**

Roof and ceiling diaphragms not complying with 7.2.1 to 7.2.3 shall be subject to SED.

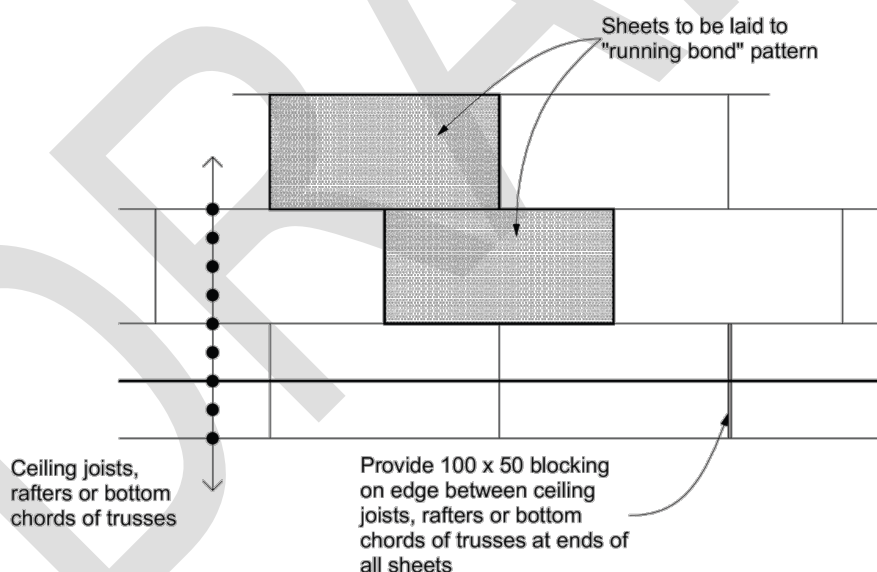

**Figure 7.1 – Diaphragm construction (see 7.1.2)**

**7.2.5 Connection of roof and ceiling diaphragms to earth walls****7.2.5.1**

Roof and ceiling diaphragms shall be connected to either a horizontal bond beam at eaves level or a sloping bond beam at the top of a sloping gable end wall.

7.2.5.2

Roof or ceiling diaphragms shall be connected to a bond beam as shown in Figure 7.2 and Figure 7.4 to Figure 7.7.

Nail plates shall be provided at 900 mm maximum centres to connect the rafter blocking to the timber bond beam.

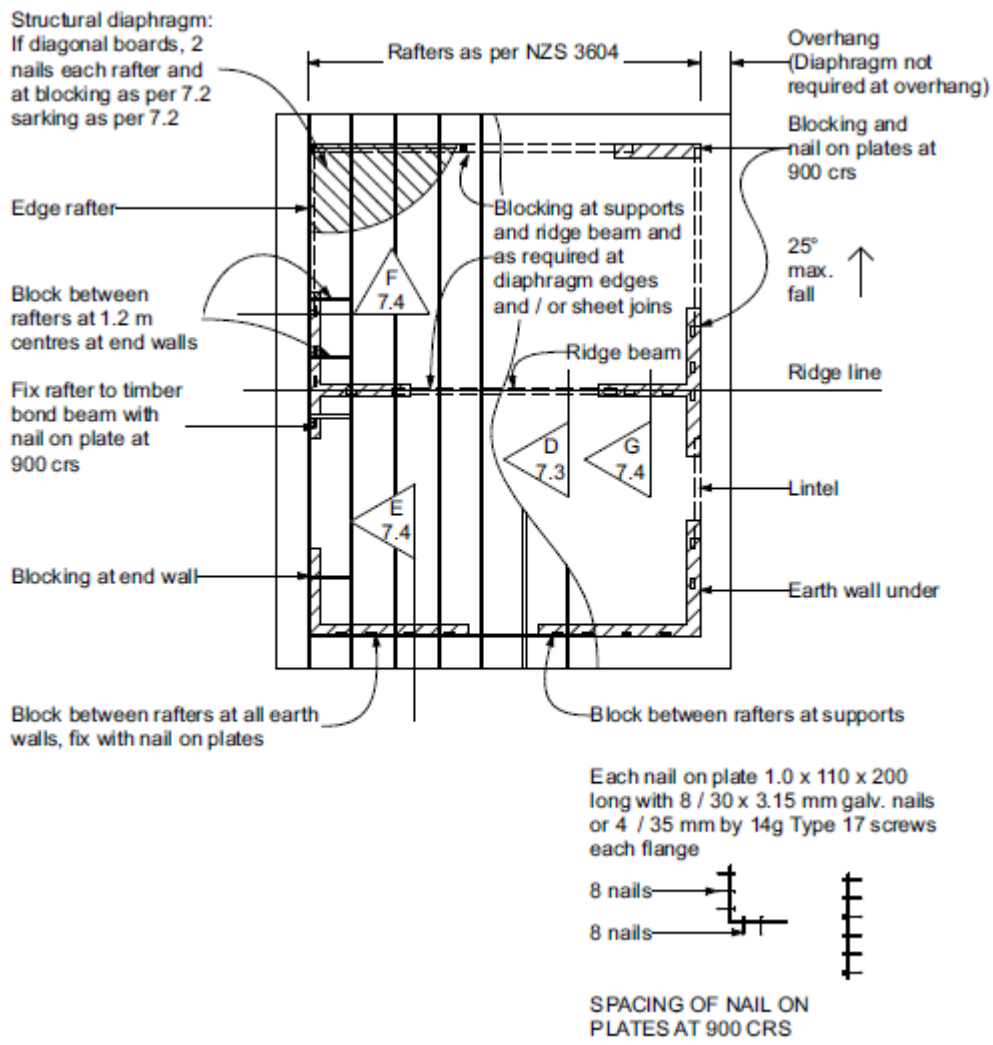

Figure 7.2 – Sloping roof diaphragm

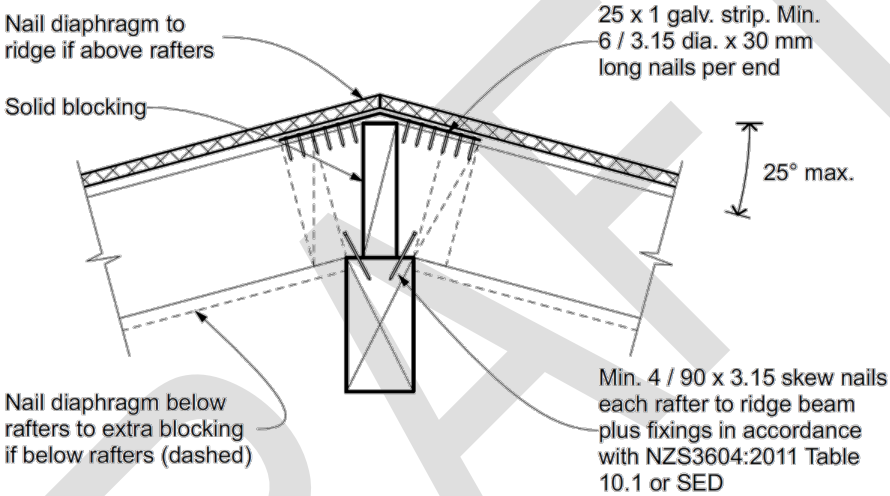

Figure 7.3 – Sloping roof diaphragm – ridge section

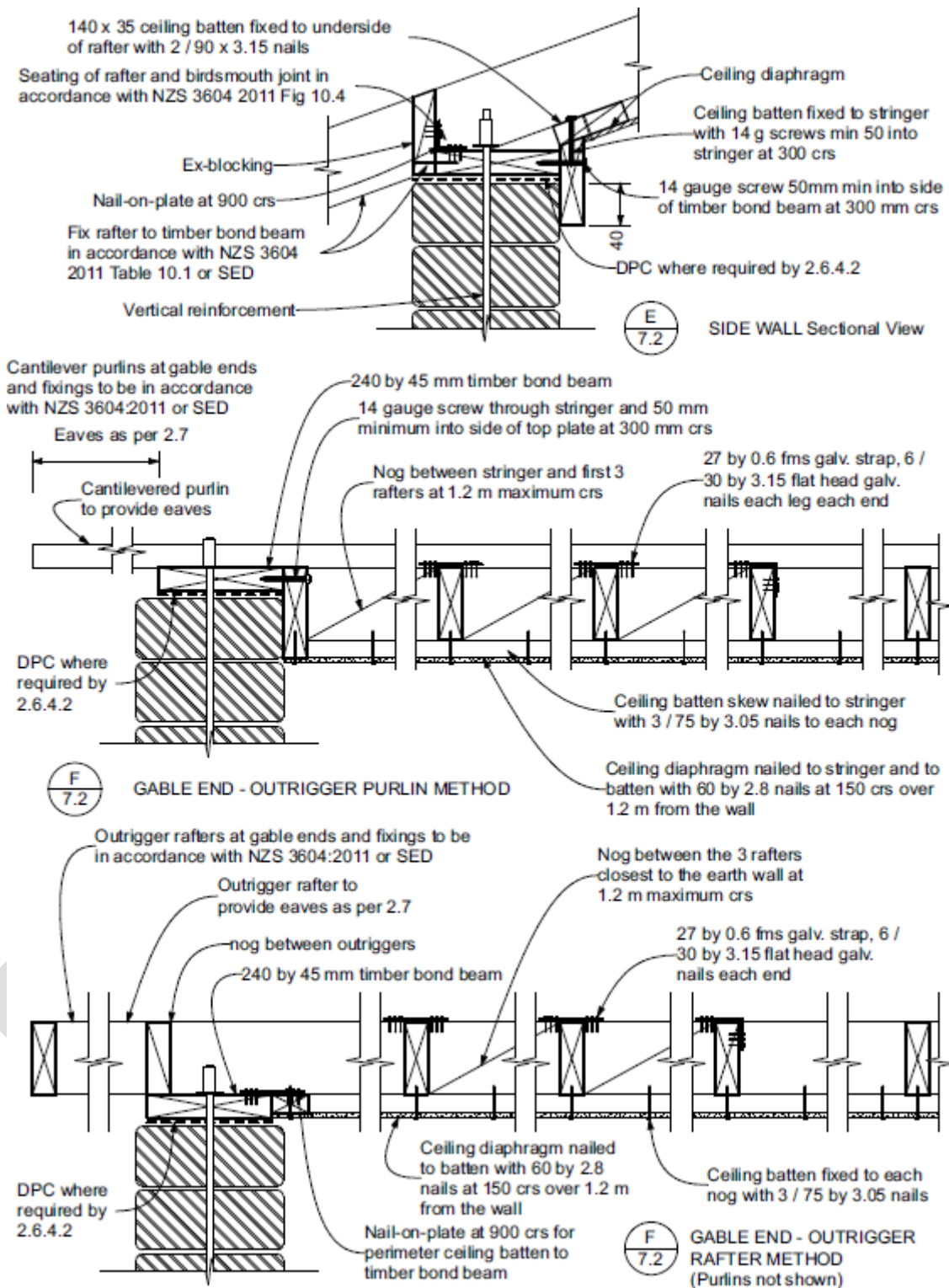
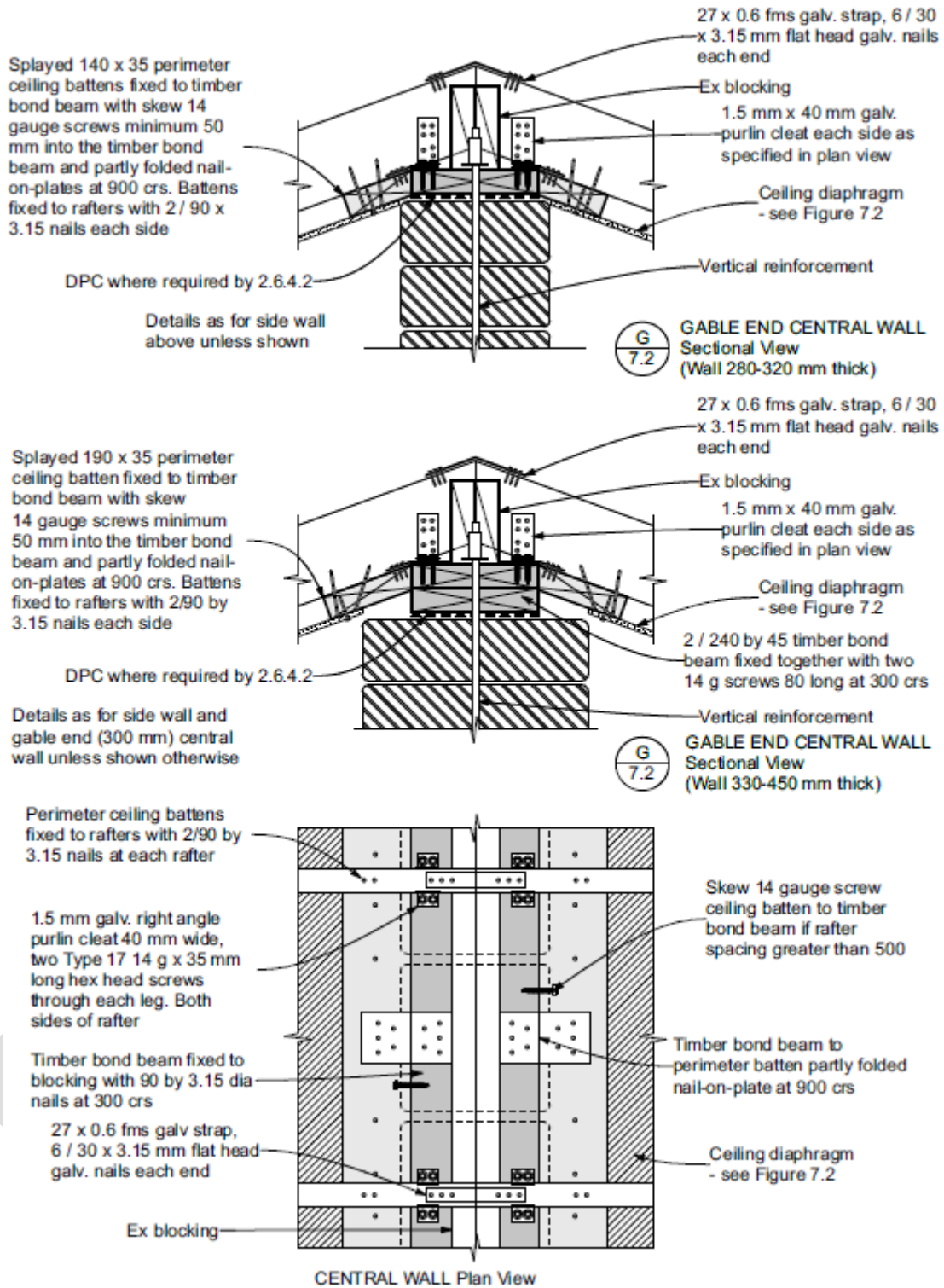
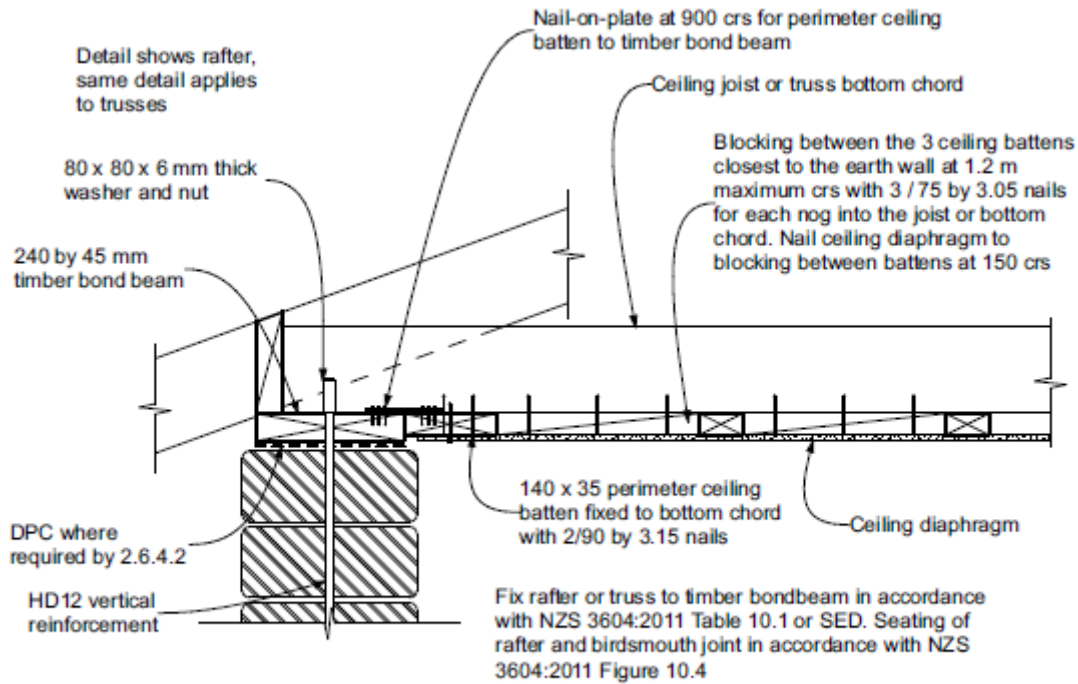

Figure 7.4 – Connection of ceiling diaphragms to side and gable end walls for sloping diaphragms on underside of rafters

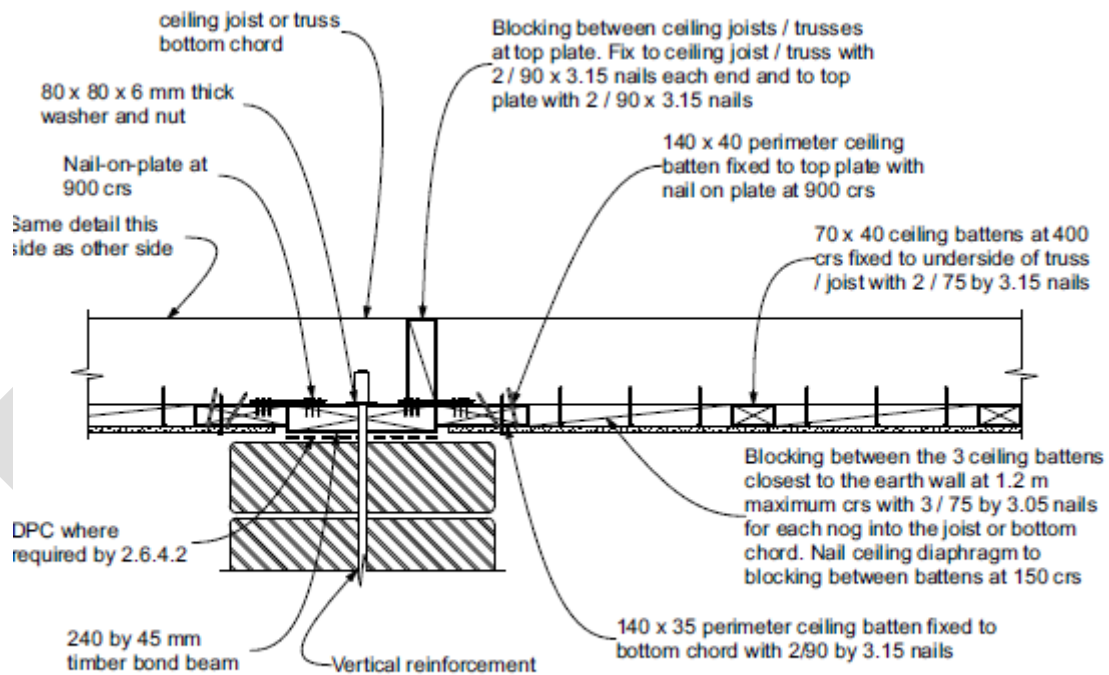



**Figure 7.5 – Connection of ceiling diaphragms to central walls for sloping diaphragms on underside of rafters**



Horizontal ceiling diaphragm - side wall



Horizontal ceiling diaphragm - central wall

Figure 7.6 – Connection of horizontal ceiling diaphragms to side and central earth walls

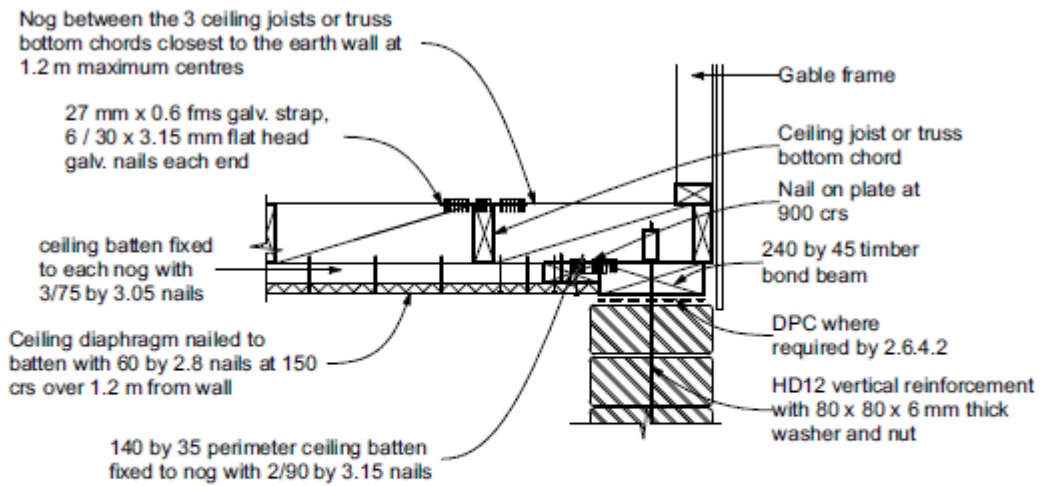

Horizontal ceiling diaphragm - timber gable wall

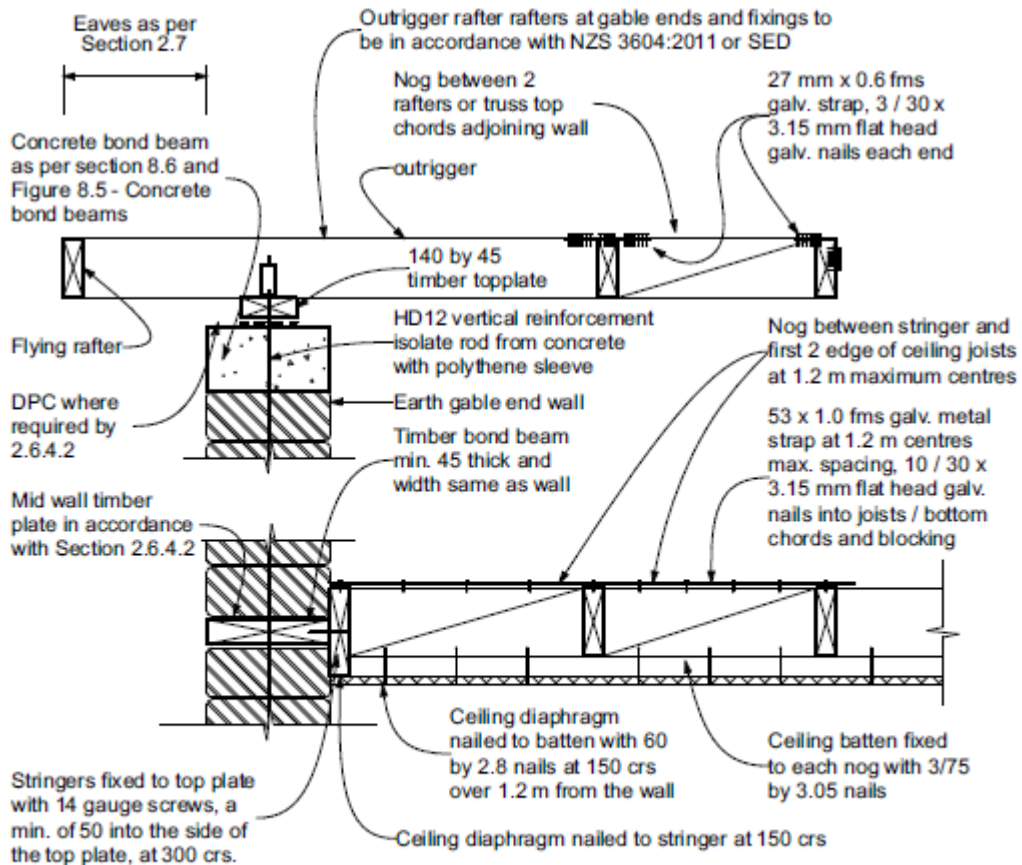

Horizontal ceiling diaphragm - earth gable wall

Figure 7.7 – Connection of horizontal ceiling diaphragms for timber and earth gable walls

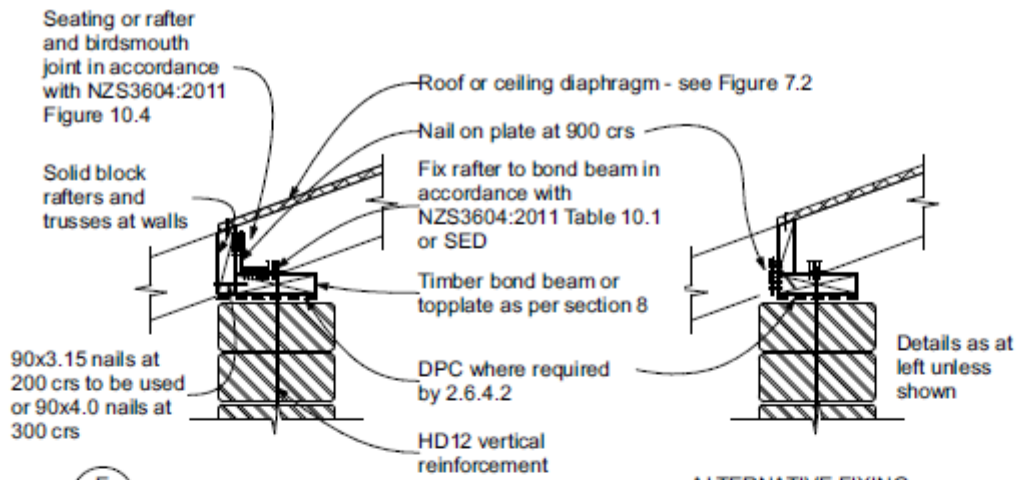

**E**  
7.2

TIMBER BOND BEAM

ALTERNATIVE FIXING TO TIMBER BOND BEAM

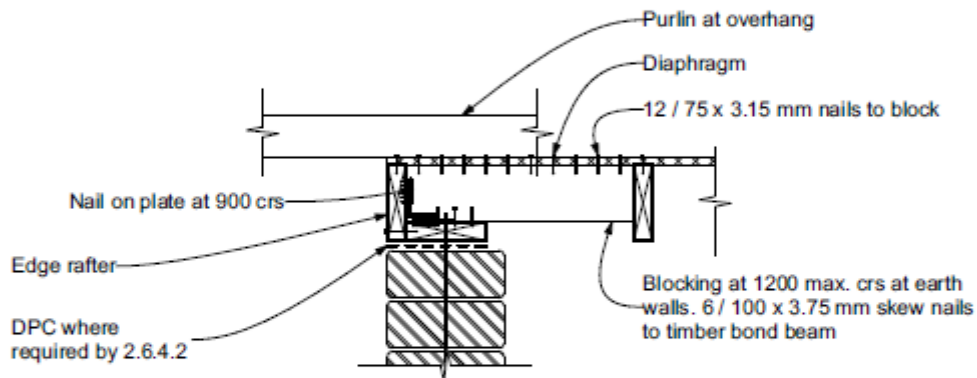

**F**  
7.2

TIMBER BOND BEAM PARALLEL TO RAFTERS AT EARTH WALL

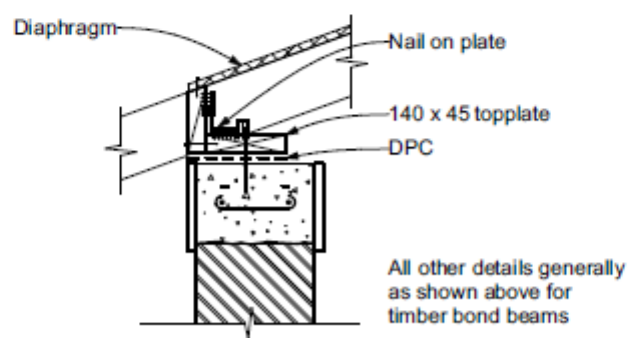

CONCRETE BOND BEAM WITH STRUCTURAL DIAPHRAGM

NOTE -  
These details apply to diaphragms with rafters and trusses

Figure 7.8 Connection of diaphragms to earth walls with roof or ceiling diaphragm on top of rafters

### 7.3 Openings in diaphragms

#### 7.3.1 Timber

##### 7.3.1.1

Continuous boundary members shall be provided to all sides of openings in diaphragms and shall be not less than the rafters or ceiling joists of the diaphragm construction.

##### 7.3.1.2

The dimensions of any single opening in a diaphragm in each of the two principal directions at right angles shall not exceed the following percentages of the respective parallel overall dimension of the diaphragm:

- (a) Where the opening is located wholly within the middle half area of the diaphragm as defined in Figure 7.9: 40%;
- (b) Where the opening is located other than wholly within the middle half area of the diaphragm: 20%;
- (c) In addition, the sum of the areas of all openings in a diaphragm shall not exceed the following percentages of the total area of the diaphragm (inclusive of openings):
  - (i) Where all the openings are located within the middle half area of the diaphragm: 16%
  - (ii) Where any opening is located partially within or outside the middle half area of the diaphragm: 4%.

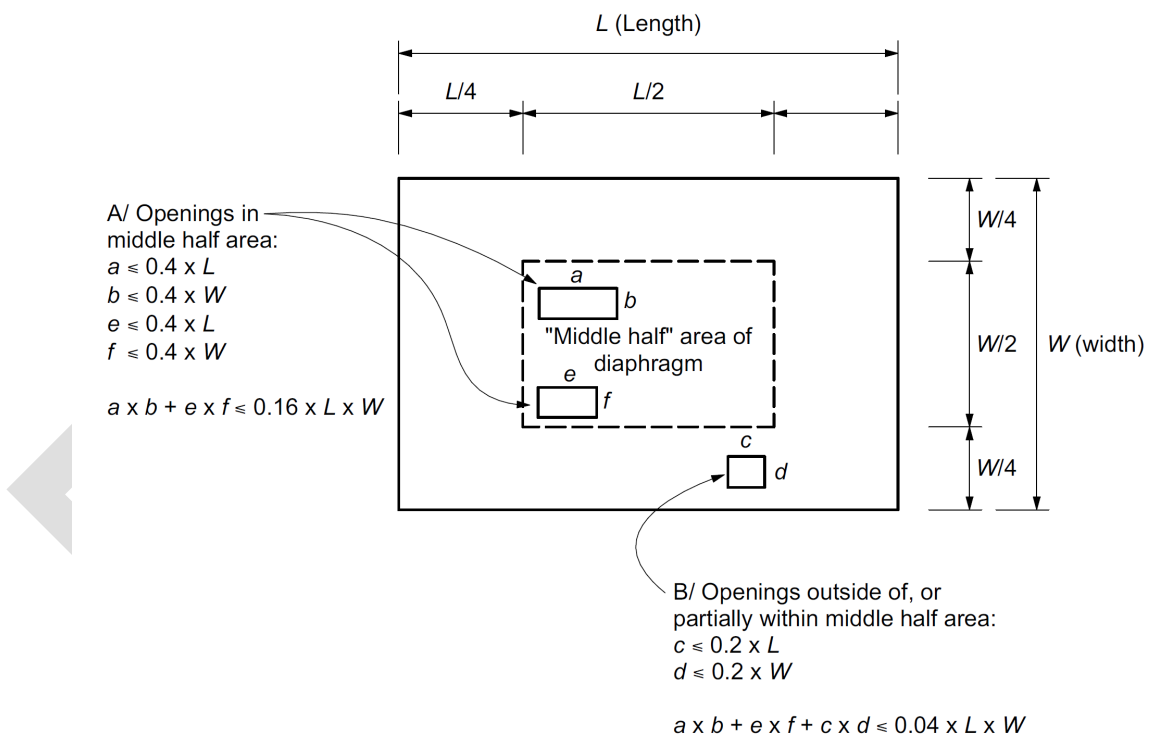

Figure 7.9 Location of opening in diaphragm.

## 8 BOND BEAMS

### 8.1 General

#### 8.1.1

Bond beams shall be provided at the top of all earth walls in order to:

- (a) Assist in supporting lateral loads between adjacent transverse structural walls;
- (b) Provide anchorage of roof members;
- (c) Tie the earth walls together.

#### 8.1.2

The maximum height of earth walls between the footing and bond beam is specified in [Figure 1.1](#).

#### 8.1.3

Timber bond beams shall not be less than 70% of the width of the wall to which they are attached.

The sizes of timber bond beams given here are [actual minimum dried sizes](#) and grade SG8, SG6 or No. 1 framing. If SG6 or No. 1 framing grade is used as provided for in [2.1.8](#), factors are provided for use with the tables that are based on SG8.

#### 8.1.4

The maximum spacing between [the centrelines of](#) transverse bracing walls that connect to the bond beams shall be 6.0 m.

#### 8.1.5

[In earth gable end walls with a skillion roof, there shall be an intermediate horizontal bond beam at the height of the side walls and of the same size as the bond beam of the side walls.](#)

[If there is a horizontal ceiling diaphragm at the height of the side walls, the intermediate member shall be a timber bond beam identical to that of the side walls. Refer to Figure 7.7.](#)

## 8.2 Bond beams with structural diaphragms

### 8.2.1 In earthquake zone 1

Timber or concrete bond beams shall be provided at the top of earth walls as shown in [Table 8.1](#).

[Where there is a ceiling diaphragm, bond beams in either timber or concrete shall be provided at the earth wall diaphragm junction \(plus the top of the earth walls as per 8.6 in the case of gable earth walls continuing above the ceiling diaphragm\).](#)

Bond beams shall be as shown in [Table 8.1](#).

**Table 8.1 – Bond beams with structural diaphragms in all earthquake zones.**

| Bond beam type and minimum size<br>(mm)  | Earth wall application |
|--|------------------------|
| Timber – 240 × 45 (with structural diaphragm only)   | All types              |
| Timber – 190 × 70 (with structural diaphragm only)   | All types              |
| Concrete Type 1 – 224 × 100 with 2/D12 and R6 ties<br>at 400 mm centres  | All types              |
| NOTE – Timber bond beams may need to be wider to comply with 8.1.3<br>Concrete Type 1 bond beam is sufficient for a structural diaphragm |                        |

**C 8.2.1**

*With cob and adobe walls thicker bond beams may be used so that they remain straighter when tightened down as the wall shrinks as it dries.*

**8.2.2**

The connection of the bond beam to the wall and structural diaphragm shall be as shown in the figures of section 7.

**8.3 Bond beams without structural diaphragms****8.3.1**

Where it is not possible to connect earth walls to a structural roof or ceiling diaphragm, the walls shall be laterally supported at the top by a bond beam connected to return walls as shown on Figure 8.1. Such bond beams may be constructed from timber in earthquake zone 1 only. See also 8.6 and 8.7 for gable shaped walls.

**8.3.2**

Return walls shall be provided to provide lateral restraint to bond beams. Such return walls shall contain earth bracing walls in accordance with section 6.3.

**8.3.3**

The maximum length of a bond beam spanning between supporting return walls shall be 6.0 m.

**8.3.4**

Timber bond beams without structural diaphragms shall be continuous between return walls. Concrete bond beams may extend past a return wall by a maximum of 1.2 m, as shown in Figure 8.1.

**8.3.5**

The connections between timber bond beams and either trusses or rafters shall be as shown in Figure 8.2.

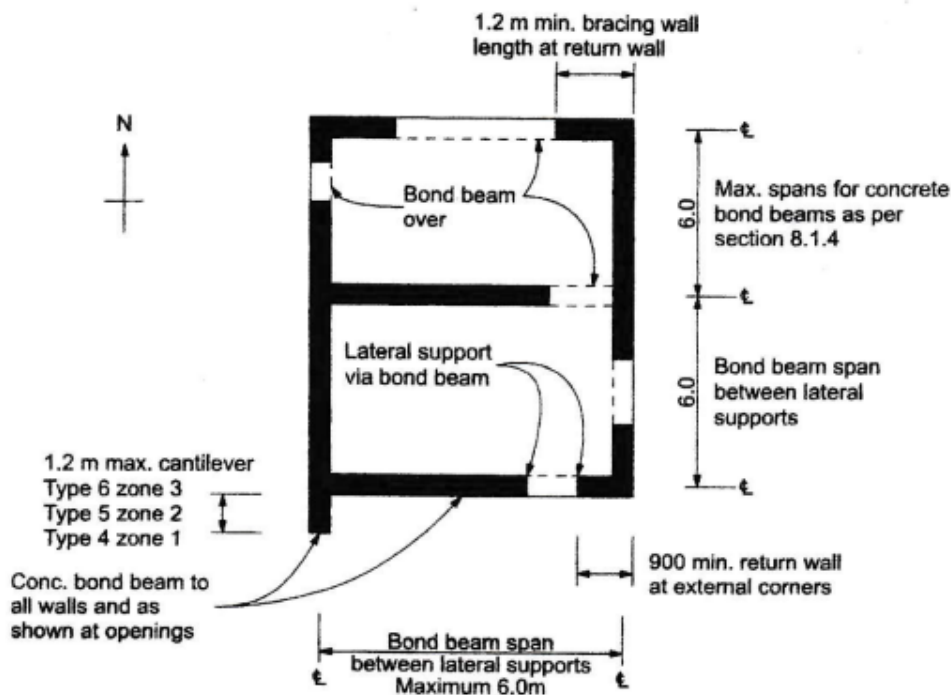

**Figure 8.1 – Layout of earth walls with concrete bond beams and without a structural ceiling diaphragm**

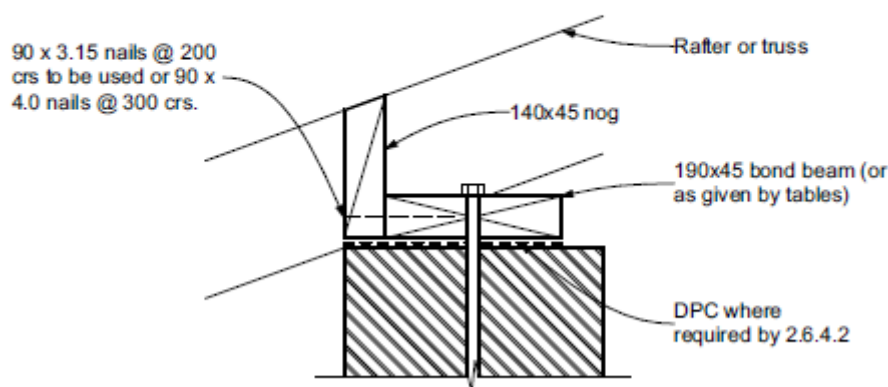
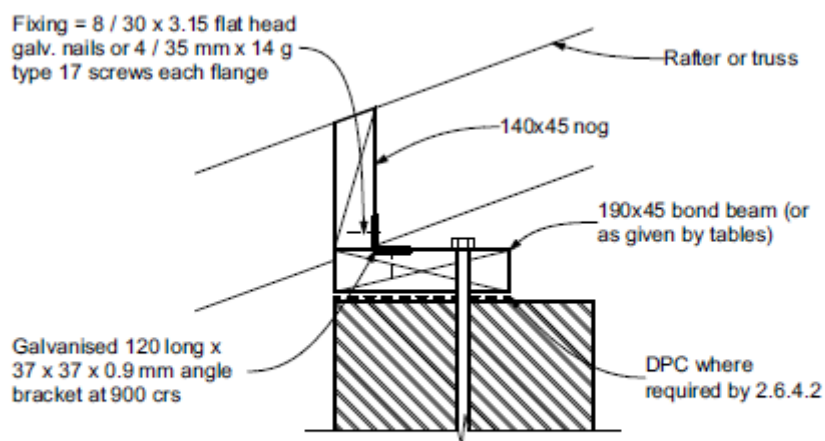

Figure 8.2 – Connection between bond beams and roof without a structural ceiling diaphragm

### 8.3.6 Seismic resistance of bond beams without structural diaphragms

#### 8.3.6.1 General

The selection of a bond beam size depends on seismic zone, seismic subsoil class, wall height, wall thickness, and the earth wall material density, and, in the case of concrete bond beams, bond beam width. A design procedure for both timber and concrete bond beams is provided by 8.3.6.2 to 8.3.7.3. The larger of the sizes for seismic resistance and for wind resistance from these clauses shall be used.

#### 8.3.6.2 Earthquake zone and subsoil class

The selection of both timber and concrete bond beams without structural diaphragms are influenced by the site earthquake and subsoil class factor,  $K_{sz}$ , given by Table 8.4.



**Table 8.2 Bond beams without diaphragms reference span  $L_{ref}$  for earth side walls and earth gable end walls (8 m maximum span trusses)**

| Timber (earthquake zone 1 only) |                        | Concrete (earthquake zones 1-3) |   |                            |
|---------------------------------|------------------------|---------------------------------|---|----------------------------|
| Reference span<br>$L_{ref}$ (m) | Bond beam size<br>(mm) | Reference span<br>$L_{ref}$ (m) | Concrete<br>bond beam<br>type (see<br>Figure 8.5) | Bond beam<br>Width<br>(mm) |
| 2.10 m                          | 190 x 45 mm            | 2.52 m                          | 1   | 280                        |
| 2.62                            | 190 x 70               | 3.23                            | 2   | 280                        |
| 2.57                            | 190 x 90               | 3.30                            | 3   | 280<br>280                 |
| 2.65                            | 240 x 45               | 3.34                            | 4   | 280                        |
| 3.31                            | 240 x 70               | 4.08                            | 5   | 280                        |
| 3.75                            | 240 x 90               | 3.56                            | 1   | 430                        |
| 3.2                             | 290 x 45               | 4.63                            | 2   | 430                        |
| 4.16                            | 290 x 70               | 4.70                            | 3   | 430                        |
| 4.51                            | 2/ 290 x 45            | 4.73                            | 4   | 430                        |
| 6.00                            | 3/ 290 x 45            | 5.85                            | 5   | 430                        |
|                                 |                        | 7.32                            | 6   | 430                        |
|                                 |                        | 8.20                            | 7   | 430                        |

**NOTE:**

- (1) Timber bond beams may need to be wider to comply with 8.1.3.
- (2) Timber bond beams without a diaphragm are limited by 8.3.1 and shall only be used in seismic zone 1.
- (3)  $L_{ref}$  for gable end walls (whether earth or timber) is the same as  $L_{ref}$  for side walls.
- (4) The internal rafters or trusses at a gable end wall shall span parallel to the gable end wall.
- (5)  $L_{all}$  maximum is 6.0 m for any timber bond beam.
- (6) The 280 mm and 430 mm concrete bond beams may each be reduced by 56 mm width for 50 mm polystyrene exterior insulation protected by 6mm fibre-cement sheet.
- (7) The leaves of double or triple bond beams shall be nailed together with pairs of 90 mm x 3.15 mm nails at 150 mm centres.

**Table 8.3– Earthquake and subsoil class factor,  $K_{sz}$**

| Subsoil class | Earthquake and subsoil class factor, $K_{sz}$ |      |      |
|---------------|---|------|------|
|               | Earthquake zone                               |      |      |
|               | 1   | 2    | 3m   |
| A and B       | 1.0   | 0.82 | 0.66 |
| C             | 0.9   | 0.73 | 0.59 |
| D and E       | 0.80  | 0.65 | 0.52 |

NOTE – Timber bond beams without a diaphragm only in earthquake zone 1

**8.3.6.3 Bond beam size**

Timber bond beams are to be in accordance with 2.1.8 and concrete bond beams in accordance with 2.1.2. Bond beam size shall be determined by selecting a beam size that has an allowable span  $L_{all}$  that is equal to or greater than given by Equation 8-1.

The bond beam size is selected using table 8.3 and equation 8.1 and from the factors given below and in Tables 8.4 and 8.5 for the following situations:

- (a) For earth side walls [defined as an external wall that does not contain a gable] and is generally horizontal or may be raking at less than ten degrees (approximately 1:6)
- (b) Gable end walls

$$L_{all} = L_{ref} \times K_{sz} \times K_{ed} \times K_w \times K_h \times K_g \quad (\text{Eq.8.1})$$

Where:

$L_{all}$  = The allowed length of the timber bond beam between supports (m) (measured between the centrelines of the orthogonal bracing walls)

$L_{ref}$  = The reference length of the timber bond beam from Table 8.3

$K_{sz}$  = The earthquake and soil class factor from table 8.4  
 $K_{ed}$  = Earth wall material density factor, which:  
 = 1.00 for earth wall material density from 1400 kg/m<sup>3</sup> to 2200 kg/m<sup>3</sup>  
 = 1.18 for earth wall material density from 800 kg/m<sup>3</sup> up to 1400 kg/m<sup>3</sup>

$K_{cw}$  = Beam width factor  
 = 1.0 for 450 wide walls  
 = 1.07 for 350 wide walls  
 = 1.18 for 280 wide walls

$K_g$  = Timber grade factor:  
 = 0.85 where SG6 or No. 1 framing grade is used as provided for in 2.1.8  
 = 1.0 where SG8 is used  
 = 1.0 for concrete bond beams

$K_h$  = wall height factor for side walls and timber gables  
 = 1.0 for all earth gable walls

For side walls and timber gable walls = 1.0 for 3.0 m high earth walls  
 = 1.04 for 2.7 m high earth walls  
 = 1.08 for 2.4 m high earth walls

### C 8.3.6.3

Equation 8-1 takes account of the service requirements for the bond beam of the loading situation, the required length of the bond beam, seismic soil class and earthquake zone of the site, and the earth wall density, wall height, wall width, and timber grade.

$L_{ref}$  is the strength governed bond beam for a 450 mm wide, 22 kN/m<sup>3</sup>, 3.05 m high wall in earthquake zone 1 on class A and B subsoils.

## 8.3.7 Wind resistance of bond beams without structural diaphragms

For wind, concrete bond beams sizes are given by Table 8.6. Concrete bond beams to be in accordance with 2.1.2.

### 8.3.7.1 Strength requirements

The strength of bond beams for both side walls and gable end depends on the design wind speed for the building obtained from NZS 3604. The larger of the sizes for seismic resistance from 8.3.6 and for wind resistance from 8.3.7 shall be used.

**8.3.7.2 Timber bond beams for wind**

For wind, timber bond beam sizes are given by [Table 8.5](#). Timber bond beams are to be in accordance with [8.3](#). Timber bond beams without a diaphragm are limited by [8.1.3](#).

**Table 8.4 Timber bond beam for wind resistance**

| SG8 Size (mm) | Span of bond beam (m)   |      |      |      |
|---------------|-------------------------|------|------|------|
|               | Wind zone from NZS 3604 |      |      |      |
|               | VH                      | H    | M    | L    |
| 190 × 45      | 3.40                    | 3.87 | 4.59 | 5.30 |
| 190 × 70      | 4.24                    | 4.84 | 5.73 | 6.0  |
| 240 × 45      | 4.29                    | 4.90 | 5.80 | 6.0  |
| 190 × 90      | 4.80                    | 5.48 | 6.0  | 6.0  |
| 200 × 45      | 5.17                    | 5.90 | 6.0  | 6.0  |
| 240 × 70      | 5.36                    | 6.0  | 6.0  | 6.0  |
| 240 × 90      | 6.0                     | 6.0  | 6.0  | 6.0  |

NOTES:.....

(1) In the shaded cells the maximum span is limited by 8.3.3 to 6.0 m.  
 (2) The above spans shall be multiplied by 0.85 if SG6 or No. 1 framing grade is used instead of SG8 as provided for in 2.1.8.

**8.3.7.3 Concrete bond beams for wind**

For concrete bond beams sizes are given by [Table 8.6](#) Concrete bond beams to be in accordance with [2.1.2](#).

**Table 8.5 Concrete bond beam for wind**

| Concrete bond beam type | Span of bond beam (m)   |      |      |     |
|-------------------------|-------------------------|------|------|-----|
|                         | Wind zone from NZS 3604 |      |      |     |
|                         | VH                      | H    | M    | L   |
| 1                       | 4.07                    | 4.64 | 5.49 | 6.0 |
| 2                       | 5.21                    | 5.94 | 6.0  | 6.0 |
| 3                       | 5.33                    | 6.0  | 6.0  | 6.0 |
| 4                       | 5.39                    | 6.0  | 6.0  | 6.0 |
| 5                       | 6.0                     | 6.0  | 6.0  | 6.0 |

NOTE – In the shaded cells the maximum span is limited by 8.3.3 to 6.0 m.

**8.4 Intersection of timber bond beams**

**8.4.1 Intersections and joints between timber bond beams**

Intersections and joints between timber bond beams shall be fixed as shown in:

- (a) [Figure 8.3](#) for timber bond beams with structural diaphragms.
- (b) [Figure 8.4](#) for timber bond beams without structural diaphragms.

8.4.2

For timber bond beams without structural diaphragms, joints in the bond beam shall be only at the corners and intersections of walls.

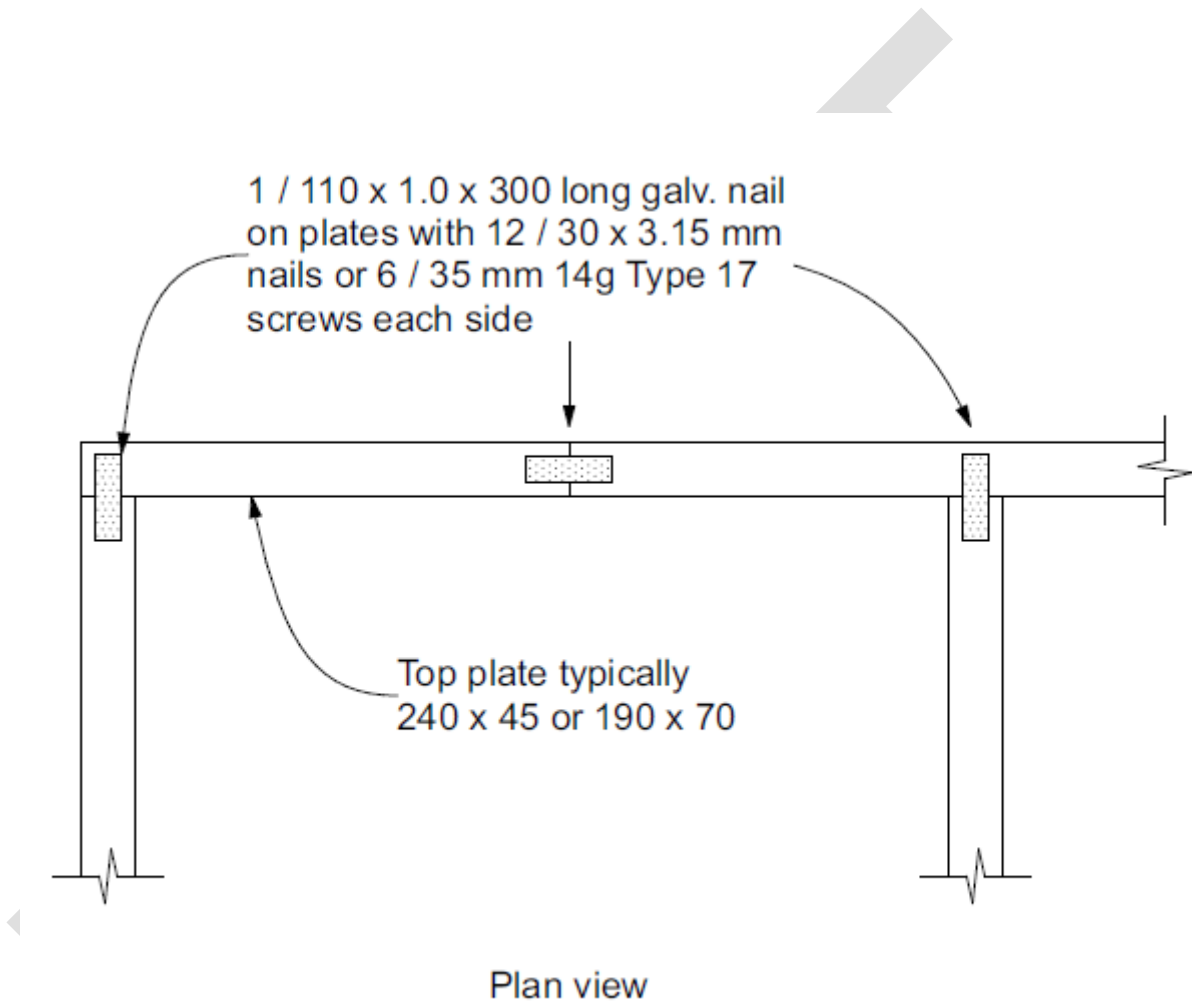

Figure 8.3 – Connection of timber bond beams or top plates with structural diaphragms (plan)

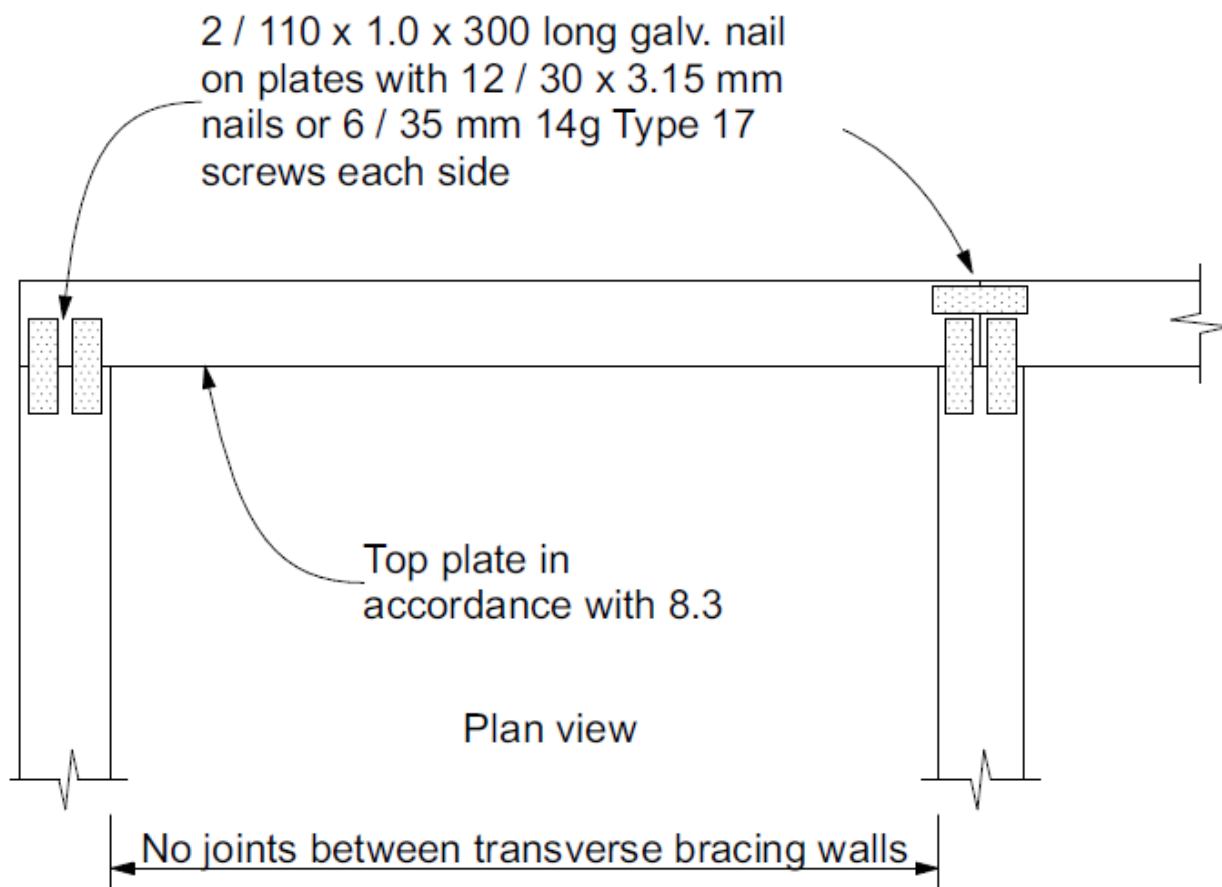

Figure 8.4 – Connection of timber bond beams or top plates without structural diaphragms (plan)

## 8.5 Concrete bond beam details

### 8.5.1 Laps in reinforcement of concrete bond beams

Laps in reinforcement of concrete bond beams shall be 40 times the bar diameter for Grade 300 reinforcing and 60 times the diameter for Grade 500 reinforcing and as shown in Figure 5.5.

### 8.5.2 Size of reinforcement of concrete bond beams

The size and reinforcement and cover of concrete bond beams shall be as shown in Figure 8.5.

Where there is a structural diaphragm, the R6 ties in concrete bond beams shall be at 400 mm centres.

Where there is no structural diaphragm, the R6 ties in concrete bond beams shall be at 200 mm centres.

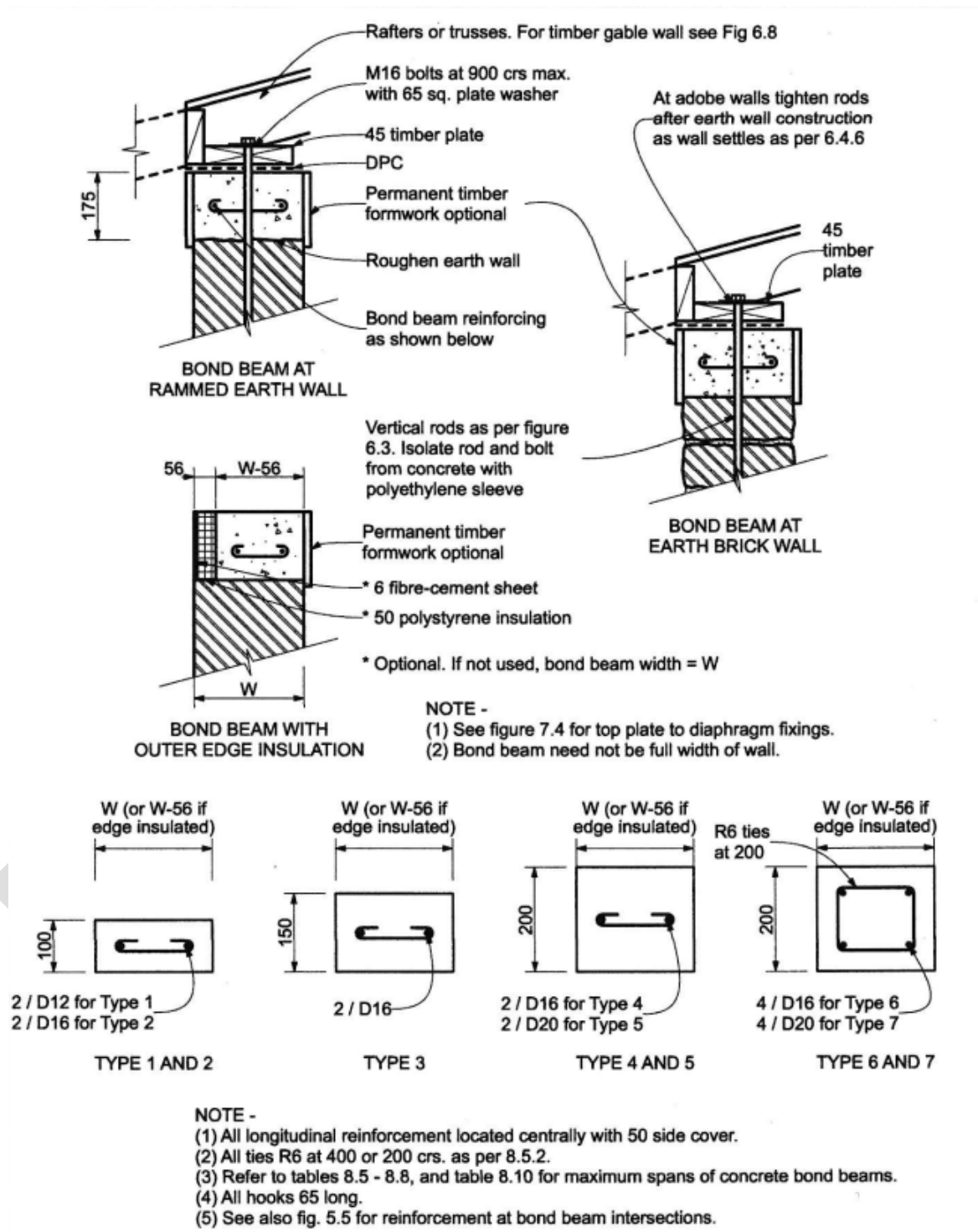
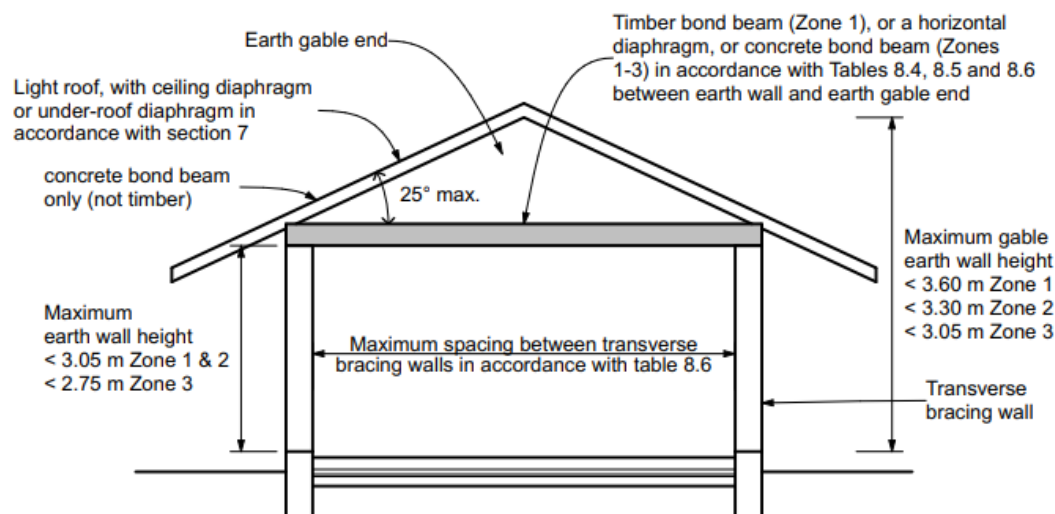

Figure 8.5 – Concrete bond beams



**Figure 8.6 – Bond beam for gable end walls above earth walls**

### 8.5.3 Intersection of concrete bond beams

Horizontal reinforcement at the corners and intersections of bond beams shall be continuous, or provided with L bars, or U bars for T intersections, as shown in Figure 5.5 with minimum lap lengths and bar bend radii as specified below.

Minimum lap lengths are:

- (a) Grade 300 reinforcing, 40 times the bar diameter.
- (b) Grade 500 reinforcing, 60 times the bar diameter.
- (c) Where a smaller bar laps a larger bar, the number of smaller bar diameters shall be used for the lap length.
- (d) Similarly, if a lower strength bar laps one of higher strength, the number of bar diameters of the weaker bar shall be used.

Minimum bar bend radius shall be five times the bar diameter. The minimum diameter of the bend is measured on the inside of the bar.

Grade 500 bars may only be re-bent once during construction.

## 8.6 Gable-shaped earth walls

A raking concrete bond beam shall be provided to top of every gable-shaped earth wall and shall be connected to and be continuous with other adjoining concrete bond beams. The size of the raking bond beam shall be determined in accordance with 8.3.6.3. The maximum height of gable shaped earth walls shall be as per Figure 1.1A.

### 8.6.1 Height limitations for earth wall gable ends

An intermediate bond beam at the same height of the top of the adjacent side walls is not required for the gable shaped earth wall, where there is a flat ceiling diaphragm at the level of the adjacent side walls in which case the diaphragm shall be attached to the gable end earth wall as shown in Figure 7.7.

## 8.7 Timber gable end walls above earth walls

### 8.7.1 Earthquake loading

Where there are timber gable ends above earth walls as shown in [Figure 6.8](#) one of the following shall be provided:

- (a) A [horizontal timber bond beam](#) or [horizontal concrete bond beam](#) with a flat ceiling diaphragm in accordance with section 7; or
- (b) A concrete or timber bond beam without a structural diaphragm in accordance with [Figure 8.6](#) and [clauses 8.3 and 8.4](#);
- (c) A timber bond beam between the top of the earth wall and the timber gable end, spanning between the adjacent side walls, and with a roof diaphragm not steeper than  $25^\circ$  as shown in [Figure 8.6](#). The size of the timber bond beam to be in accordance with [Tables 8.1 and 8.4](#).

### 8.7.2 Intersections and joints between timber bond beams

Intersections and joints between timber bond beams between timber gable ends and earth walls shall be as shown in [Figure 8.3](#) and [Figure 8.4](#).

There shall be no joints in the straight bond beam section between transverse bracing walls.



## 9 LINTELS

### 9.1 General

#### 9.1.1 Scope

Lintels shall be used over all openings and shall be constructed of timber in accordance with 9.2 or of concrete in accordance with 9.3.

#### C 9.1.1

*The lintel details provided in this section make provision for the drying shrinkage of earth walls.*

#### 9.1.2 Limitations

The designs for lintels supporting roofs provided here are for lintels with a loaded dimension of up to 5.53 m. Where the loaded dimension is greater than this, SED is required.

#### C9.1.2

*The maximum loaded dimension of 5.53 m results where half the maximum roof span = 4 m plus half the maximum verandah span 1.53 m.*

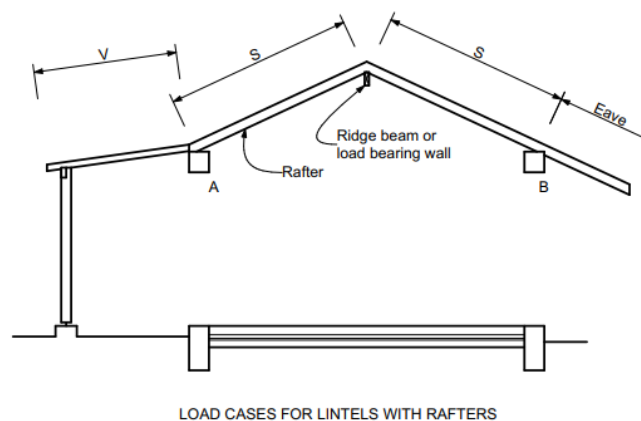
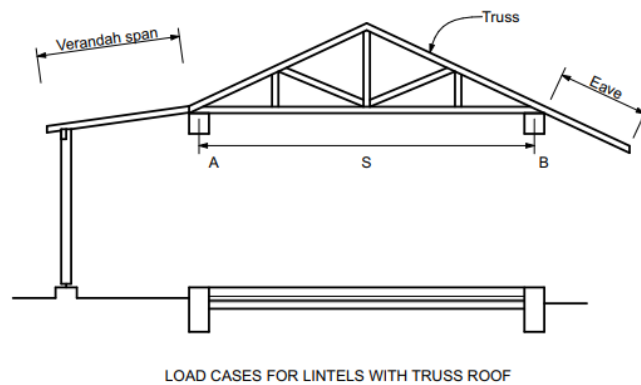

Load on lintel A =  $S/2 + 1/2$  verandah span  
 Load on lintel B =  $S/2 +$  eave length

Figure 9.1 – Load cases for lintels

## 9.2 Timber lintels

### 9.2.1

Lintels supporting earth walls up to 1.2 m high and supporting trusses, purlins, or rafters are to be in accordance with this section.

For spans up to 1.5 m, timber lintels shall be seated a minimum of 300 mm on the full earth wall width on either side of the opening.

Lintels with a clear span of more than 1.5 m shall be seated the full wall width a minimum 450 mm on the earth walls.

Timber lintels narrower than the wall width shall bear on a 50 minimum thickness timber block the same width as the wall as shown in Figure 9.2. For splayed reveals greater than 100 mm there is to be a 300 mm bearing at the widest part of the opening (450 mm bearing for spans above 1.5 m).

Lintels shall not be nail fixed directly to a supporting timber block if present.

#### **C 9.2.1**

*Solid timber lintels or box beams the full width of the wall may bear directly on the earth wall.*

*Not nailing to the supporting block reduces the risk of cracking the wall.*

### 9.2.2

Timber lintels supporting timber-framed roof or timber gable ends and roof only shall be in accordance with NZS 3604 and as shown in Figure 9.2.

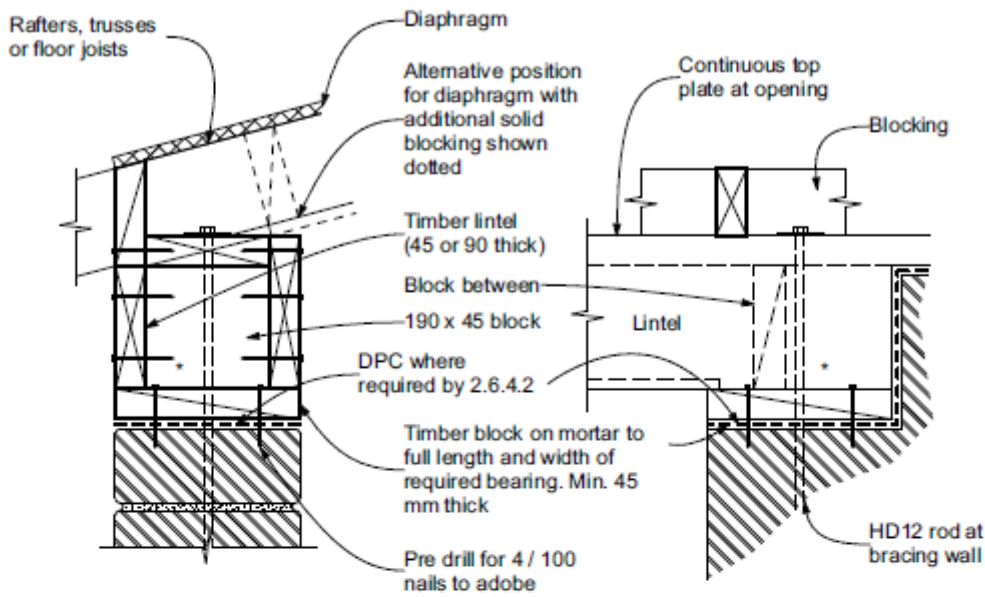

SECTION AT SUPPORT

ELEVATION AT LINTEL SUPPORT

\* NOTE- Do not nail lintels to block under (or wall shrinkage may crack bricks).

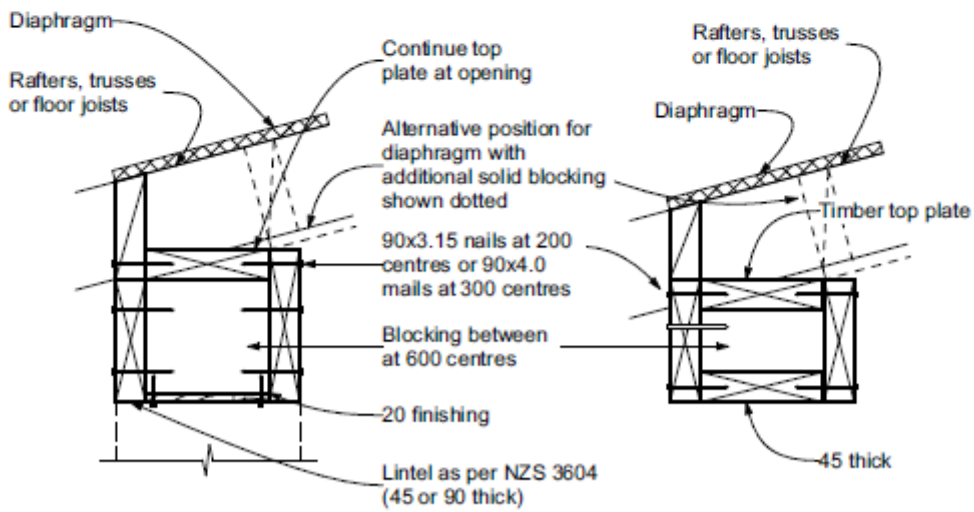

SECTION AT LINTEL

BOX BEAM LINTEL

Figure 9.2 – Timber lintels supporting timber framing above

9.2.3

Timber lintels with earth over them (earth gable end walls or side walls) shall be as shown on [Figures 9.3 and 9.4](#). Timber lintels are to be fabricated from multiple leaves of 45 mm thick timber on edge nail laminated together with nails. The lintel may be blocked out with additional narrower pieces towards the centre of the cross section to make up the full width of the earth wall and provide full width bearing surfaces top and bottom. The timber lintel sizes are given by:

- (a) [Table 9.1](#) for lintels supporting side and gable walls with earth wall over; or
- (b) [Table 9.2](#) for lintels supporting side and gable end walls with timber framing over.

Timber lintels shall be supported at mid-span both during construction and for one month after construction of an earth wall above.

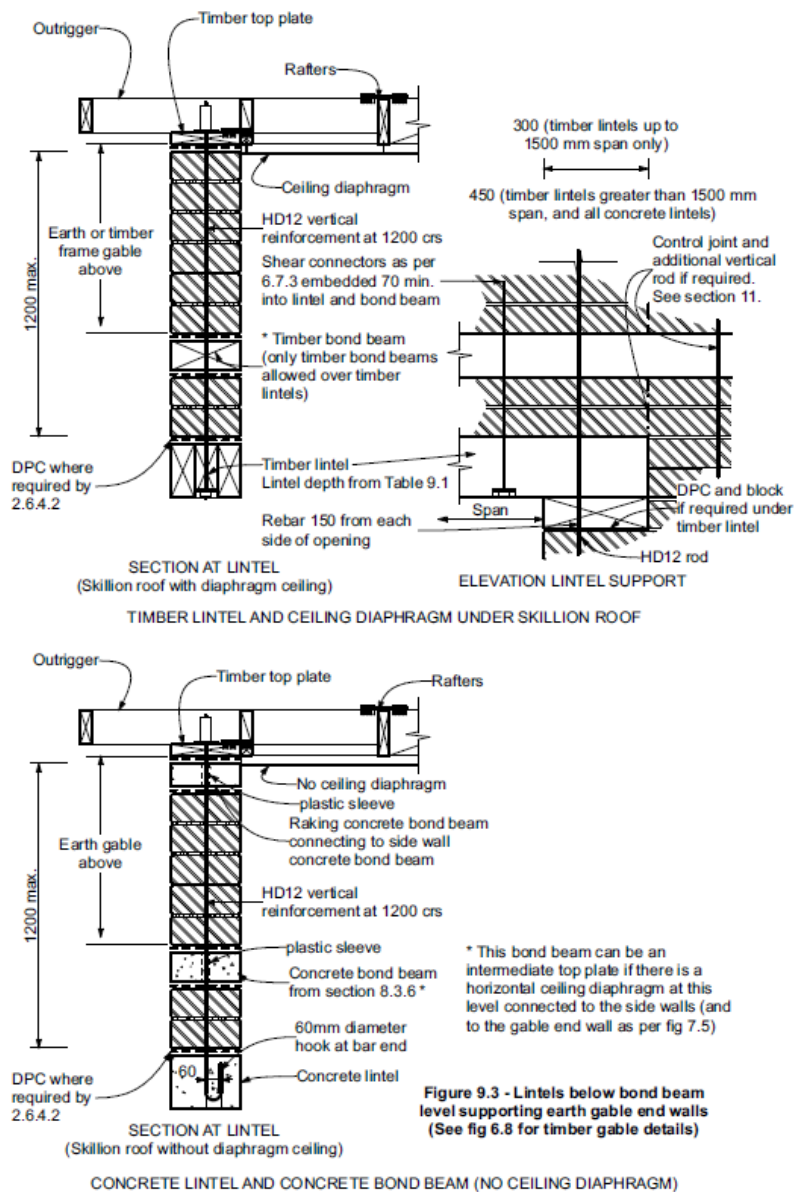

**Figure 9.3 – Lintels below bond beam level supporting earth gable end walls (See fig 6.8 for timber gable details)**

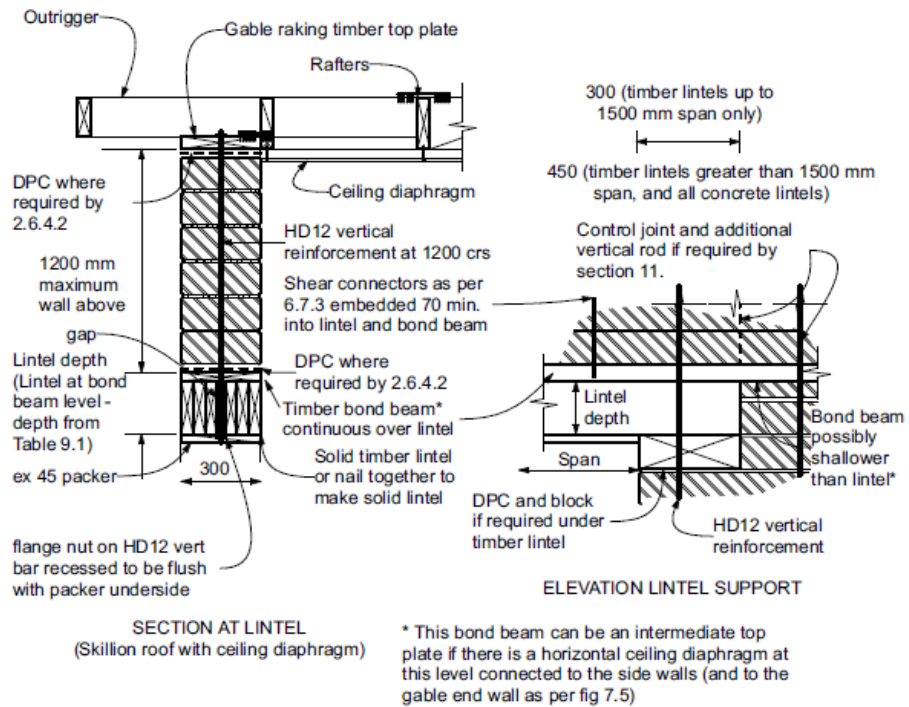

Figure 9.4 – Timber lintel at bond beam level supporting earth gable end walls (see fig 6.8 for timber gable details)

Table 9.1 – Side wall and earth gable: timber lintels with ground snow loads up to 2.0 kPa. 1.2m maximum earth wall over lintel

| Lintel clear opening (m) | Lintel size (mm)       |            |            |
|--------------------------|------------------------|------------|------------|
|                          | Ground snow load (kPa) |            |            |
|                          | ≤ 1.0                  | <1.0 ≤ 1.5 | <1.5 ≤ 2.0 |
| 0.6                      | 2/190 x 45             | 2/190 x 45 | 2/190 x 45 |
| 0.9                      | 3/190 x 45             | 3/190 x 45 | 3/190 x 45 |
| 1.2                      | 4/190 x 45             | 4/190 x 45 | 4/190 x 45 |
| 1.5                      | 4/190 x 45             | 2/290 x 45 | 2/290 x 45 |
| 1.8                      | 2/290 x 45             | 3/290 x 45 | 3/290 x 45 |
| 2.1                      | 3/290 x 45             | 3/290 x 45 | 3/290 x 45 |
| 2.4                      | 4/290 x 45             | 4/290 x 45 | 4/290 x 45 |
| 2.7                      | 5/290 x 45             | 5/290 x 45 | 5/290 x 45 |
| 3.0                      | 7/290 x 45             | 7/290 x 45 | 7/290 x 45 |

NOTE –

- (1) For rafter/truss span up to 8.0 m, spacing up to 1.2 m
- (2) The permitted clear opening spans shall be multiplied by 0.71 where SG6 or No. 1 framing grade as provided for in 2.1.8 is used in place of SG8.
- (3) Seating on lintel for spans over 1.5 m to be 450 mm long by wall width. Seating 300 mm for spans less than 1.5 m
- (4) Rafters/truss to span parallel to gable walls

**Table 9.2 – Side wall and timber gable end wall timber lintels with ground snow loads up to 2.0 kPa with timber head framing**

| Lintel clear opening<br>(m) | Lintel size<br>(mm)       |                 |                 |
|-----------------------------|---------------------------|-----------------|-----------------|
|                             | Ground snow load<br>(kPa) |                 |                 |
|                             | $\leq 1.0$                | $<1.0 \leq 1.5$ | $<1.5 \leq 2.0$ |
| 0.6                         | 2/140 x 45                | 2/140 x 45      | 2/190 x 45      |
| 0.9                         | 2/140 x 45                | 2/190 x 45      | 2/190 x 45      |
| 1.2                         | 2/190 x 45                | 2/190 x 45      | 2/190 x 45      |
| 1.5                         | 2/190 x 45                | 3/190 x 45      | 3/190 x 45      |
| 1.8                         | 3/190 x 45                | 4/190 x 45      | 4/190 x 45      |
| 2.1                         | 4/190 x 45                | 4/190 x 45      | 2/290 x 45      |
| 2.4                         | 4/190 x 45                | 4/190 x 45      | 3/290 x 45      |
| 2.7                         | 2/290 x 45                | 3/290 x 45      | 3/290 x 45      |
| 3                           | 3/290 x 45                | 3/290 x 45      | 3/290 x 45      |

NOTE –

(1) For rafter/truss span up to 8.0 m, spacing up to 1.2 m

(2) The permitted clear opening spans shall be multiplied by 0.71 where SG6 or No. 1 framing grade as provided for in 2.1.8 is used in place of SG8.

(3) Seating on lintel for spans over 1.5 m to be 450 mm long by wall width. Seating 300 mm for spans less than 1.5 m.

(4) Rafters/truss to span parallel to gable walls

### C Table 9.2

Table 9.2 allows bigger spans than NZS 3604 Section 15

## 9.3 Concrete lintels

### 9.3.1

Concrete lintel sizes are given by:

- (a) Table 9.3 for lintels supporting side walls and gable walls with earth over the lintels;
- (b) Table 9.4 for lintels supporting side and gable walls with timber framing over the lintels.

For spans up to 1.5 m, lintels shall be seated a minimum of 300 mm on the earth wall on either side of the opening. Lintels with a clear span of more than 1.5 m shall be seated a minimum 450 mm on the earth walls. For splayed reveals greater than 100 mm there is to be a 300 mm bearing at the widest part of the opening (450 bearing for spans above 1.5 m).

### 9.3.2

Concrete lintels, if at the same height of a concrete bond beam shall be continuous with the concrete bond beam on either side of the opening.

Concrete lintels shall not interrupt a timber bond beam.

### 9.3.3

A concrete lintel shall be the same width as the wall supporting it minus the width of any external insulation shown as 56 mm in Figure 8.5 for concrete bond beams.

**C 9.3.3**

While this insulation is not essential to achieve compliance with NZBC clause H1, the insulation of this thermal bridge is a prudent insulation improvement. The bond beam and lintel tables in this standard have been calculated to accommodate an overall width reduction of 56 mm, made up of 50 mm polystyrene insulation and 6 mm fibre-cement sheet to weather it.

**9.3.4**

Where required, the deepening of the concrete bond beam for the concrete lintel shall be as shown in Figure 9.5.

**9.3.5**

Concrete cover to steel reinforcement (i.e., ties) shall be 50 mm and concrete strength shall be in accordance with 2.6.5.2.

**9.3.6**

Sizes, reinforcement, and maximum spans of concrete lintels supporting timber-framed walls, and roof above, shall be in accordance with Tables 9.3 and 9.4 according to the snow load and Figures 9.3 to 9.8. Loaded dimensions are shown in Figure 9.1. The strength of the lintels incorporates provision of insulation on the exterior face of the concrete.

**9.3.7**

Concrete lintels supporting gable end earth walls higher than 1.2 m, or interior earth walls that are more than 300 mm higher than adjacent wall heights, shall be specifically designed. Such lintels are outside the scope of this standard.

**Table 9.3 – Side wall and earth gable concrete lintels with ground snow loads up to 2.0 kPa. 1.2 m maximum earth wall over lintel**

| Lintel clear opening<br>(m) | Concrete Lintel type      |                  |                  |
|-----------------------------|---------------------------|------------------|------------------|
|                             | Ground snow load<br>(kPa) |                  |                  |
|                             | $\leq 1.0$                | $< 1.0 \leq 1.5$ | $< 1.5 \leq 2.0$ |
| 0.6                         | B                         | B                | B                |
| 0.9                         | B                         | B                | B                |
| 1.2                         | B                         | B                | B                |
| 1.5                         | B                         | C                | C                |
| 1.8                         | C                         | C                | C                |
| 2.1                         | C                         | C                | C                |
| 2.4                         | C                         | C                | C                |
| 2.7                         | C                         | D                | D                |
| 3.0                         | D                         | D                | E                |

NOTE –  
1. Rafter/truss span max 8.0 m, spacing up to 1.2 m  
Minimum bearing 450 mm long by wall width wide

**Table 9.4 – Side wall and earth gable concrete lintels with ground snow loads up to 2.0 kPa. Timber gable end and window head framing**

| Lintel clear opening<br>(m) | Concrete lintel type      |                  |                  |
|-----------------------------|---------------------------|------------------|------------------|
|                             | Ground snow load<br>(kPa) |                  |                  |
|                             | $\leq 1.0$                | $< 1.0 \leq 1.5$ | $< 1.5 \leq 2.0$ |
| 0.6                         | A                         | A                | A                |
| 0.9                         | A                         | A                | B                |
| 1.2                         | B                         | B                | B                |
| 1.5                         | B                         | B                | B                |
| 1.8                         | B                         | B                | B                |
| 2.1                         | B                         | B                | C                |
| 2.4                         | B                         | C                | C                |
| 2.7                         | C                         | C                | C                |
| 3.0                         | C                         | C                | C                |

**NOTE –**

- (1) Rafter/truss span max 8.0 m, spacing up to 1.2 m
- (2) Minimum bearing 450 mm long by wall width wide
- (3) Seating on lintel for spans over 1.5 m to be 450 mm long by wall width.  
Seating 300 mm for spans less than 1.5 m
- (4) Rafters/trusses to span parallel to gable walls

### 9.3.8

Where a concrete lintel is combined with a concrete bond beam and with a structural diaphragm, the bond beam reinforcement may be included in the area of the lintel reinforcement provided that the area of the lintel reinforcement exceeds the minimum area of the bond beam reinforcement. See [Figure 9.5](#).

### 9.3.9

Where a concrete lintel is combined with a concrete bond beam without a structural diaphragm, the reinforcement of the lintel shall be either:

The maximum amount required by either the lintel or bond beam where the total length of the lintel lies within the middle two-thirds of the bond beam span; or

The summation of the reinforcement required by the bond beam and lintel where the lintel or any part of it is located outside the middle two-thirds of the bond beam span. Refer to [Figure 9.5](#).



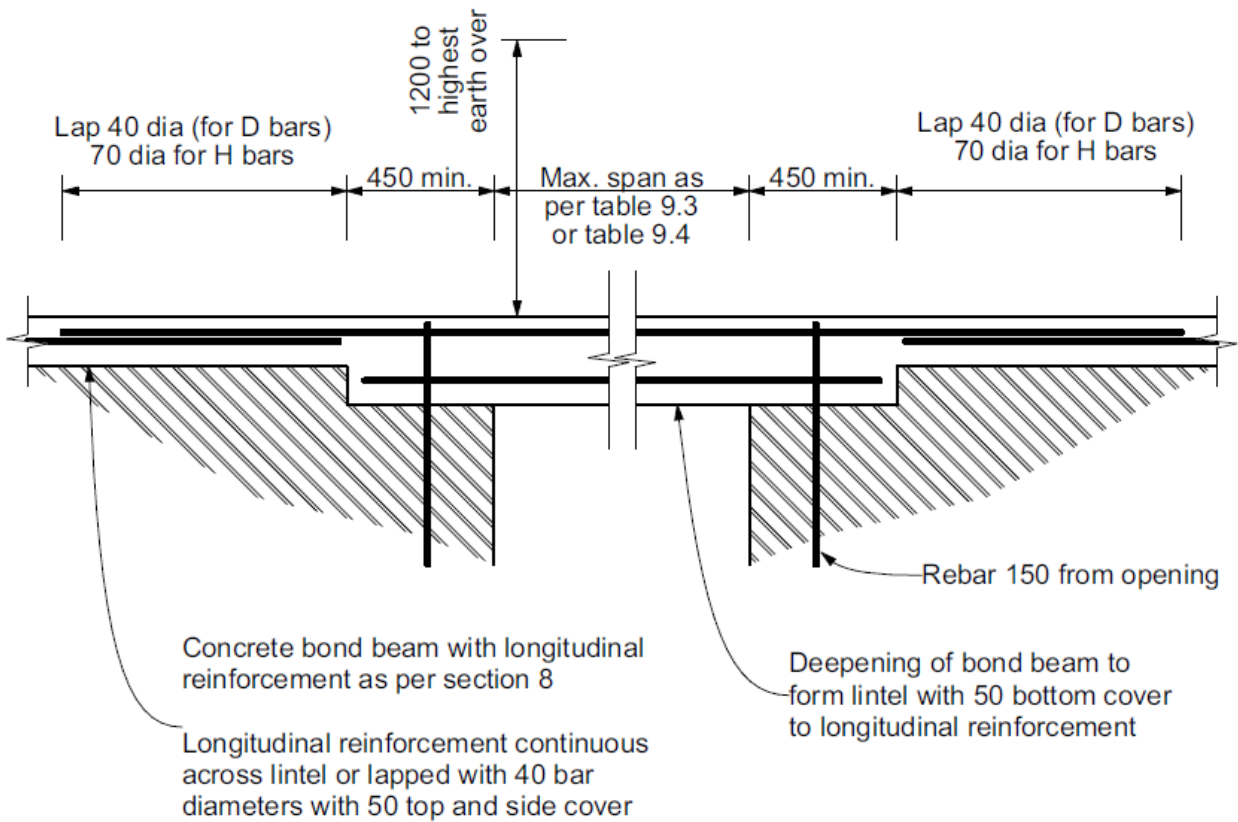

**Figure 9.5 – Concrete lintel general arrangement where lintel forms bond beam**

**NOTES --**

1. Where there are different sizes of bars lapping the diameter used for calculating the lap length shall be the diameter of the smaller bar.
2. Where there are different strength bars in the bond beam and lintel (D and HD bars) the lap length shall be as for the D bars.

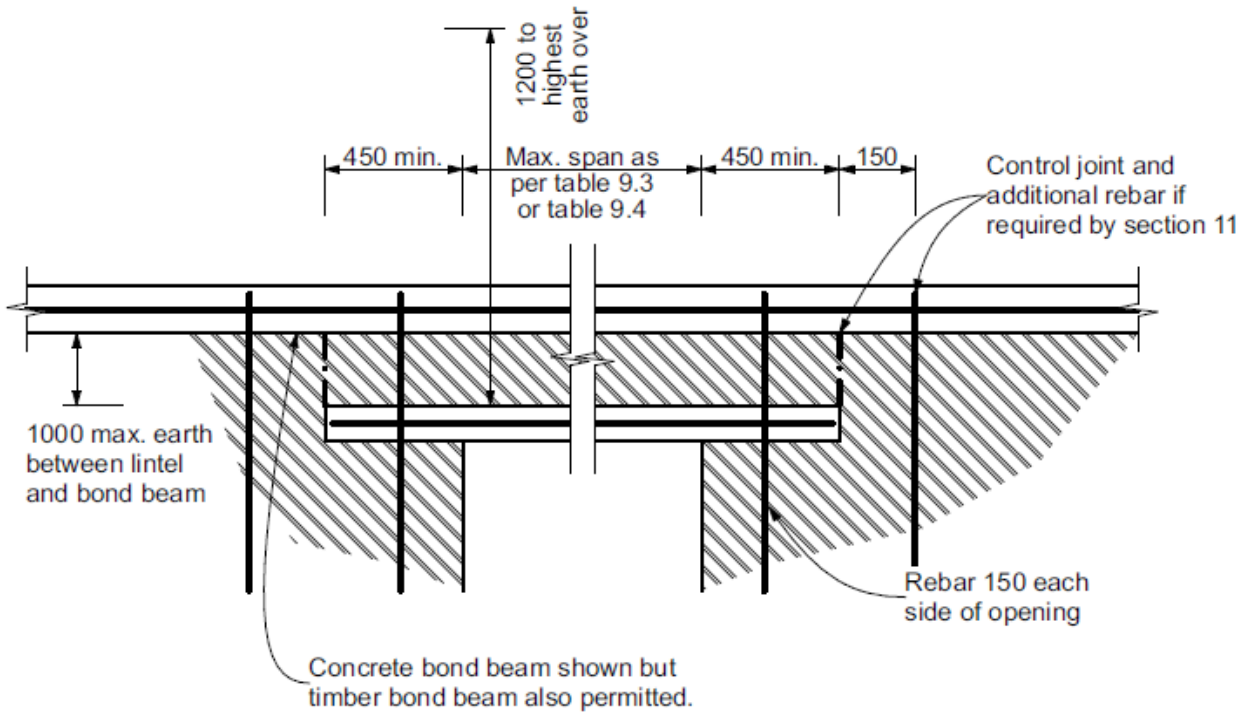

Figure 9.6 – Concrete lintel supporting concrete bond beam and wall above

Table 9.5 – Concrete lintel details

| Type | Depth (mm) | Longitudinal reinforcement |
|------|------------|----------------------------|
| A    | 150        | 2 D12                      |
| B    | 200        | 2 D12, 2 D16               |
| C    | 250        | 2 D12, 2 HD16              |
| D    | 300        | 2 D12, 2 HD16              |
| E    | 300        | 2 D12, 2 HD20              |

NOTE –

- All ties or stirrups R6@ 100 mm crs
- Lintel width equals the wall width minus 56 mm for insulation and protection. Insulation and its protection may be omitted

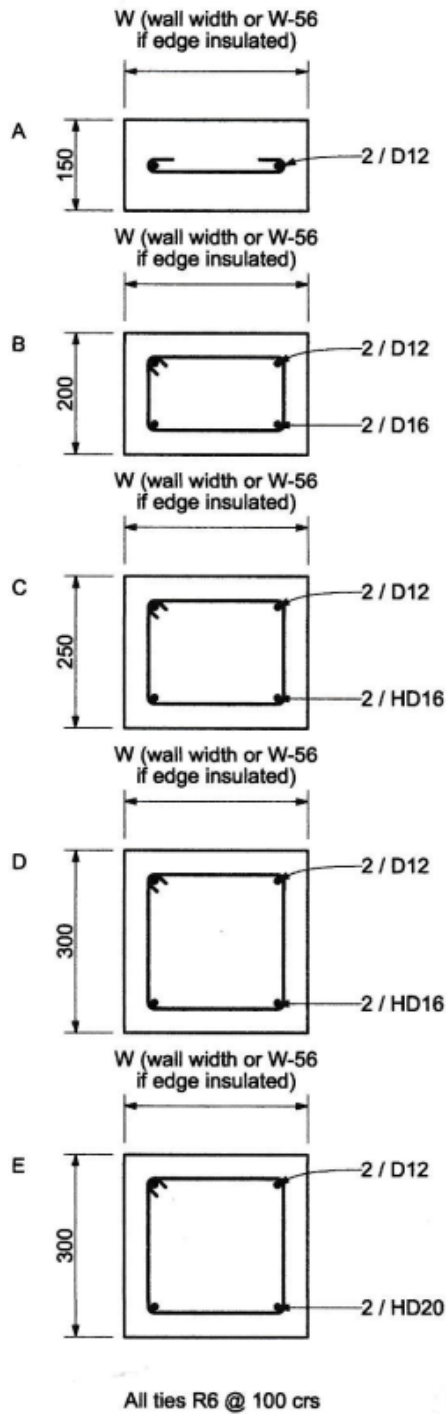
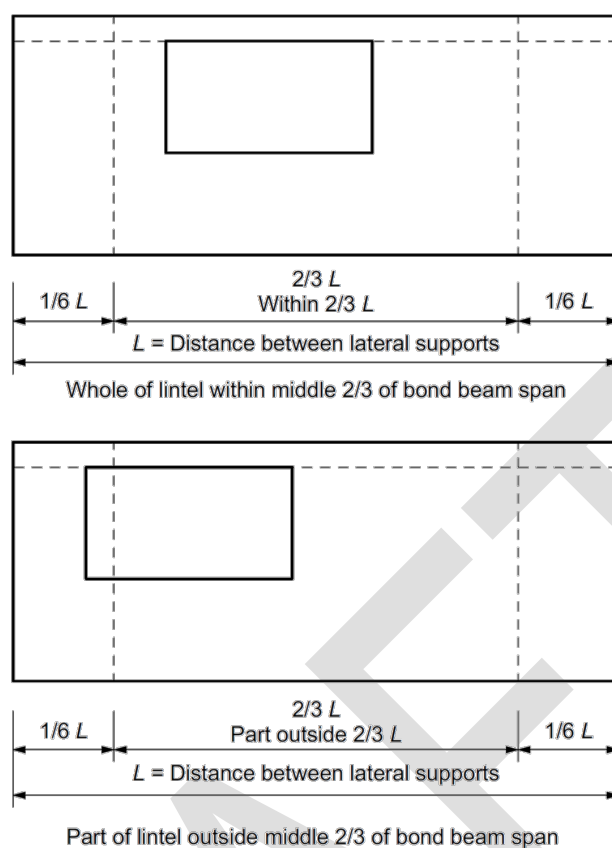

Figure 9.7 – Concrete lintel sizes and reinforcement



**Figure 9.8 – Concrete lintel within and outside middle two-thirds of bond beam span**

#### 9.3.10

The reinforcement of concrete lintels shall extend either side of the opening as shown in [Figure 9.5](#) and [Figure 9.6](#). Where the lintel contains four longitudinal bars, this clause applies to the upper two bars only.

#### 9.3.11

Laps for joining lintel and bond beam reinforcement shall be as shown in [Figure 9.5](#) and its notes.

#### 9.3.12

No laps in reinforcement shall be within 300 mm of the opening.

## 10 WALL OPENINGS AND FIXINGS

### 10.1 Windows

#### 10.1.1 Anchoring of joinery frames to walls

Windows and door frames shall be anchored securely to the earth wall. Details of anchor devices for anchoring door and window frames are shown in Figure 10.1.

Joinery may be fixed to earth walls by screw or nail fixing to wooden inserts as per Figure 10.1 or by masonry nails or non-expanding masonry screws to rammed earth or pressed brick walls.

#### **C10.1.1**

*The drawing note '20 diameter hole for D12 vertical reinforcing rod (if required)' relates to the accommodation of wall reinforcing and is not a requirement for additional reinforcing for the frame fixing.*

*Anchor devices may be installed after construction but the most secure and economic devices are generally installed as the wall is being constructed.*

*Alternatively, a rough frame may be built into the wall as it is being constructed and the finished frame fixed to this frame after the completion of wall and door construction. Care is to be taken to ensure that all necessary shrinkage can take place without 'hang-up' on the rough frame. The shrinkage gap should be as table 10.1.*

#### 10.1.2 Door and window detail

Details are shown in Figure 10.2 to [Figure 10.15](#).

Vertical settlement occurs in earth walls and is to be provided for to prevent hang up and jamming of doors and windows.

Windows frames shall be fixed at the sides to earth walls only after the wall has settled. The trims only shall be fixed to either the wall frame or the window frame but not to both until settlement is complete.

Windows and exterior doors with arched or sloping heads are outside the scope of this standard.

#### **C10.1.2**

*The detailing of doors and windows in earth walls requires special consideration when compared to conventional timber and masonry construction. The earth walls are thicker, the surface of the earth wall less uniform, and the wall material more fragile.*

*The major enemy of earth walls is water and careful attention to flashing and water control details is essential.*

*Requirements for window and door joinery are not included in this standard. For more information, designers may refer to:*

- (a) NZS 3504:1979      *Specification for aluminium windows;*
- (b) NZS 3610:1979      *Specification for profiles of mouldings and joinery;*
- (c) NZS 3619:1979      *Specification for timber windows.*

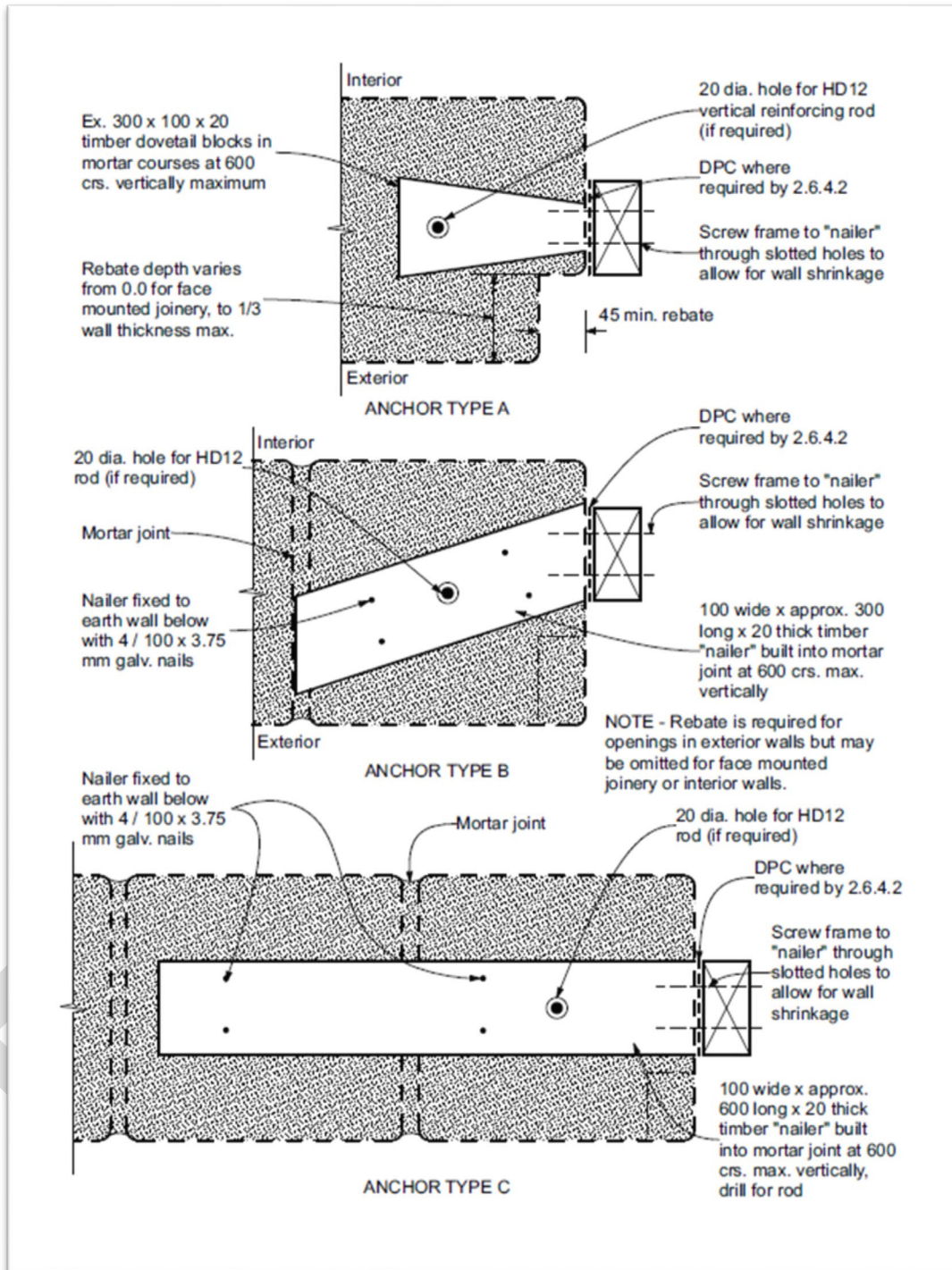

Figure 10.1 – Anchors for door, window, and timber partition frames for earth walls

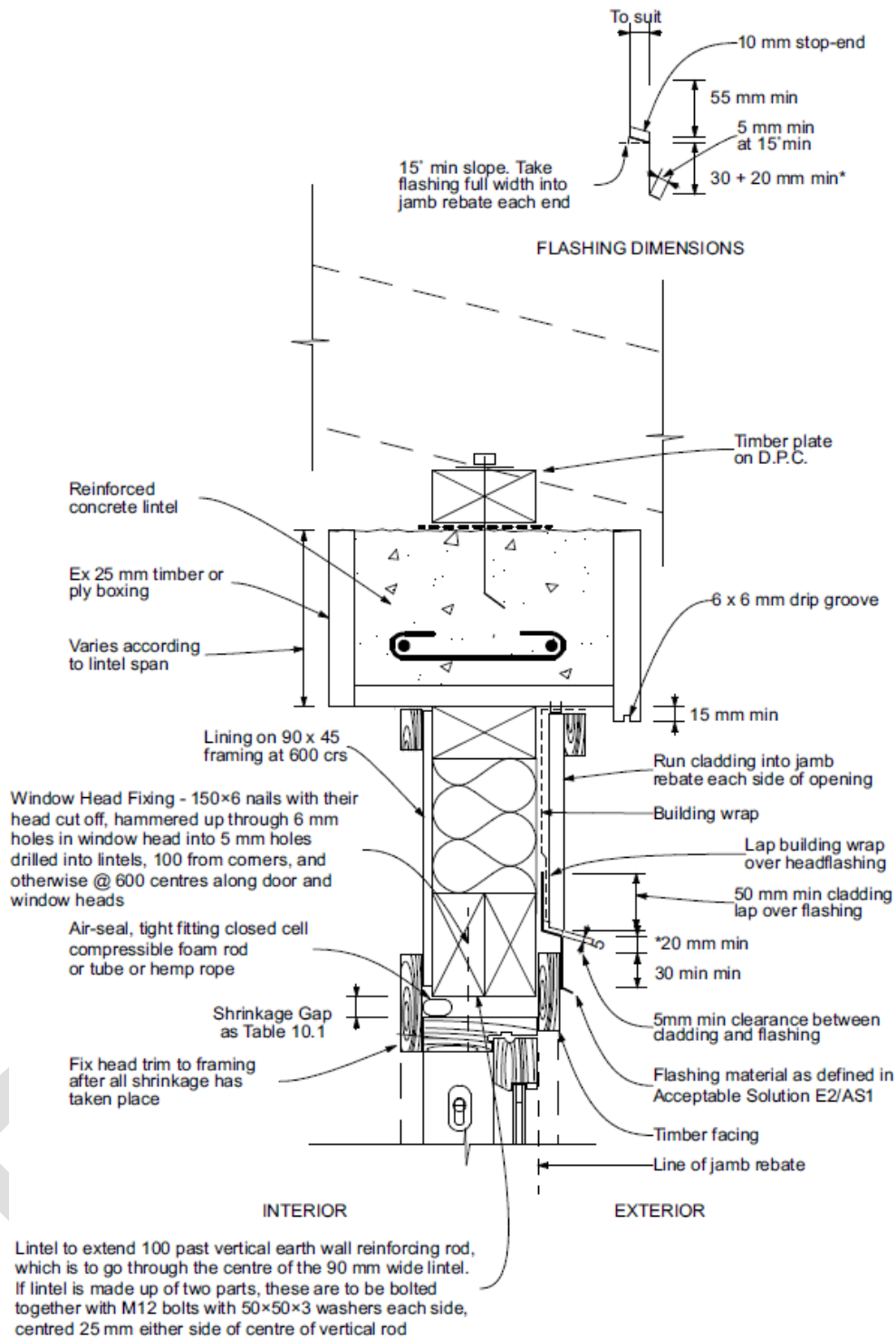

Figure 10.1 – Window head – Timber joinery with timber-framed wall insert

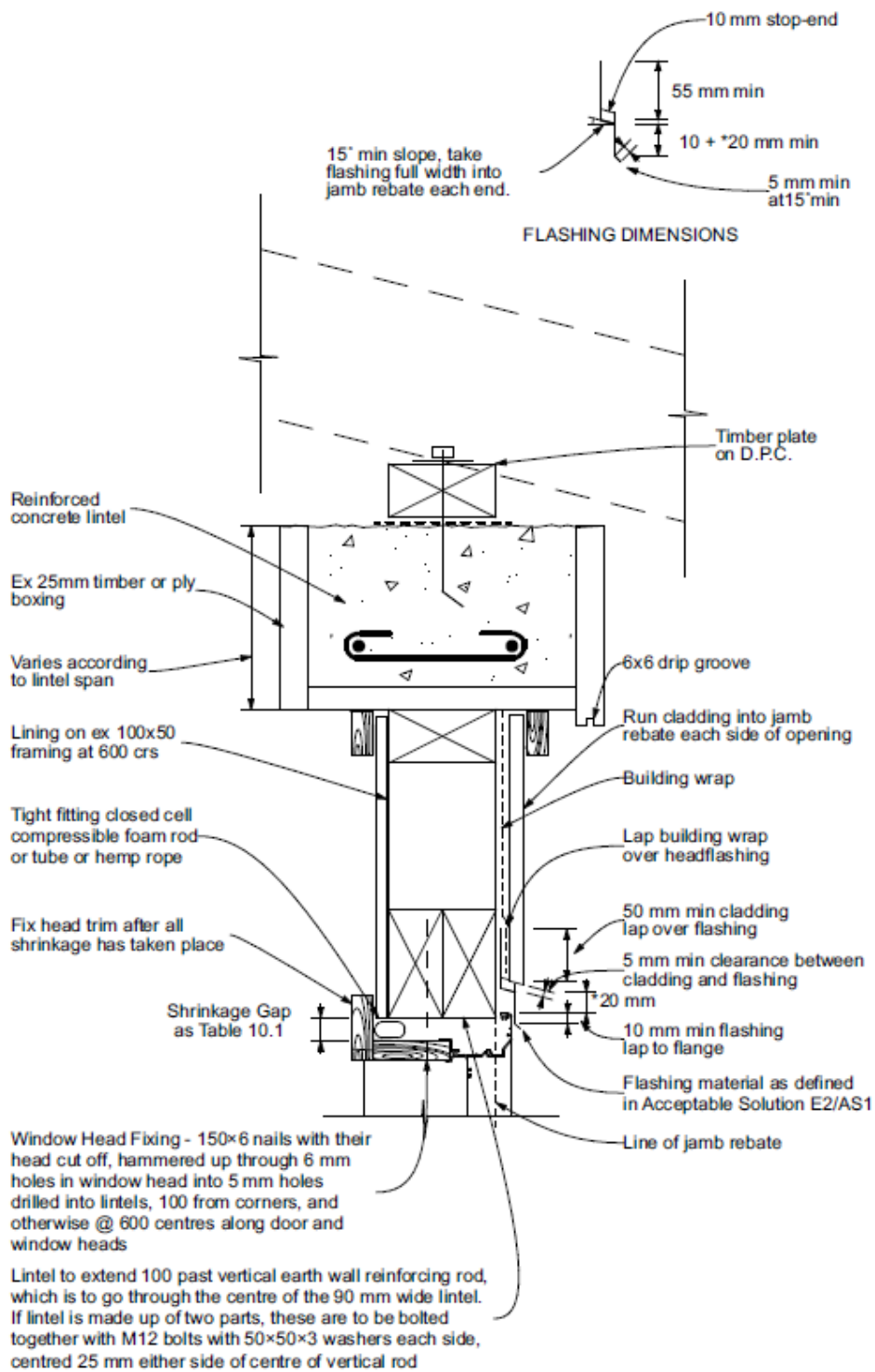

Figure 10.2 – Window head – Aluminium joinery with timber-framed wall insert



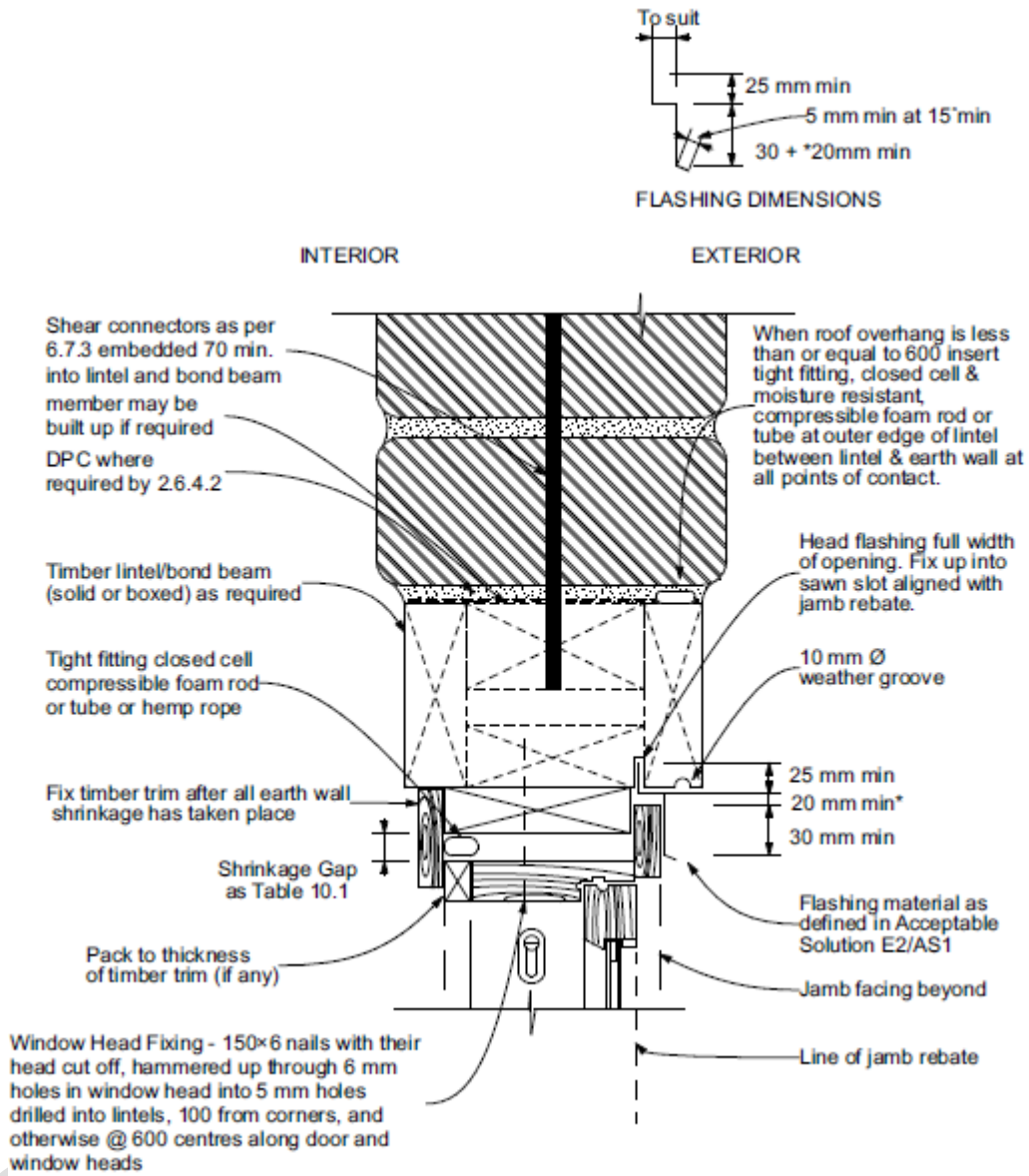

Figure 10.3 – Window head – Timber joinery with timber lintel

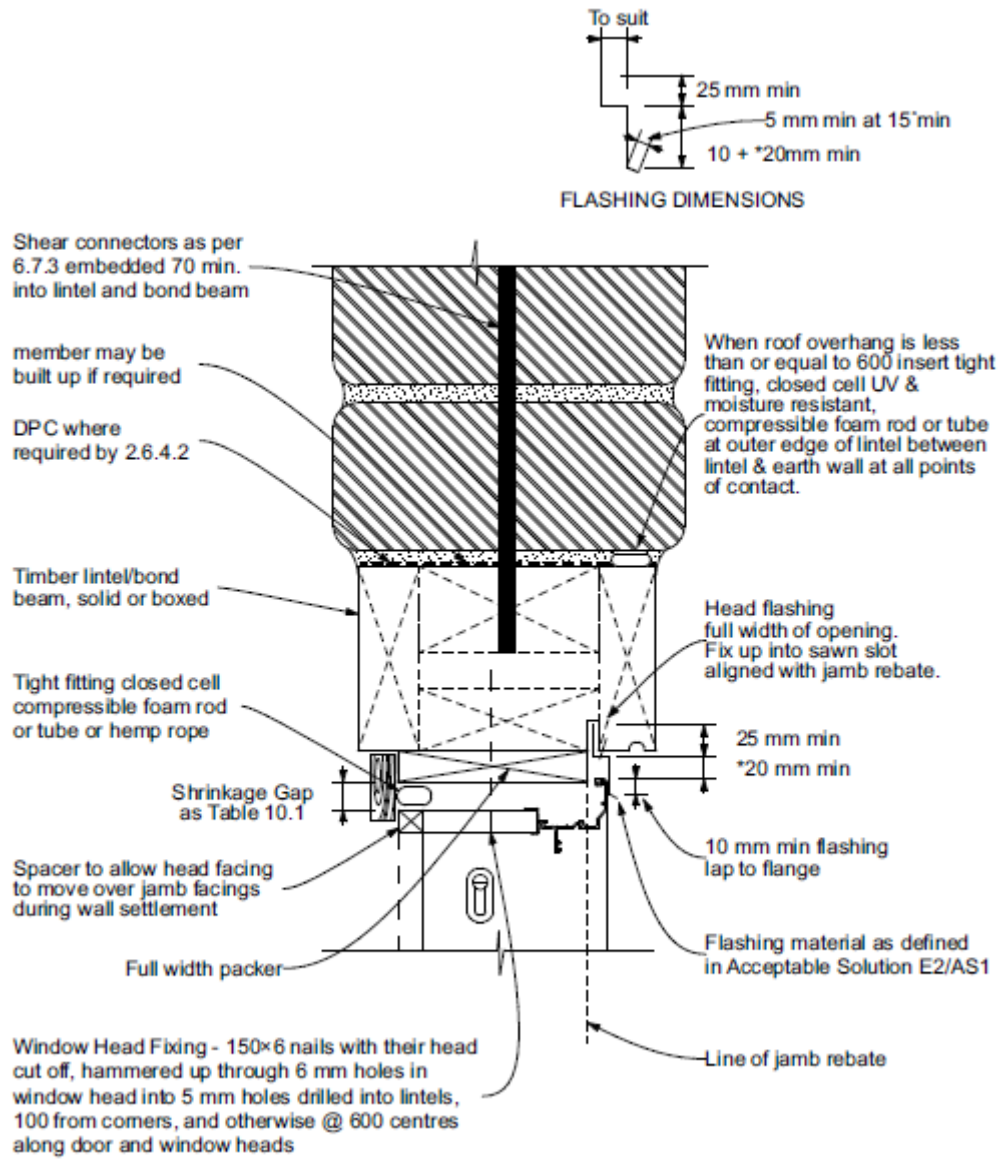

Figure 10.4 – Window head – Aluminium joinery with timber lintel

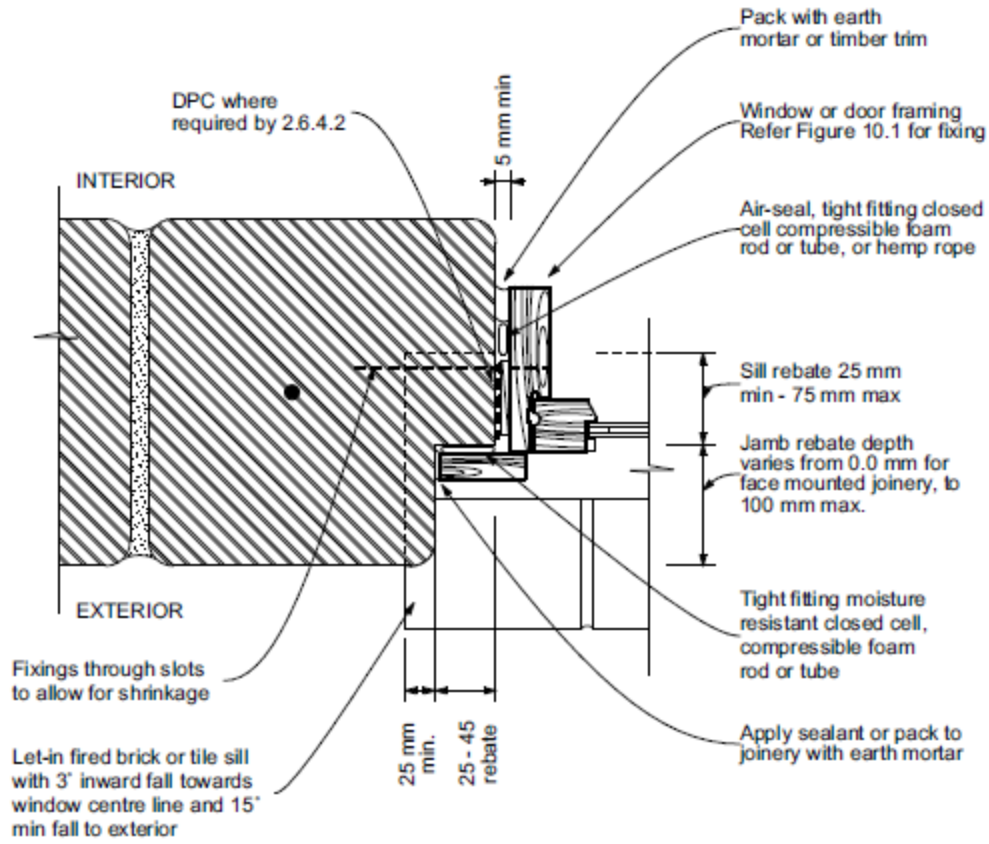

Figure 10.5 – Window jamb – Timber joinery

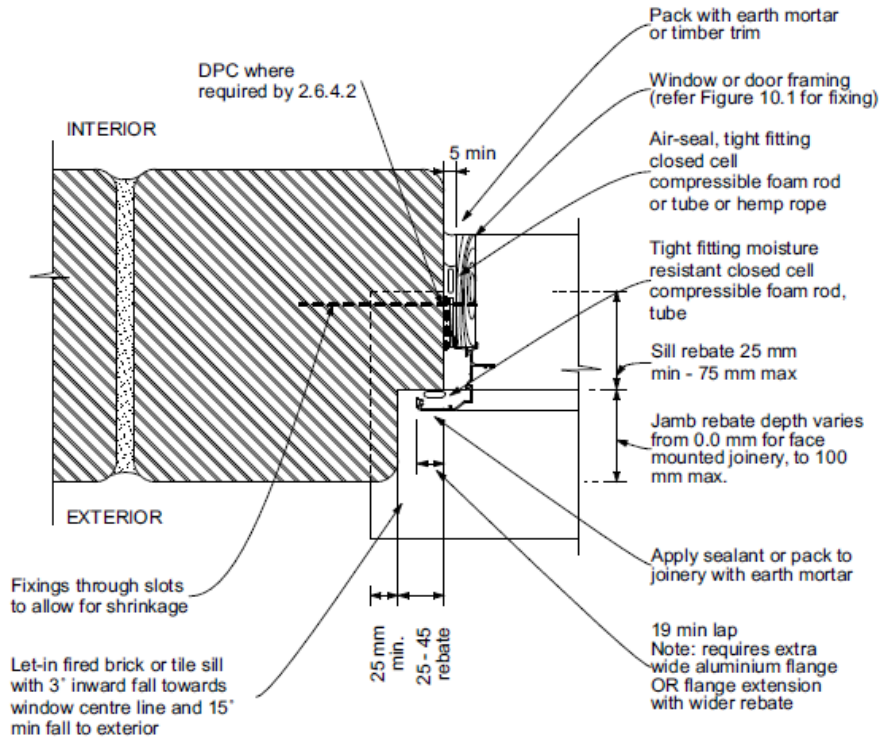

Figure 10.6 – Window jamb – Aluminium joinery

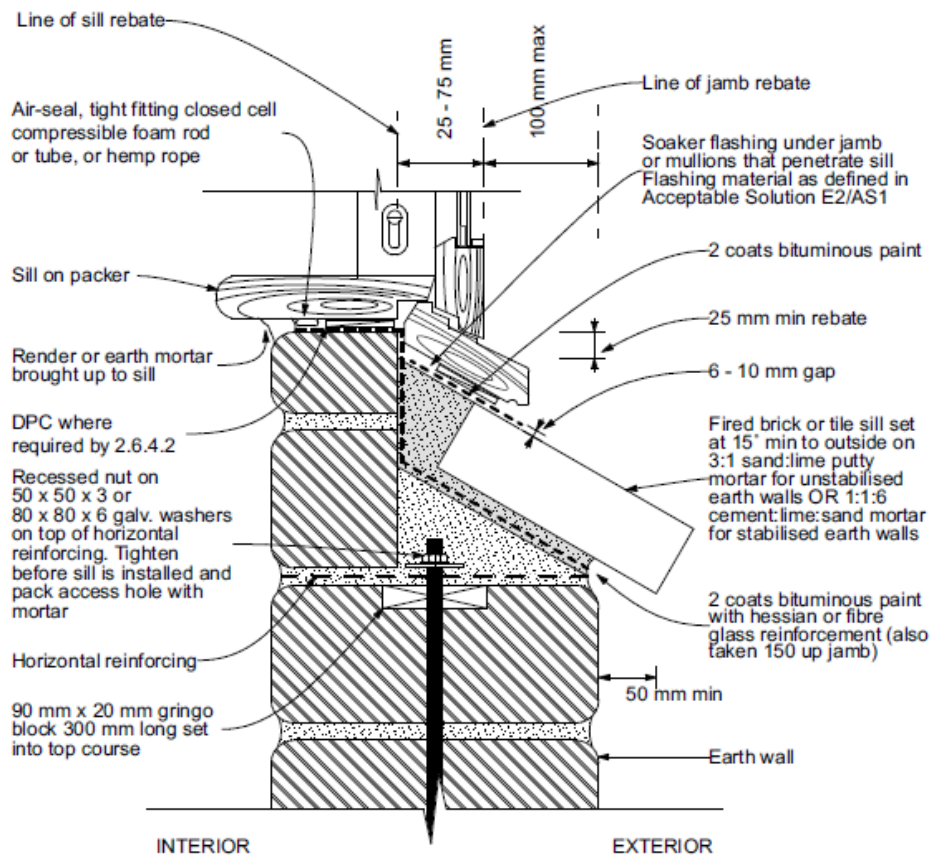

Figure 10.7 – Timber joinery with brick or tile sill

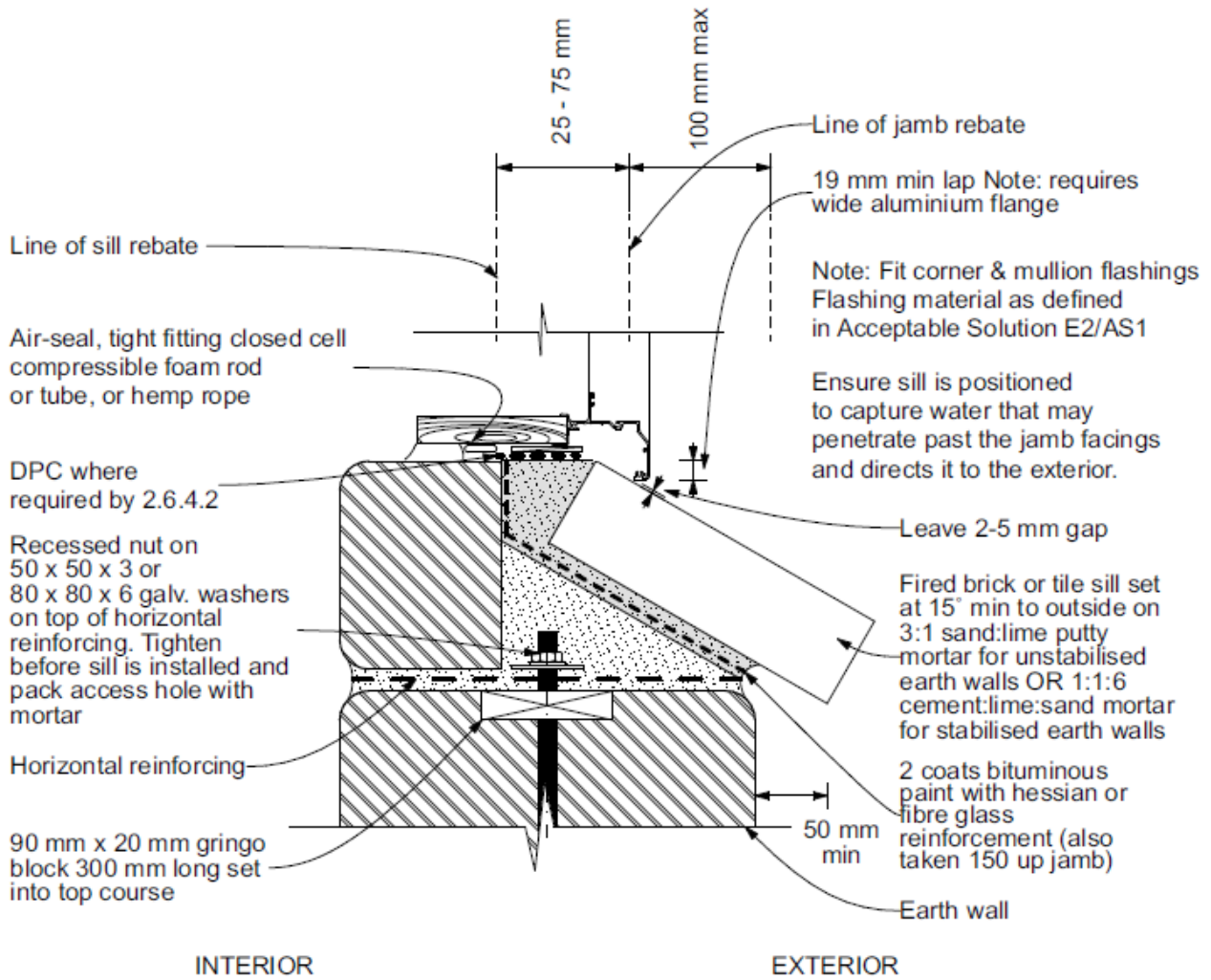

Figure 10.8 – Window sill – Aluminium joinery with brick or tile sill

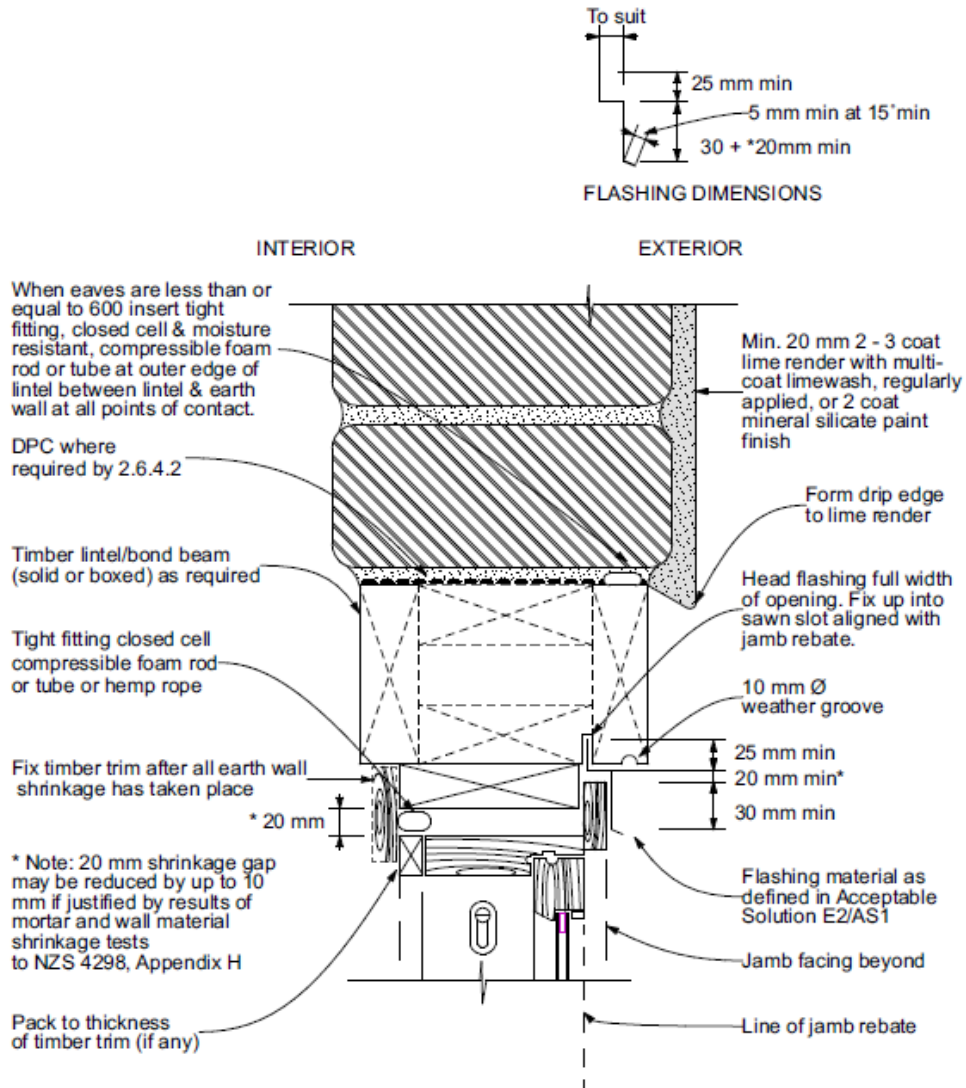

Figure 10.10 - Timber joinery head for lime plaster over solid earth wall

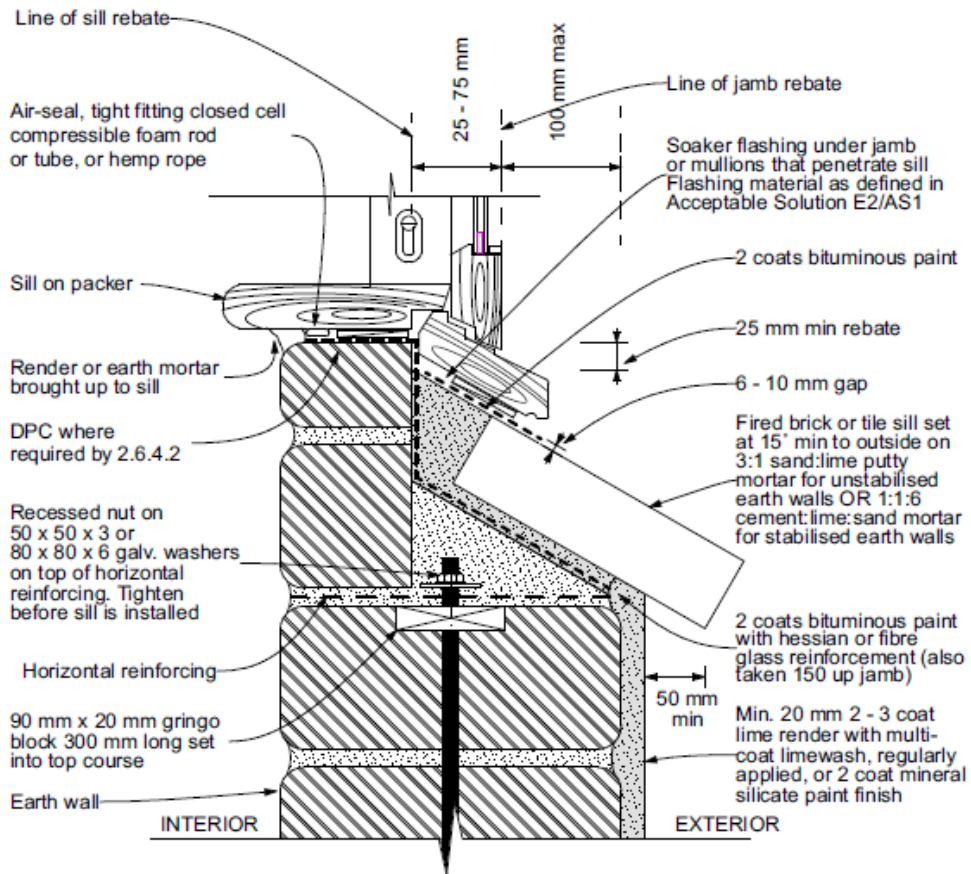

Figure 10.11 - Timber joinery sill for lime plaster over solid earth wall



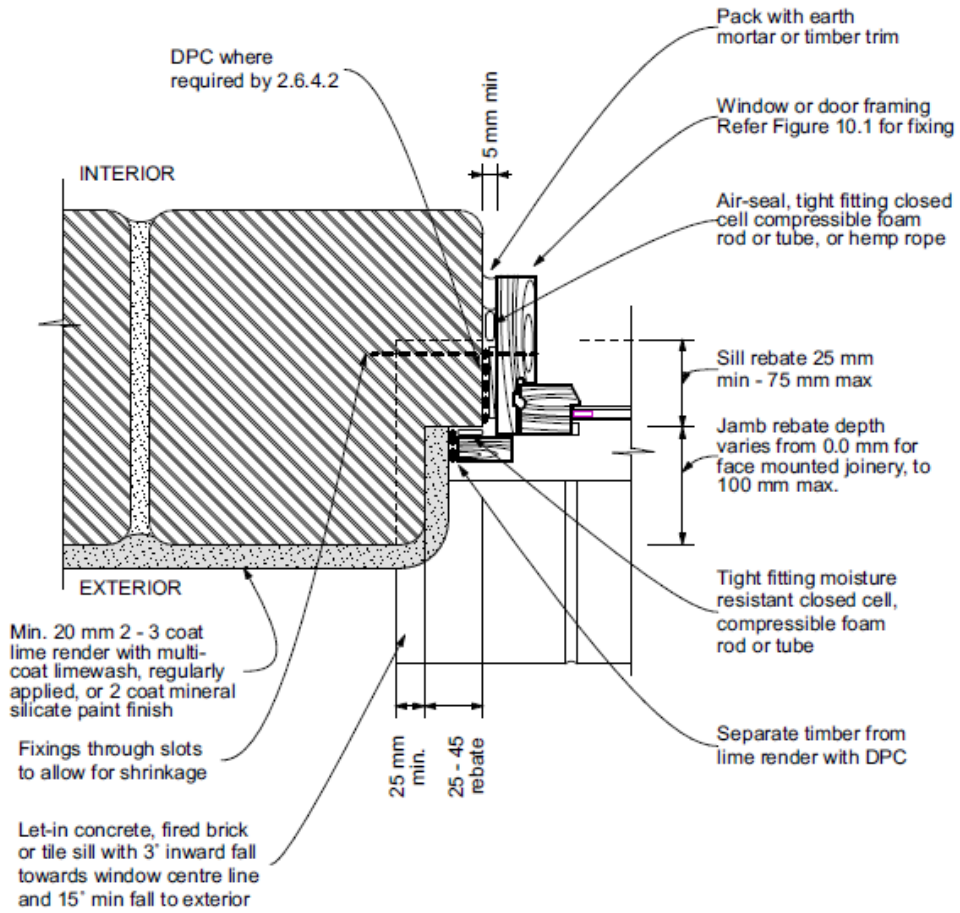

Figure 10.12 - Timber joinery jamb for lime plaster over solid earth wall

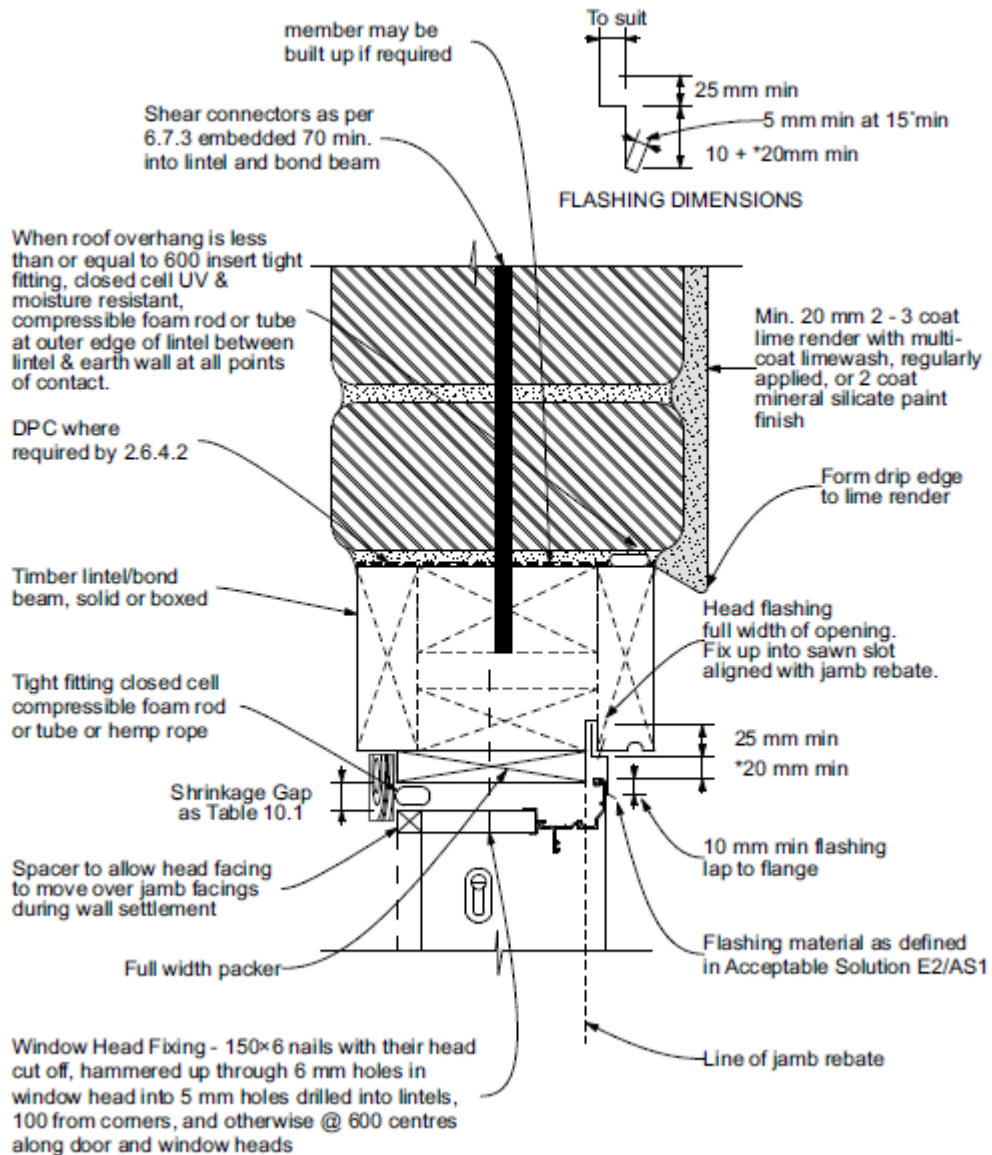

Figure 10.13 - Aluminium joinery head for lime plaster over solid earth wall

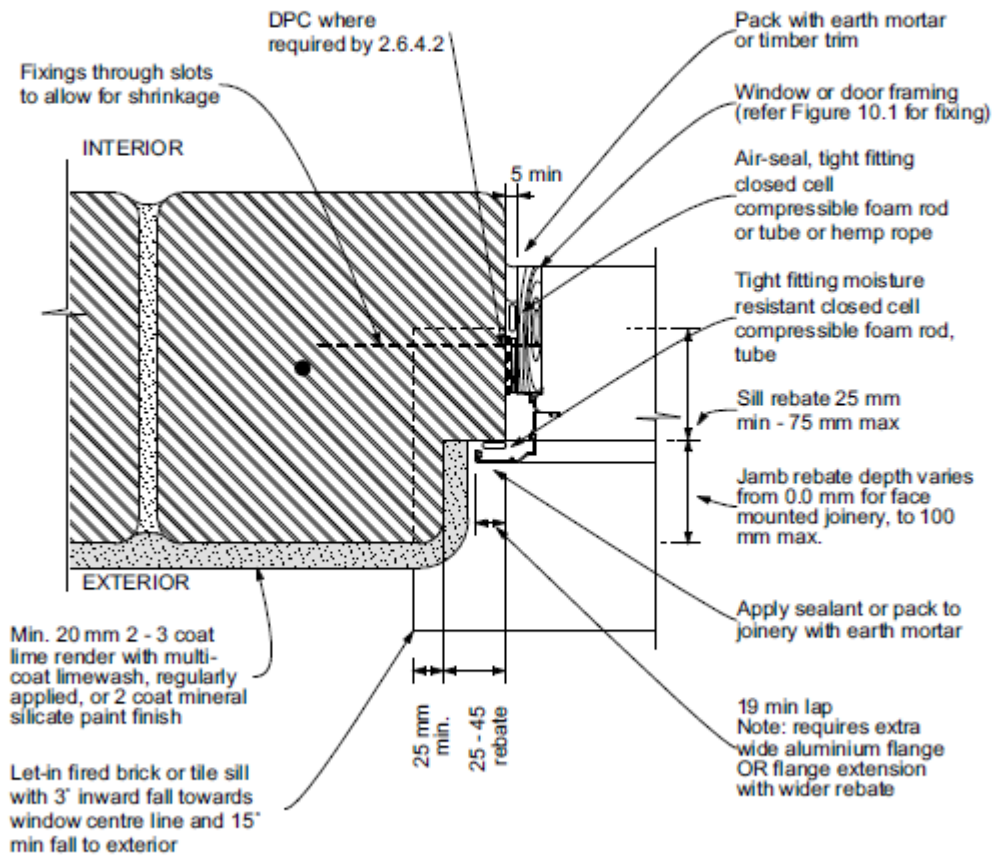

Figure 10.14 - Aluminium joinery jamb for lime plaster over solid earth wall

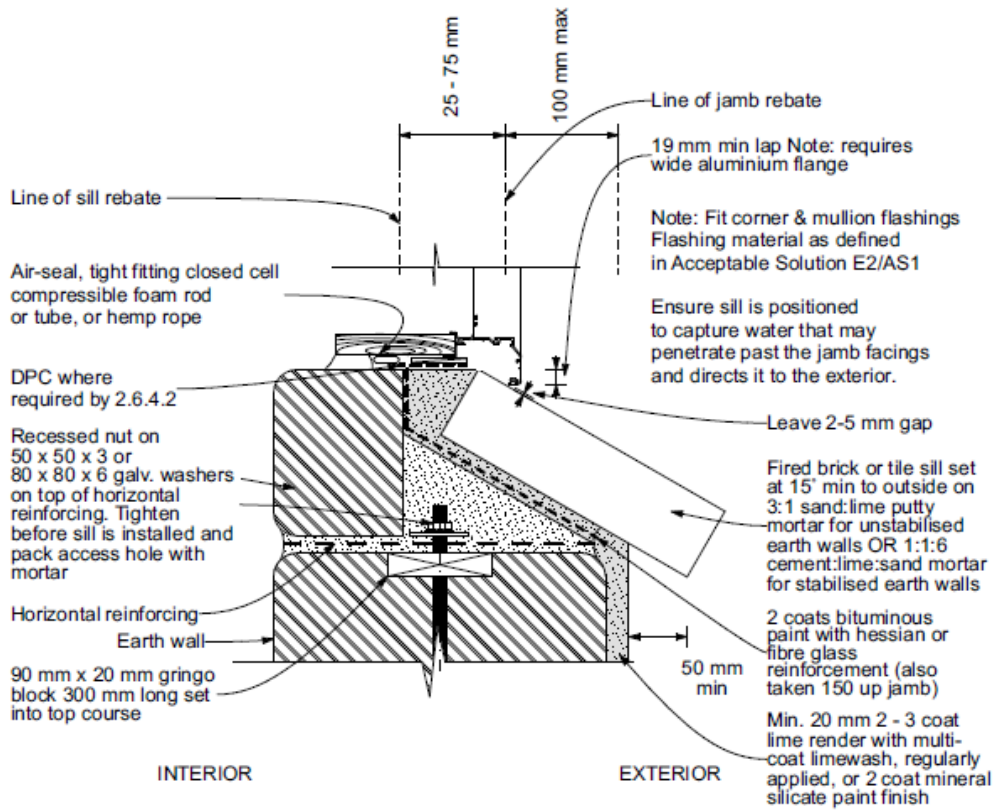

Figure 10.15 - Aluminium joinery sill for lime plaster over solid earth wall

## 10.2 Fixings for timber-framed walls

### 10.2.1 Shrinkage allowance

Fixings shall allow for settlement of the earth wall. Slotted holes are required for the fixings of timber framing to earth walls where the timber framing will not otherwise allow settlement.

The slotted holes should provide for the shrinkage allowances to take place shown in Table 10.1.

Wait until all shrinkage is complete before fully tightening any fasteners.

**Table 10.1 – Shrinkage allowance for a 2 m height opening. Different heights may be extrapolated and interpolated from this**

| Material                  | Shrinkage allowance and height of slotted hole |
|---------------------------|--|
| Adobe brick heavy density | 20 mm  |
| Adobe brick low-density   | 30 mm  |
| Rammed earth              | 5 mm   |
| Pressed brick             | 10 mm  |
| Cob heavy density         | 40 mm  |
| Cob low-density           | 50 mm  |

### 10.2.2 Connections between framing and earth wall

The studs of a timber-framed wall shall be fixed to an earth wall with anchors in accordance with Figure 10.1 or with three 12 mm diameter coach bolts through the end stud of the timber-framed wall with a durable timber block set into the outside of the earth wall at top, mid-height, and bottom.

### 10.2.3 Connections between roof structure and walls

The studs of a timber-framed wall shall be fixed to the roof structure as shown in Figure 10.12. Lateral forces from wall framing are to be transferred to the roof, ceiling framing or diaphragm by vertical D12 dowels or M12 coach screws. These fixings shall be at a maximum spacing of 600 mm. They shall be secured in position in the roof structure and run in a hole 2 mm oversize in the top plate of the timber-framed wall. Scotias shall be fixed to the structure and not fixed to the timber-framed wall so as to allow vertical relative movement.

The detail of Figure 10.16 shall be used only for a non-loadbearing wall.

#### **C10.2**

*The majority of shrinkage within earth walls takes place within the first month. It may take up to a year before all shrinkage has taken place so consider access to any fasteners to allow final tightening.*

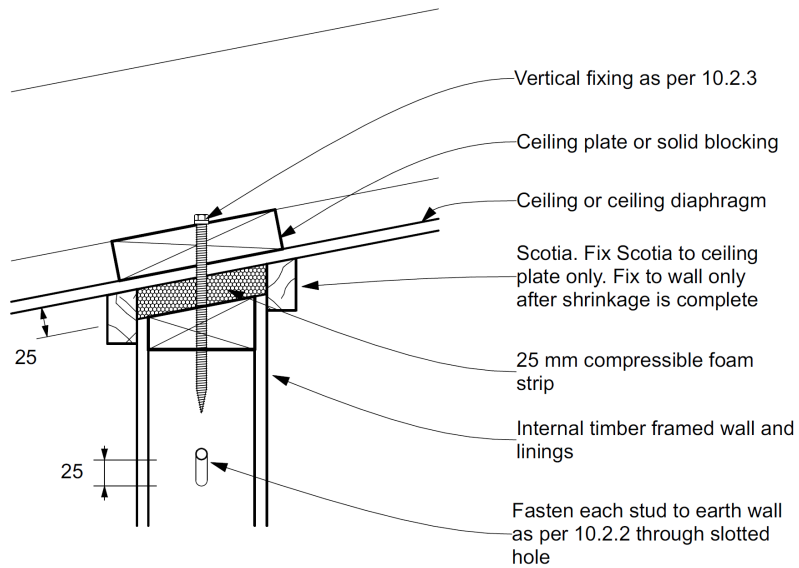
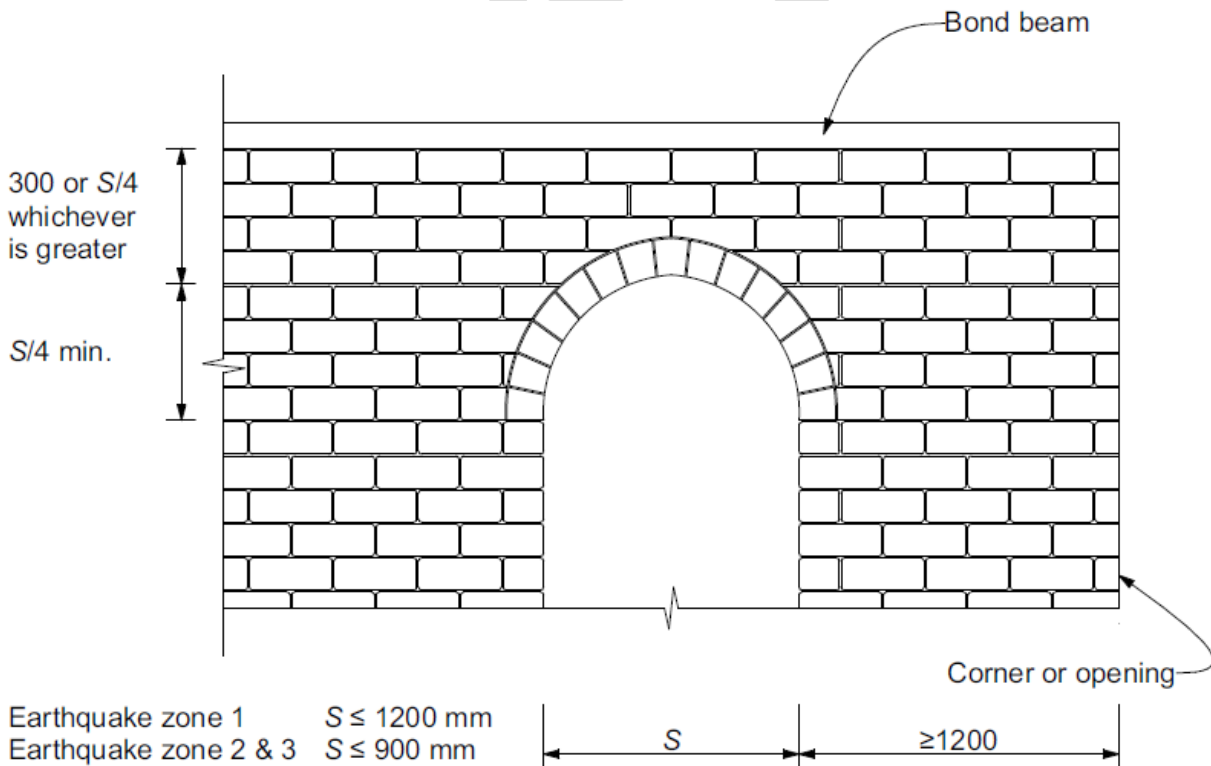

**Figure 10.16 Non-loadbearing internal wall fixing to allow for shrinkage**

**10.3.9 Arches**

**10.3.1**

Earth bricks may be used to form arches over openings as shown in [Figure 10.17](#).



**Figure 10.17 - Arch at door, window or opening**

**10.3.2 10**

The maximum span ( $S$ ) of openings with arches shall be 1200 mm in earthquake zone 1 and 900 mm in earthquake zones 2 and 3.

### 10.3.3

The height of the earth wall above the underside of the arch and below the bond beam at the top of the wall shall be a minimum of one-quarter of the span of the opening or 300 mm, whichever is the greater.

### 10.3.4

The side of the arched opening shall be a minimum of 1200 mm from any other opening or external corner.

#### **C10.3**

*The bricks making up the arch may be specially shaped or may be parallel sided. However, parallel sided bricks may present difficulties in achieving mortar joint thickness within the allowable range. To prevent arches moving downwards from mortar shrinkage the innermost brick edges in an arch made of parallel sided bricks may be laid touching edge to edge with minimal or no mortar between. This is acceptable trade practice.*

*Arches for an exterior environment will need to have SED to satisfy NZBC clause E2 requirements.*

*Arches in rammed earth or poured earth are subject to SED to eliminate their tendency to crack.*

*Adobe bricks forming the arch may be in contact along the soffit of the arch.*

## 10.4 Penetrations

### 10.4.1

The upper surface of elements (for example pipes and meter boxes) that penetrate external walls shall be sloped downwards to the exterior to direct moisture away from the wall and to discharge it clear of the wall surface.

#### **C10.4.1**

*Penetrations should be located where they are sheltered from wind-driven rain. This can be achieved by positioning the penetration in a sheltered location or as high as practical under eaves on the wall.*

### 10.4.2

Penetrations less than 200 mm wide shall meet the requirements of NZS 4298 clause 2.3.9.3 and shall be sealed all round with a tight-fitting moisture resistant compressible closed cell foam rod or tube that is finished 25 mm behind the wall surface, with the resulting gap filled with:

- (a) For unstabilised earth construction, a compatible unstabilised mortar;
- (b) For stabilised earth construction, a compatible stabilised mortar.

#### **C10.4.2**

*Generally sealants do not adhere well to earthen surfaces with the possible exception of dense stabilised rammed earth or pressed earth brick.*

### 10.4.3

Penetrations more than 200 mm wide (for example meter boxes) shall be anchored as required in section 9, 10.1.1, and Figure 10.1 and shall meet the following requirements:

- (a) Where the depth of the penetration is more than one-third of the wall depth, the penetration shall incorporate head, jamb, and sill details similar to those required for windows;
- (b) Where the depth of the penetration is less than one-third of the wall depth, the penetration shall be sealed all round with a compatible mortar.

### 10.4.4

No penetrations or recesses are permitted in a bracing panel other than a maximum 50 mm diameter pipe, which shall be more than 600 mm from the edge of a bracing panel.

## 11 CONTROL JOINTS

### 11.1 General

#### 11.1.1

Every earth wall except for adobe bricks, cob, and constructed with mortar that does not contain cement, shall have control joints at spacings that will ensure that any cracking which occurs will not cause the wall to fail strength or serviceability requirements. Control joints are optional in adobe or cob construction that are not cement or lime stabilised.

##### **C11.1.1**

*Control joints are optional for unstabilised cob and unstabilised adobe walls.*

*Control joints in unstabilised adobe or cob are generally not required. What shrinkage and movement there may be in an adobe or cob wall is generally evenly distributed micro-cracking.*

#### 11.1.2

Longitudinal shrinkage in earth building materials shall be controlled by providing vertical control joints at not more than 3.6 m centres in adobe containing cement, pressed brick, rammed earth, and poured earth and where the ratio of wall height to wall length in any wall panel exceeds 1:2.

##### **C11.1.2**

*Low wall panels beneath wide windows can be prone to shrinkage cracking if the height-to-length ratio exceeds 1:2.*

#### 11.1.3

Vertical shrinkage control joints shall be located in rammed earth, adobe containing cement, pressed brick, and poured earth as follows:

- (a) At both sides of an opening;
- (b) Any step changes in wall height;
- (c) At changes in wall thickness;
- (d) Where earth brickwork is supported by a lintel, at each end of the lintel up to the bond beam or top plate; and
- (e) Adjacent to corners of walls or intersections within a distance equal to half the control joint spacing but not less than 900 mm from the outside edge of an external corner.

See Figure 11.1.

##### **C11.1.3**

*Control joints too close together or too close to a corner have the potential to interfere with the effectiveness of the continuity of earth wall material, or the running bond pattern of bricks around that corner.*



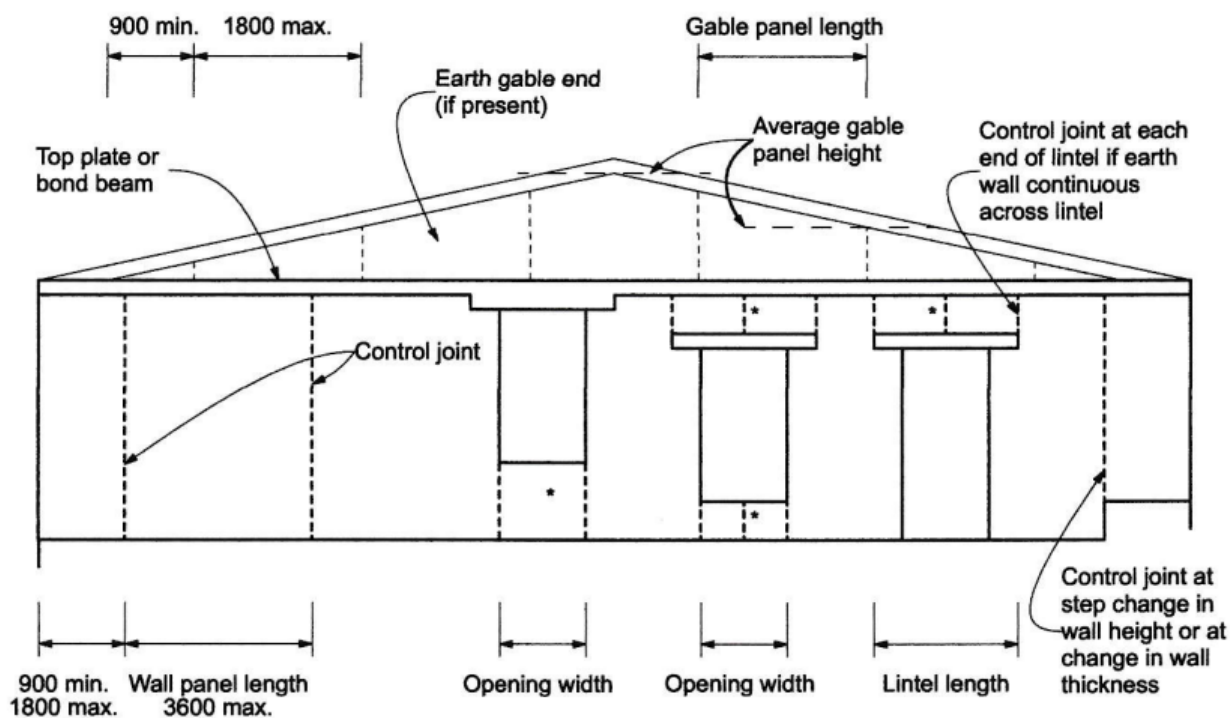

\* For wall panels over 450 mm high, over lintels, or under sills, and/or where the ratio of wall height to wall length between control joints exceeds 1:2, then provide additional intermediate control joints.

For gable end panels, the average height of panels shall be used (see fig 6.2), with a minimum gable panel length of 900 mm and max of 1800 mm.

Figure 11.1 Location of control joints

#### 11.1.4

Control joints shall not be located in such a way that they interfere with the requirements for bonding or stability.

#### 11.1.5

Control joints shall be weatherproof when located in exterior walls.

#### **C11.1.5**

*Light should not be visible through a control joint. Control joints should be insect-proof. Neither of these properties are required for compliance with the NZBC but are desirable attributes of quality buildings.*

#### 11.1.6

Control joints shall be constructed so as to transfer forces across the joint loads perpendicular to the wall face but allow expansion and contraction of each wall panel.

Bond beams that support diaphragms or otherwise provide lateral supports to walls shall be continuous through control joints. Lintels and their supports shall also be continuous through control joints.

#### 11.1.7

Horizontal reinforcement other than in bond beams and lintels shall not be continuous at control joints.

#### 11.1.8

Earth walls shall contain a reinforcing rod immediately either side of the control joint.

**11.2 Control joints for rammed earth walls**

Control joints for rammed earth walls, or in cob walls if used, shall be in accordance with Figure 11.2.

Mechanical keys shall be formed at each control joint and 25 mm x 25 mm bitumen-impregnated compressible foam strip shall be fixed as shown in Figure 11.2 for the full height of the wall. The foam strip shall extend 100 mm along the floor slab to ensure a complete seal of the bottom of the construction joint.

Horizontal construction joints for rammed earth, where there is a break in the construction sequence of more than 24 hours, shall be in accordance with Figure 11.3

**C11.2**  
 A 'V' joint as shown in Figure 11.2 and Figure 11.4 may be formed on both wall faces as shown.

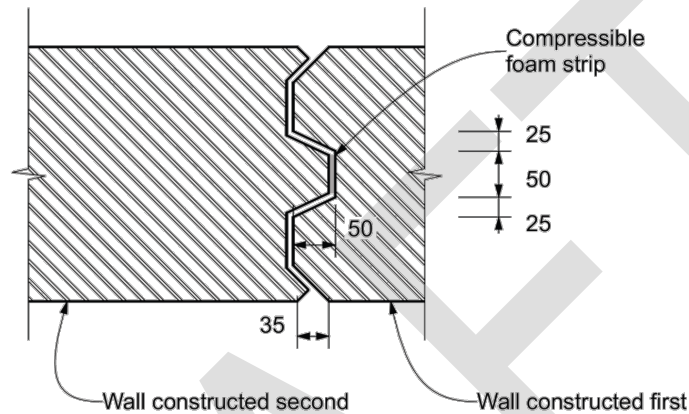

NOTE - Key former ex 100 x 50 (can be ex 150 x 50).

**Figure 11.2 Control joint for rammed earth or cob walls**

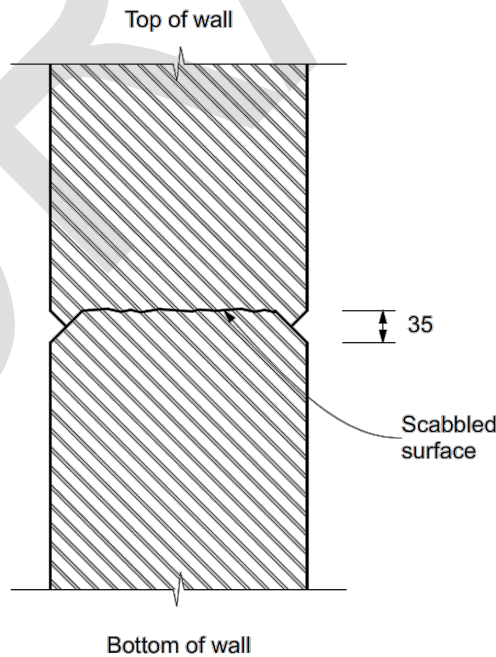

CROSS SECTION OF WALL

**Figure 11.3 – Horizontal construction joint for rammed earth walls**

### 11.3 Control joints for adobe and pressed brick walls

Control joints for adobe and pressed earth brick walls shall be a full-height continuous vertical mortar joint in accordance with Figure 11.4

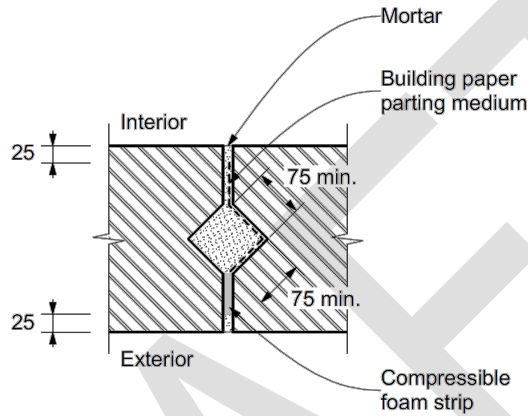

NOTE -  
The matching rebates on each side of the mortar joint may be "V" shaped as shown or semi-circular in plan.

Figure 11.4 – Control joint for adobe and pressed brick

## 12 EARTH FLOORS

### 12.1 General

This section deals with the design of earth floors in single-unit dwellings only, or buildings with foot traffic or loading conditions that are comparable.

#### C12.1

*Earth floors have a long history of successful use in New Zealand. Earth floors give a finish that is unlike that of other floors, and it is recommended that successful examples of the earth floors be viewed before the design of one into a building is undertaken.*

*It is recommended that a trial section of floor is laid for acceptance before construction starts.*

*If there is danger of flooding then it may be prudent to avoid an earth floor. Otherwise, the earth floor methods shown here can be used to design a durable floor but one that may not be free of shrinkage cracks or some surface unevenness that can be inherent in the nature of an earth floor.*

*Some earth floors have a hardness somewhat comparable to a timber floor, and can therefore be subject to damage from hard shoes, heavy foot traffic, or abrasion by furniture movement. However they have a history of performing well as long as the owners have been prepared to accommodate this by not subjecting the floor to frequent impact from furniture or appliances, especially from concentrated or heavy point loads, or hard footwear, especially stiletto heels. A well installed earthen floor can have the hardness and durability of a shingle road with the loose shingle bound tightly.*

*Earth floors may not be suitable for use in areas of very high traffic or where a more durable finish is desired. Earth floors may be suitable for use in areas such as garages or workshops but this is outside the scope of this standard.*

### 12.2 Scope

This section deals with floors that are made from:

- (a) Adobe;
- (b) Cob;
- (c) Pressed earth brick.

### 12.3 Performance criteria

Earth floors shall be level, and have adequate resistance to compression, impact, and moisture. [Materials listed in 12.2 that meet the testing requirements prescribed for wall construction \(NZS 4298 Table 2.1\) will be adequate for the construction of earth floors.](#)

### 12.4 Construction details

#### 12.4.1 Bearing of footings and earth floors

The depth of footings cleared ground level, granular fill, and [vapour barriers](#) shall be in accordance with 5.6.3. Footings shall be in accordance with 5.2, including Figure 5.10 and Figure 5.11.

#### 12.4.2 Minimum thicknesses

##### 12.4.2.1 Over compacted hardfill

The minimum thickness over compacted hardfill for:

- (a) Pressed brick is 75 mm;
- (b) Adobe is 120 mm;
- (c) Cob is 75 mm;
- (d) Cob over extruded polystyrene complying with clauses 13.4.8.2 and 13.4.8.3 is 150 mm.

**12.4.2.2 Over a reinforced concrete floor**

The minimum thickness of earth flooring over a reinforced concrete floor, which is to be a minimum of 100 mm thick for:

- (a) Adobe is 40 mm plus mortar thickness;
- (b) Pressed earth brick is 40 mm plus mortar thickness;
- (c) Cob is 40 mm.

**C12.4.2.2**

*Floors much thinner than these specified minimum thicknesses have been demonstrated to work in practice but are outside the scope of this standard.*

**12.4.3 Construction movement joints and crack control****12.4.3.1 Joints**

Movement joints in the floor **shall** be sited at one or both sides of a threshold between two rooms. Joints shall be immediately over and be continuous with control joints in the base. **An earth floor made from adobe or pressed earth bricks will automatically have movement control joints provided by the mortar joints, but designers may still consider the position of these joints.**

Floors **that** are not structurally independent of walls **are outside the scope of this standard.**

**C12.4.3.1**

*Any control joints in the substrate are likely to translate through subsequent layers, so control joints need to line up with control joints in slab below – making sure the below joint is true and located correctly is part of design and construction of the subfloor. By default, there are movement control joints at floor-wall intersections.*

*There is no maximum distance required between construction joints in earth floors, but matters of practicality in terms of areas that can be laid at one time may influence designers to stipulate them. Control joints should also be considered at any other points where there are large changes of horizontal dimension in the floor layout.*

*Cracking may be expected to occur in earth floors. As the floor is not a structural element this cracking is not of structural significance. Control joints and controlled cracking can help reduce random cracking but may not eliminate it. Cracks can be grouted but the grout cannot be assumed to be able to be a complete match with the remainder of the floor. A fibrous cob mix also helps eliminate cracking.*

*Cracking through the body of cob floors can be minimised by ensuring the use of a low shrinkage and/or fibrous mix, or by installing the floor in more than one layer, each progressively thinner. Geogrid or hessian reinforcing has been suggested as an option in an earth mortar layer between each layer but most practitioners have not found the need to do this. If the floor is laid up in layers, each layer is required to be well bonded to the previous layer by wetting and stiff brushing, with the final cob layer either a floated finish or an earth plaster layer 10 mm to 15 mm thick.*

*Any shrinkage cracks that do form once the floor is dry can be filled before the final finishing layer is applied. Hessian 'bandages' may be placed over the cracks. This allows the use of a wider range of material than would normally be used in a cob wall.*

*Earth floors may experience some cracking in a moderate seismic event. This risk can be reduced in earthquake zone 3, if earth floors are laid over a reinforced concrete slab.*

**12.4.3.2 Maximum length**

The maximum length of any earth brick in an earth brick floor shall be 450 mm.

**C12.4.3.2**

An earth floor made from adobe or pressed earth bricks will automatically have movement control joints provided by the mortar joints, but designers may still consider the position of these joints. There is no maximum distance required between construction joints in earth floors, but matters of practicality in terms of areas that can be laid at one time may influence designers to stipulate them.

Mortar joints within adobe or pressed earth brick floors are the weak points. Mortar cracking can be minimised with brick floors by ensuring a low shrinkage mortar that is laid as stiff as possible. Brick cracking is reduced by having smaller bricks.

**12.4.4 Concentrated or vibrating loads**

Earth floors shall not be used under any heavy appliances subject to vibration, for example clothes washing machines.

**C12.4.4**

Where point loads may occur under the feet of heavy appliances such as a fridge or a stove it may be desirable to insert a piece of harder material in the surface that will spread the load over a wider area, such as a ceramic tile mortared into the earth floor with an earth or lime mortar, or by inserting a section of concrete floor under that appliance or point load.

**12.4.5 Tolerances on level and surface finish**

Flatness or surface irregularity is allowable without detriment to the satisfactory performance of the floor and the permissible limits associated with these variations will depend on many factors.

The following tolerances shall be followed:

- (a) Finished floor level is to be within  $\pm 15$  mm of the finished floor level indicated on drawings;
- (b) The floor shall be without sharp changes in height, for example between different surfaces or between individual bricks or floor sections, of more than  $\pm 6$  mm over a 200 mm straight edge
- (c) The variation over a 1500 mm long straight edge shall be no more than  $\pm 15$  mm;

**C12.4.5**

These tolerances can result in an undulating floor. Although some people find this an acceptable characteristic of earth floors, designers may specify tighter tolerances. *Where accuracy of surface may be important, such as under kitchen cabinetry, it is recommended that a concrete floor be used or an earthen floor mix that is easily trowel finished.*

*Greater accuracy to datum may need to be specified in small rooms, along the line of partition walls, in the vicinity of door openings, or where specialised equipment is to be installed directly on the floor. Over larger floors wider tolerances may be acceptable.*

- (d) The sand blinded hardfill under extruded polystyrene insulation in accordance with 12.4.8.2 and 12.4.8.3 shall be level to within 5 mm over a 2 m length.

**C12.4.5(d)**

*This to prevent 'lensing' beneath the polystyrene insulation that can induce cracking of the overlying earth floor under point loads.*

- (e) If smoke or fire doors are required more stringent tolerances shall be applied and shall be appropriate to the tested door system installed.

**12.4.6 Moisture control as required under NZBC clause E2**

A damp-proof membrane shall be installed over sand blinded compacted hardfill under all earth floors to the requirements of NZS 3604 and as shown in Figure 5.10 and Figure 5.11 to control rising damp.

**C12.4.6**

Compliance with 12.4.6 is required to meet the requirements of clause E2.3.3 of the NZBC.

**12.4.7 Floor areas subject to watersplash**

Earth floors which meet the surface coating requirements of 12.4.10 may be used in areas of a building that are subject to watersplash if all the following conditions are met:

- (a) The earth floor will not be subjected to a high risk of moisture or contamination, such as within a shower, under or adjacent to a shower tray or bath, or beneath a urinal; and
- (b) The earth floor is not located where leaks in sanitary appliances and their hoses and fittings may result in water reaching the earth floor undetected; and
- (c) The earth floor is not beneath any heavy appliances subject to vibration; and
- (d) The earth floor is not in an area of the building where accidental overflow from a sanitary fixture or sanitary appliance could damage an adjoining household unit or other property (see 2.9.2).

**C12.4.7**

*Earth floors should not be used where they may be subject to direct wetting, such as under or adjacent to a shower base. Earth floors can be serviceable in an area such as a kitchen, laundry, toilet, and non-splash areas of bathrooms, but could be damaged by water from any accidental overflows that cannot be readily detected and mopped up.*

*Dishwashers and washing machines are examples of heavy appliances subject to vibrations.*

*A non-earth floor could be used where leaks in sanitary appliances and their hoses and fittings might occur. The containment and floor waste provisions of paragraphs 2.1.1 and 2.2.1 of E3/AS1 could be used to help prevent water from leaks in sanitary appliances and their hoses and fittings from reaching a nearby earth floor. Grading the surface of the contained floor towards the floor outlet provides further protection to an adjacent earth floor.*

*Any concrete floor adjoining an earth floor may be finished with the surface of the concrete floor reduced by the thickness of any applied finish to give a flush surface. For example, the perimeter of a concrete floor could be set down by the thickness of a waterproof membrane with tile overlay to give a flush surface with the earth floor. It is recommended that any tiled surface be completed before any adjacent earth floor is installed so that the earth floor can be finished at the correct height.*

**12.4.8 Insulation of earth floors****12.4.8.1**

Subfloor insulation under an earth floor may be compacted low-density rock mineral aggregate, or low-density concrete such as air-entrained concrete or pumice-crete. R-values for such a floor will need to be determined by the building designer.

**C12.4.8.1**

*Bottles set in sand, pumice sand, or a pumice/clay mix, or mussel shells have also been used beneath concrete subfloors or floors.*

**12.4.8.2**

Within the scope of this standard, polystyrene of any sort shall not be placed under adobe or pressed brick floors unless there is a minimum of 100 mm of concrete floor over the insulation and under the earth floor topping.

**12.4.8.3**

High-density extruded polystyrene with a minimum compressive strength of 200 kPa and up to 50 mm thick may be used directly under a cob floor. Sand blinded hardfill under this insulation shall be level to within the tolerances shown in 12.4.5(d).

Edge insulation is also shown in Figure 5.10.

#### 12.4.9 Heating pipes

Underfloor water heating pipes or electric heating wires embedded within the body of any earth floors are outside the scope of this standard. Heating pipes may be embedded in reinforced concrete, or over an insulating concrete floor or compacted hardfill substrate, that have an earth floor as an overlay, or embedded in a sand layer under such a floor. Cob floors only may have heating pipes embedded over compacted hardfill within a sand layer with a minimum of 20 mm sand cover over the pipes.

##### **C12.4.9**

*Some heating systems require much less thermal mass than is prescribed in 12.4.9 and require the heating pipes or heating wires to be much closer to the surface of the floor. This has been demonstrated to work in practice with some earthen materials but is outside the scope of this standard. There is also some concern that cracking that can occur naturally in earth floors may put undue strain on embedded heater pipes or wires.*

#### 12.4.10 Surface coatings and sealants

Earth floors shall be sealed after installation to prevent dusting, increase strength, and to provide resistance to penetration by water or other fluids. The surface coating shall be in accordance with NZS 4298 clause 8.14.

#### 12.4.11 Slip resistance

Earth floors with a floated earth plaster finish, or earth brick finishes as moulded or pressed, have slip-resistance characteristics that make them suitable for single unit dwellings.

##### **C12.4.11**

*For commercial applications or other classes of building where specific slip resistance is required then a representative sample will need to be tested in accordance with D1/AS1.*

#### 12.4.12 Maintenance

If the earth floor's surface is damaged it may be repaired by raking out any loose material and repairing using the same techniques as used for the same wall material as per NZS 4298, with the repair being re-oiled once it has dried.

##### **C12.4.12**

*It may be difficult to make a repair blend in with the original floor colour. Inspect the floor on at least an annual basis, and if the surface finish of the floor has become worn it may be given another coat of thinned oil or wax as required.*



## APPENDIX A – BASIS OF ENGINEERING DESIGN

(Informative)

### A1 Design standards and bibliography

The objective of this appendix is to provide the engineering design basis and assumptions used to derive the technical content and design tables in the standard. This information may be useful as the basis of specific engineering designs by professional engineers when called on to provide design solutions that fall outside the scope and limitations outlined in section 1.

The following New Zealand standard codes of practice were used in the preparation of the tables and construction details contained in this standard.

|                    |  |
|--------------------|--|
| AS/NZS 1170 series | Structural design actions                                |
| NZS 3101:2006      | Concrete structures standard                             |
| NZS 3603:1993      | Timber structures standard                               |
| NZS 3604:2011      | Timber framed buildings                                  |
| NZS 4229:2013      | Concrete masonry buildings not requiring specific design |
| NZS 4230:2004      | Design of reinforced masonry structures                  |
| NZS 4297: 2020     | Engineering design of earth buildings                    |
| NZS 4298: 2020     | Materials and construction for earth buildings           |

The following papers were used to develop the wall design strategies for the reinforced earth walls and adobe veneer walls covered by this standard:

Gurumo, S R. *Diagonal Compression Strength of Adobe Wall Panels*. Auckland: University of Auckland, Department of Civil Engineering, 1992.

Liu, Y. *Adobe Performance and Dynamic Response for Seismic Resistance*. Auckland: University of Auckland, Department of Civil and Environmental Engineering, 2013.

Morris, H W, Brooking, J, and Walker, R. 'Out-of-plane adobe wall veneer performance from a novel quasi-static and dynamic tilt test'. *Next Generation of Low Damage and Resilient Structures*. New Zealand Society for Earthquake Engineering Conference 2017. Wellington: 2017

Morris, H, and Walker, R. 'Aseismic Design and Construction of Earth Buildings in New Zealand'. World Conference on Earthquake Engineering. Paper No 2193. Auckland. 2000.

Morris, H W, and Walker, R. 'Fullscale testing of adobe walls'. *Earth Building Association of New Zealand Magazine*, Summer (2018): 6 – 8.

Walker, R and Morris H. 'Development of the New Zealand Building Standards NZS 4297:2020, NZS 4298:2020 and NZS 4299:2020, New Zealand Structural Engineering Society Conference, Hamilton 2021.

Reference was made to BRANZ Engineering Basis of NZS 3604, published by Building Research Association of New Zealand in 2013.

A format similar to that in NZS 3604 and NZS 4229 was adopted for this standard.

### A2 Design strengths, factors, and loads

#### A2.1

A summary of the design strengths, strength reduction factors, and basic loads are shown in tables A1, A2, and A3. Standard grade earth wall construction in accordance with NZS 4297 was assumed.

**Table A.1 – Design strengths (MPa) for standard grade earth wall construction**

|   |                             |
|---|-----------------------------|
| Compressive strength (flexural, direct compression, or bearing)<br>for heavy earth with density from 1400 kg/m <sup>3</sup> to 2200 kg/m <sup>3</sup><br>for light earth with density from 800 kg/m <sup>3</sup> up to 1400 kg/m <sup>3</sup> | $f_e = 0.5$<br>$f_e = 0.35$ |
| Shear strength of steel reinforced earth  | $f_{es} = 0.35$             |
| Tensile/flexural bond strength  | $f_{eb} = 0.02$             |
| Flexural tensile strength   | $f_{et} = 0.1$              |

**Table A.2 – Strength reduction factors**

|                               |               |
|-------------------------------|---------------|
| Flexure                       | $\phi = 0.80$ |
| Shear                         | $\phi = 0.70$ |
| Axial compression and bearing | $\phi = 0.60$ |

**Table A.3 – Basic load data**

|   |                      |
|---|----------------------|
| Light roof and roof structure and ceiling dead load | 0.4 kPa              |
| Light timber partition walls                        | 0.3 kPa              |
| Roof live load                                      | 0.25 kPa             |
| Density of lower density earth wall material        | 14 kN/m <sup>3</sup> |
| Density of heavy earth wall material                | 22 kN/m <sup>3</sup> |

### A3 Structural concept for earth walls

#### A3.1 Earthquake zones

Earthquake zones were allocated numbers similar to NZS 3604.

Three earthquake zones were adopted in this standard with the following factors for the determination of seismic loads:

Earthquake zone 1,  $Z = 0.2$

Earthquake zone 2,  $Z = 0.3$

Earthquake zone 3,  $Z = 0.46$

Earth buildings in earthquake zone 4 are outside the scope of NZS 4299

#### A3.2 Soil classes

NZS 1170.5 provides for five soil classes:

A – strong rock, B – rock, C – shallow, D – soft, and E – very soft. These classes result in a difference in demand for earth buildings of about 1.6 times highest to lowest, and this has been provided for in section 4 of NZS 4299.

Table 4.2 – Site earthquake factor for the calculation of earthquake bracing demand provides for three different earthquake zones and three different site subsoil classes with soil classes D and E combined similar to NZS 3604.

#### A3.3 Horizontal design action coefficient

The horizontal design action coefficient  $C_d(T_1)$  is given as:

$$C_d(T_1) = C(T_1) \times S_p/k_\mu$$

where

$S_p$  = structural performance factor = 0.9 for earth walled buildings with ductility of 1.25

$k_{\mu}$  = inelastic spectrum scaling factor, dependent on building period and soil class (For  $T \leq 0.4$  sec, its value is 1.14 for class A to D soils and 1.25 for class E soils).

$$C(T) = C_h(T) Z R N(T,D)$$

$C_h(T)$  = spectral shape factor, dependent on building period and soil class:

For  $T \leq 0.4$  sec, the value of  $C_h(T)$  is:

1.89 for class A and B soils,

2.36 for class C soils,

3.0 for class D and E soils.

$Z$  = hazard factor as described in hazard maps in AS/NZS 1170

$R$  = return period factor at ULS (= 1.0 for importance level 2 buildings covered by NZS 4299)

$N(T,D)$  = near-fault factor (1.0 for building period  $\leq 0.4$  sec)

The ductility factor ( $\mu$ ) used to derive  $k_{\mu}$  was 1.25, as discussed and agreed by the New Zealand Earth Buildings standards development committee. This value is recommended to be used where equivalent specific designs are being undertaken for earth walled buildings outside the scope of NZS 4299.

Using the parameters above, the lateral force coefficient ( $C$ ) for the relevant soil classes and seismic zones may be tabulated as follows:

**Table A.4 – Site earthquake factor**

| Soil class | Earthquake zone |      |      |
|------------|-----------------|------|------|
|            | 1               | 2    | 3    |
| A and B    | 0.30            | 0.45 | 0.69 |
| C          | 0.37            | 0.56 | 0.86 |
| D and E    | 0.47            | 0.71 | 1.09 |

#### A3.4 Design for earthquake and wind loads

Designing for earthquake loading was generally assumed to be more critical than designing for wind for the wind exposure limitations imposed in this standard particularly for heavy earth with density of 1400 kg/m<sup>3</sup> to 2200 kg/m<sup>3</sup>. The calculation of bracing demand requires that the bracing demand for wind be checked to determine whether either earthquake or wind incurs the greater bracing demand.

#### A3.5 Design of earth walls

Earth walls were designed as spanning between the reinforced concrete foundation at the bottom of the wall and the top plate or bond beam at the top of the wall. Loads from tops of walls, and light roofs were assumed to be distributed by concrete or timber bond beams or structural ceiling or roof or diaphragms to transverse earth bracing walls.

#### A4 Bond beam span tables derivations

Bond beams were designed for the lateral forces imposed by both wind and earthquake, using the tributary roof and wall loads generated by each of those actions. For light earth in the very high wind areas, it was found that wind actions were greater than those of earthquakes.

Bond beam spans were limited to 6.0 m for two reasons:

- 6.0 m is the maximum spacing between bracing lines allowed in this standard;
- 6.0 m is the maximum length of commonly available sawn timber.

#### A5 Lintel span tables derivations

Lintel span tables were calculated using the load cases of AS/NZS 1170.0 clause 4.2.2.

For side walls a maximum of 300 mm earth was assumed over the top of the lintel. For earth gable end walls the maximum height of the gable was as per 1.2.

The loaded roof dimension for an exterior side wall lintel was 5.53 m, made up of half a 8.0 m internal truss and half a 3.05 m wide external verandah. For gable end wall the loaded roof dimension was half of a 3.05 m verandah, that is 1.53 m.

## A6 Internal adobe veneer walls (Appendix F)

### A6.1

Reference was made to the BRANZ publication *Engineering Basis of NZS 3604* for the design of the timber studs supporting the adobe veneer walls.

### A6.2

The ductility factor ( $\mu$ ) used in NZS 3604 was 3.5. A more conservative ductility factor of 2 was used for the design of the timber studs supporting the adobe veneer walls in Appendix F Internal adobe veneer walls and for the calculations for the stud sizes and spacings in Tables F.1 and F.2.

### A6.3

For simplicity for the calculations for the Tables F.1 and F.2, the most conservative soil class E was used for the derivation of horizontal design action coefficient for the design of the timber studs supporting the adobe veneer walls.

### A6.4

Allowance was made for the additional weight of light wall cladding not exceeding 30 kg/m<sup>2</sup> on the other side of the adobe veneer wall and of 15 kg/m<sup>2</sup> for the studs in addition to the weight of the adobe veneer wall for the design of the studs in Tables F.1 and F.2.

### A6.5

The maximum allowable deflection for the studs in Tables F.1 and F.2 was span/180 assuming that the modulus of elasticity for the SG8 studs was 6.7 GPa. This is conservative compared with NZS 3604 where 9.13 GPa was used for the design of studs with a maximum deflection of span/180. The bending strength used for the design of the SG8 studs was 14 MPa.

### A6.6

The connections of the studs to the timber bottom plate and timber top plate, Types A and B, provide for horizontal loads more than twice the calculated earthquake loads at the top and bottom of the studs.

### A6.7

The site earthquake factors,  $K_e$ , for calculating the additional wall bracing demand for adobe veneer walls for the different earthquake zones 1, 2, and 3 and soil classes A, B, C, D, and E are the same as those used for calculating the earthquake demand in section 4 of NZS 4299 assuming nominal ductility.

## A7 Seismic lateral force coefficients for adobe veneer walls

### A7.1 Seismic lateral force coefficients

Seismic lateral force coefficients from Appendix F are determined from NZS 1170.5 elastic site hazard spectrum:

$$C(T) = C_h(T) Z R N(T,D)$$

### A7.2 For earthquake zone 1

The horizontal design action coefficients in earthquake zone 1 for various soil classes is derived from the BRANZ publication *Engineering basis of NZS 3604* and Table 3.3 of NZS 1170.

For zone 1,  $Z = 0.2$  for strong rock and rock.

(a) For soil class A and class B from Table 3.1 NZS 1170, for class B soil,  $T < 0.4$ ,  $C_h(T) = 1.89$

From Table 3.5 of NZS 1170, for 1/500 year event,  $R = 1.0$  site more than 20 km from nearest fault and the structure period is less than 1.5 s, from clause 3.1.6 of NZS 1170, near fault factor is:  $N(T,D) = 1.0$  therefore,

$$C(T) = 1.89 \times 0.2 \times 1.0 \times 1.0 = 0.378$$

Horizontal design action coefficient

$$C_d(T_1) = C(T_1) \times S_p/k_\mu$$

BRANZ publication *Engineering basis for NZS 3604* utilises structural performance factor  $S_p = 0.7$  with ductility of 3.5.

For design of studs for adobe veneer walls use more conservative ductility of 2.

$$k_\mu = ((\mu - 1)T_1/0.7) + 1, \text{ use } T_1 = 0.4$$

for elastic structure,  $\mu = 1$ ,  $k_\mu = 1$

for nominally ductile structure,  $\mu = 1.25$ ,  $k_\mu = 1.14$

for limited ductile structure as per NZS 4299 Appendix A,  $\mu = 2$ ,  $k_\mu = 1.57$

Use limited ductile structure, that is  $\mu = 2$ ,  $k_\mu = 1.57$

Horizontal design action coefficient,  $C_d(T_1) = 0.378 \times 0.7/1.57 = 0.17$

(b) For shallow soil, class C,

from Table 3.1 NZS 1170, for Class C soil,  $T < 0.4$ ,  $C_h(T) = 2.36$  therefore:  
 $C(T) = 2.36 \times 0.2 \times 1.0 \times 1.0 = 0.472$

horizontal design action coefficient,  $C_d(T_1) = 0.472 \times 0.7/1.57 = 0.21$   
 similarly for deep or soft soil,

(c) For class D and very soft class E from Table 3.1 NZS 1170, for class D and E soils,  $T < 0.4$ ,  $C_h(T) = 3.00$   
 therefore  $C(T) = 3.0 \times 0.2 \times 1.0 \times 1.0 = 0.60$

horizontal design action coefficient,  $C_d(T_1) = 0.60 \times 0.7/1.57 = 0.27$

for simplicity for tables for studs for adobe veneer assume worst case with class D and E soils.

therefore, horizontal design action coefficient,  $C_d(T_1) = 0.27$

### A7.3 For earthquake zone 2

The horizontal design action coefficients in earthquake zone 2 for various soil classes is derived from the BRANZ publication *Engineering basis of NZS 3604* and Table 3.3 NZS 1170.

For zone 2,  $Z = 0.3$

For class D and class E soils.

From Table 3.1 NZS 1170, for class D and E soils,  $T < 0.4$ ,

$C_h(T) = 3.00$  therefore,

$$C(T) = 3.0 \times 0.3 \times 1.0 \times 1.0 = 0.90$$

horizontal design action coefficient,

$$C_d(T_1) = 0.90 \times 0.7/1.57 = 0.40$$

### A7.4 For earthquake zone 3

The horizontal design action coefficients in earthquake zone 3 for various soil classes is derived from the BRANZ publication *Engineering basis for NZS 3604* and Table 3.3 NZS 1170.

For zone 3,  $Z = 0.46$

For class D and class E soils

From Table 3.1 NZS 1170, for class D and E soil,  $T < 0.4$ ,

$C_h(T) = 3.00$  therefore,

$$C(T) = 3.0 \times 0.46 \times 1.0 \times 1.0 = 1.38$$

horizontal design action coefficient,

$$C_d(T_1) = 1.38 \times 0.7/1.57 = 0.62$$

**A7.5 For earthquake zone 4**

Earthquake zone 4 is outside the scope of the standard and requires SED.

DRAFT

APPENDIX B – WORKED EXAMPLE

(Informative)

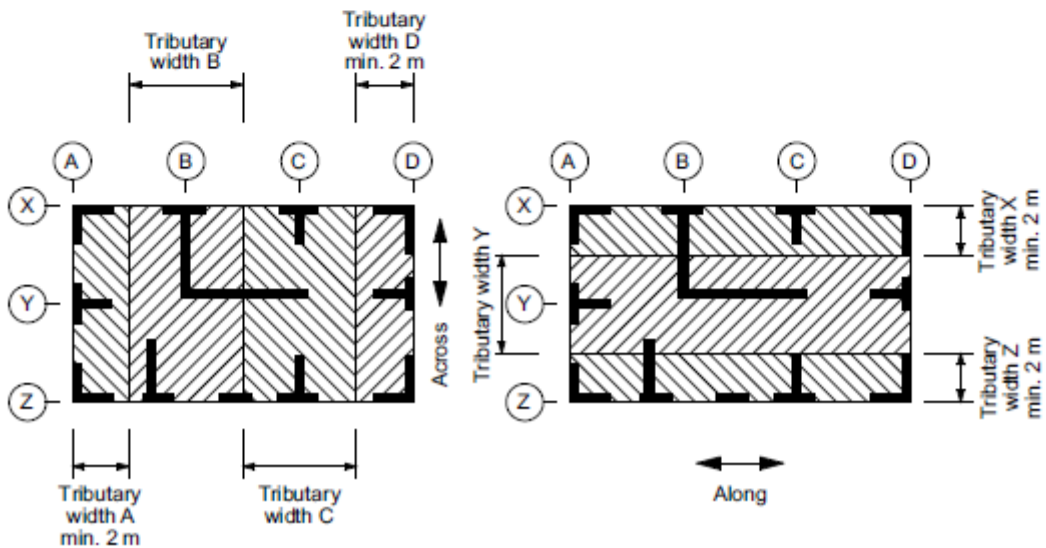
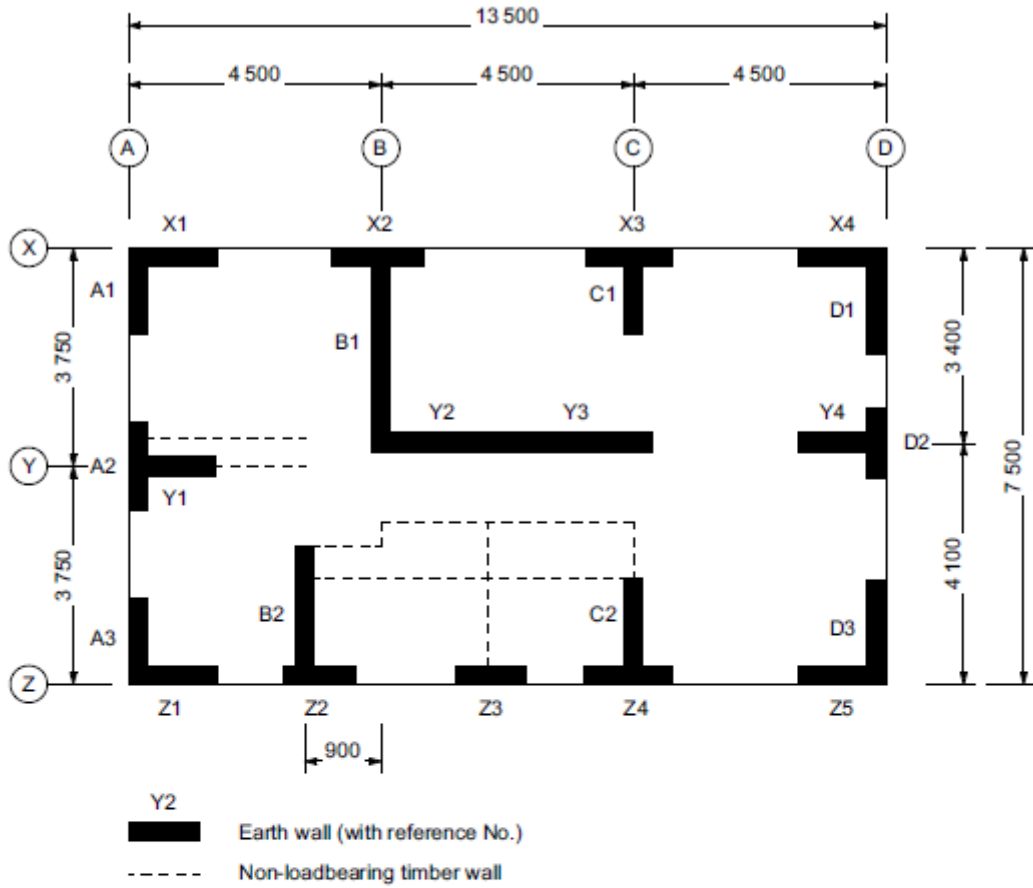

Figure B.1 – Example building 1

**Table B.1 – Calculation of earthquake bracing demand example**

Example NZS 4299 B1, building with heavy adobe walls

Refer to 4.2.4 for the calculation of earthquake bracing demand.

| STEP | CLAUSE    | DESCRIPTION  | CALCULATION            |
|------|-----------|--|------------------------|
| 1    | 4.2.1     | Seismic subsoil category (determined by SED)   | 2                      |
| 2    | 4.2.2     | Earthquake zone for building location 2  | C                      |
| 3    | 4.2.3     | Site earthquake factor (refer to Table 4.2)  | 0.56                   |
| 4    | 4.2.4 (a) | Density of earth wall material (from test in NZS 4298)                               | 1700 kg/m <sup>3</sup> |
| 5    | 4.2.4 (b) | Volume of earth walls above mid-height of wall                                       | 14.58 m <sup>3</sup>   |
| 6    | 4.2.4 (c) | Weight of earth walls above mid-height of wall (item 4 × item 5)                     | 24 786 kg              |
| 7    | 4.2.4 (d) | Area of light weight roof  | 128.00 m <sup>2</sup>  |
| 8    | 4.2.4 (e) | Weight of roof = item 7 × 45 (kg)  | 5760 kg                |
| 9    | 4.2.4 (f) | Length of internal timber partition walls  | 10 m                   |
| 10   | 4.2.4 (g) | Weight of internal timber partition walls = (10 × 2.7 ÷ 2) × 30                      | 405 kg                 |
| 11   | 4.2.4 (h) | Total weight of building above mid-height of walls = items 6 + 8 + 10                | 30,951 kg              |
| 12   | 4.2.4 (i) | Earthquake horizontal force at top plate level = item 11 × item 3                    | 17,333 kg              |
| 13   | 4.2.4 (i) | Earthquake bracing demand (BU) = item 12 × 0.2                                       | 3467 BU                |
| 14   | 4.3       | Wind zone  | Very high              |
| 15   | 4.3       | Wind bracing demand across from NZS 3604 Table 5.2 = 72 BU/m                         | 972 BU                 |
| 16   | 4.3       | Wind bracing demand along from NZS 3604 Table 5.2 = 72 BU/m                          | 540 BU                 |
| 17   | 4.4       | Design bracing demand (greatest demand in each direction)                            | 3467 BU                |
| 18   |           | Earthquake bracing demand greater than wind  |                        |
| 19   | 4.2.4 (k) | Earthquake bracing demand = 3467 ÷ (13.5 × 7.5) (rounded up to nearest whole number) | 35 BU/m <sup>2T</sup>  |

Notes for calculation of volume of earth walls above mid-height of wall:

Total length of earth walls from floor plan of building = 36 m

Height of earth walls = 2.7 m

Thickness of earth walls = 300 mm

Volume of earth walls = 36 × 2.7 × 0.3 = 29.16 m<sup>3</sup>Volume of earth walls above mid-height of wall = 29.16 ÷ 2 = 14.58 m<sup>3</sup>

(assumes no earth wall above openings)

BUs demand for Line A = tributary length × tributary width = 7.5 × 2.25 × 35 = 591

BUs demand or Line B = tributary length × tributary width = 7.5 × 4.5 × 35 = 1181



Table B.2 – Detailed wall bracing capacity calculations for example NZS 4299 B1 building

| Wall / bracing line   | Total wall length (m) | Tributary width (m) | BUs demand  | 70% of BUs | Wall ref No. | Wall length | Capacity BUs | Totals                           | Notes     |
|-----------------------|-----------------------|---------------------|-------------|------------|--------------|-------------|--------------|----------------------------------|-----------|
| <b>North-South</b>    |                       |                     |             |            |              |             |              |                                  |           |
| A                     | 7.5                   | 2.25                | 591         |            | A1           | 1.5         | 309          | 927                              | OK        |
|                       |                       |                     |             |            | A2           | 1.5         | 309          |                                  |           |
|                       |                       |                     |             |            | A3           | 1.5         | 309          |                                  |           |
|                       |                       |                     |             |            | <b>Total</b> | <b>4.5</b>  | <b>927</b>   |                                  |           |
| B                     | 7.5                   | 4.5                 | 1181        | 827        | B1           | 3.6         | 798          | 1333                             | OK        |
|                       |                       |                     |             |            | B2           | 2.4         | 535          |                                  |           |
|                       |                       |                     |             |            | <b>Total</b> | <b>6</b>    | <b>1333</b>  |                                  |           |
| C                     | 7.5                   | 4.5                 | 1181        | 827        | C1           | 1.5         | 309          | 693                              | NOT OK    |
|                       |                       |                     |             |            | C2           | 1.8         | 384          |                                  |           |
|                       |                       |                     |             |            | <b>Total</b> | <b>3.3</b>  | <b>693</b>   |                                  |           |
|                       |                       |                     |             |            |              |             |              | <b>(Make C2 =2.4 m BUs =535)</b> |           |
| D                     | 7.5                   | 2.25                | 591         |            | D1           | 1.8         | 384          | 768                              | OK        |
|                       |                       |                     |             |            | D2           | 1.2         | 0            |                                  |           |
|                       |                       |                     |             |            | D3           | 1.8         | 384          |                                  |           |
|                       |                       |                     |             |            | <b>Total</b> | <b>4.8</b>  | <b>768</b>   |                                  |           |
| <b>Total capacity</b> |                       |                     |             |            |              |             |              | <b>3721</b>                      |           |
| <b>Total demand</b>   |                       |                     | <b>3544</b> |            |              |             |              |                                  | <b>OK</b> |
| <b>East-West</b>      |                       |                     |             |            |              |             |              |                                  |           |
| X                     | 13.5                  | 2                   | 945         |            | X1           | 1.5         | 309          | 1236                             | OK        |
|                       |                       |                     |             |            | X2           | 1.5         | 309          |                                  |           |
|                       |                       |                     |             |            | X3           | 1.5         | 309          |                                  |           |
|                       |                       |                     |             |            | X4           | 1.5         | 309          |                                  |           |
|                       |                       |                     |             |            | <b>Total</b> |             | <b>1236</b>  |                                  |           |
| Y                     | 13.5                  | 3.75                | 1772        | 1240       | Y1           | 1.5         | 309          | 1688                             | OK        |
|                       |                       |                     |             |            | Y2           | 2.4         | 535          |                                  |           |
|                       |                       |                     |             |            | Y3           | 2.4         | 535          |                                  |           |
|                       |                       |                     |             |            | Y4           | 1.5         | 309          |                                  |           |
|                       |                       |                     |             |            | <b>Total</b> |             | <b>1688</b>  |                                  |           |
| Z                     | 13.5                  | 2                   | 945         |            | Z1           | 1.5         | 309          | 927                              | OK        |
|                       |                       |                     |             |            | Z2           | 1.2         | 0            |                                  |           |
|                       |                       |                     |             |            | Z3           | 1.2         | 0            |                                  |           |
|                       |                       |                     |             |            | Z4           | 1.5         | 309          |                                  |           |
|                       |                       |                     |             |            | Z5           | 1.5         | 309          |                                  |           |
|                       |                       |                     |             |            | <b>Total</b> |             | <b>927</b>   |                                  |           |
| <b>Total capacity</b> |                       |                     |             |            |              |             |              | <b>3851</b>                      | <b>OK</b> |
| <b>Total demand</b>   |                       |                     | <b>3662</b> |            |              |             |              |                                  |           |

Check for clause 6.3.9. OK

Therefore, proposed wall bracing is satisfactory if wall C2 increased from 1.8 to 2.4 m long.

THERE IS NO APPENDIX C

DRAFT

## APPENDIX D – LIGHT EARTH METHOD OR LEM

(Informative)

### C Appendix D

*'Informative' appendix means it is for information and guidance only. It is therefore not mandatory and does not provide a complete means of compliance with the NZBC. A conservative, cautious stance has been taken on topics where there is not a considerable service history with a variety of materials in a variety of climatic environments.*

### D1 General

This appendix provides both prescriptive and performance-based requirements for the use of LEM as a building material within a structural timber framework. It may act as a guide for practitioners and building officials when assessing the use of LEM as an alternative solution to achieve compliance with the NZBC.

#### CD1

*The LEM acts as thermal insulation placed as in-situ infill between the structural members in a double stud or thicker single stud timber-framed wall.*

*It may also help provide some acoustic insulation between rooms in a single dwelling.*

*With light earth any damage or failure of the water-shedding lime plaster or other cladding doesn't automatically effect the structural integrity of the dwelling if remedial work is carried out.*

*Clay in the LEM mix reduces the equilibrium moisture content of adjacent timber and fibres in the wall, and this, along with water vapour permeable plaster systems kept relatively sheltered from wind-driven rain, promotes drying, thereby enabling direct plastered walls systems to perform well.*

*There is an overlap between low-density earth at 800 kg/m<sup>3</sup> to 1400 kg/m<sup>3</sup> and LEM at 200 kg/m<sup>3</sup> to 1200 kg/m<sup>3</sup>, however they are different materials with different purposes.*

### D2 Scope and exclusions

#### D2.1 Scope

This appendix covers the use of LEM insulation infill to form non-loadbearing walls set within a timber structural frame that is subject to SED.

The scope of coverage includes:

- (a) Earthquake zones 1, 2, and 3 as defined in 4.2.2 and all subsoil classes as defined in 4.2.1;
- (b) Single storey;
- (c) Maximum wall height 3.6 m;
- (d) LEM infill width 150 mm minimum to 300 mm maximum;
- (e) Wind zones from low (L) to very high (VH) in accordance with NZS 3604.

#### D2.2 Scope exclusions

The following are not within the scope of this appendix:

- (a) Panelised or prefabricated LEM systems;
- (b) Structural design of LEM walls, including foundations and bracing;
- (c) Loadbearing LEM material in walls;
- (d) LEM used below finished ground level, in subfloor areas, or in exterior parapet walls;
- (e) Exterior LEM walls that are not vertical.

### D3 Definitions

|                            |  |
|----------------------------|--|
| <b>Clay slip or slurry</b> | A suspension of creamy consistency of clay particles in water  |
| <b>Infill LEM</b>          | Insulation mixture that is placed between the structural members of a building.  |
| <b>Monolithic</b>          | A continuous wall without articulated joints.  |
| <b>Straw</b>               | The dry stems of cereal grains after and/or seed heads have been substantially removed of wheat, rice, rye, barley, or oats. |
| <b>Plastering</b>          | Plastering is the mixing, application, and curing of plaster or render on a substrate.                                       |

### D4 Non-loadbearing LEM construction

#### D4.1 Materials

##### D.4.1.1 Straw, cellulose materials, or light mineral aggregates

Straw should be the stalks of wheat, rye, oats, rice, or barley, and should be free of visible decay and insects. Alternative cellulose materials such as durable species of wood shavings or sawdust, reeds, or hemp shiv may be substituted for straw.

Cellulose fibre may also be included.

Pea straw, hay, or other grasses or fibres containing leaf matter and/or seeds should not be used.

If a mineral-only LEM mix is desired, pumice, vermiculite, or scoria in a well-graded mix of particle sizes should be used.

##### D.4.1.2 Earth

Earth used for the clay slip in the LEM mix should be a mix of clay, silt, and sand, and have a minimum clay content sufficient to bind the LEM mix particles together.

##### CD4.1.2

*One method for checking clay content is by forming a nominal 300 mm × 300 mm × 150 mm test brick that passes the drop test in NZS 4298 Appendix F when dry. This test is suggested as one method to give assurance about the robustness of the material's cohesiveness. It is not required for materials that are to have a plastered timber lath or permanent formwork over them.*

*The drop test (or some other agreed robustness test) may be done by the owner or the owner's representative, or by an accredited laboratory on a minimum of three samples. Record the results and provide copies to the building consent authority or local authority on request.*

*A suitable minimum clay content is not easy to define but the earth used should at least pass the ball test NZS 4298 Appendix B.*

##### D.4.1.3 LEM mix

All straw or other fibres or aggregates should be mixed with clay slip until they are thoroughly and evenly coated to form a homogeneous mix with no pockets of dry material.

The mix is adjusted with the volume of straw and/or other fibres to reduce shrinkage from wet tamped to dry of 0.5% (shrinkage test NZS 4298 Appendix H).

##### CD4.1.3

*Soaking any fibrous material will saturate it and make drying take much longer than a freshly made surface-coated only mix, and will also add extra moisture into the supporting timber frame, and is not recommended.*

##### D4.1.4 LEM thickness

The LEM component in a wall should be between 150 mm and a maximum of 300 mm thick, and of even density to ensure even distribution of loads within the wall system.

**CD4.1.4**

*Thicker walls may take a long time to dry out and can then support fungal or mould growth. Building with LEM can also be slow to dry at times of high humidity and low wind, or during winter.*

**D4.1.5 Density**

LEM should have a minimum dry density greater than 200 kg/m<sup>3</sup> and a maximum density less than 1200 kg/m<sup>3</sup>.

The dry density should be calculated by the method given in NZS 4298 Appendix M.

Cast samples should be prepared that are a minimum of 0.25 m × 0.25 m × 0.15 m (250 mm × 250 mm × 150 mm). Sample weight will be measured in kilograms, after the sample has been oven dried. Units will be kg/m<sup>3</sup>.

Not less than five samples of LEM should be used should be tested for density, and an average taken.

**CD4.1.5**

*The target density that is used depends on the position of the wall and whether its primary function is insulation or heat storage/acoustic insulation.*

*Densities below 350 kg/m<sup>3</sup> are possible to make but they can lack the strength to be able to withstand external face loads on a wall when direct plastered but are possible between laths or formwork that remains permanently in place. By using a timber lath or permanent formwork to support the plaster these lower density materials may be used.*

*Density tests may be done by the owner or the owner's representative, or by an accredited laboratory. Record the results and provide copies to the building consent authority or local authority on request.*

**D5 Structure****D5.1 Framing**

If the mass of the LEM is less than 300 kg/m<sup>2</sup> then the light timber framing for LEM may be designed to be in accordance with [F5 in Appendix F Internal Adobe Veneer](#). If this design method is used then the studs for the timber framing should be in accordance with Table 12.1 if the mass of the LEM is less than 220 kg/m<sup>2</sup>, and in accordance with [Table F.1](#) if the mass of the LEM is greater than 220 kg/m<sup>2</sup> but less than 300 kg/m<sup>2</sup>. Clause [F5.2](#) may also apply for LEM walls in high or very high wind zones.

A light timber-framed building or post and beam structure may also be designed in accordance with SED.

**CD5.1**

*Although NZS 3604 allows for a heavy cladding with mass of up to 220 kg/m<sup>2</sup> of wall, checking the mass per m<sup>2</sup> is required to determine which option of D5.1 applies:*

- (a) At 200 kg/m<sup>3</sup> and 300 mm thick the mass of the LEM in a wall is 60 kg/m<sup>2</sup>;*
- (b) At 400 kg/m<sup>3</sup> and 300 mm thick the mass of the LEM in a wall is 120 kg/m<sup>2</sup>;*
- (c) At 700 kg/m<sup>3</sup> and 300 mm thick the mass of the LEM in a wall is 210 kg/m<sup>2</sup>;*
- (d) At 800 kg/m<sup>3</sup> and 300 mm thick the mass of the LEM in a wall is 240 kg/m<sup>2</sup>;*
- (e) At 1200 kg/m<sup>3</sup> and 200 mm thick the mass of the LEM in the wall is 240 kg/m<sup>2</sup>.*

**D5.2 Bracing**

Wind and seismic bracing should be in accordance with SED.

**CD5.2**

*Some engineers have ascribed a conservative 30 BUs/m to the bracing capacity of LEM walls. Some tests have reported results three to four times that value to LEM walls plastered on both faces, but any particular value is dependent on a wide range of factors, so ascribing any bracing capacity to LEM walls is subject to SED.*

*Walls with LEM infill should not be directly sheathed with solid sheet bracing materials such as water vapour permeable ply or magnesium oxide board for bracing as this may inhibit drying, unless they are used on internal surfaces of walls, or behind cavities, and/or sheets have a permeance of less than 290 SI permeance units,*

*and are permanently fitted only after the wall framing adjacent to the LEM is dry with an equilibrium moisture content less than 16%. For further information on permeance and SI units see NZS 4298 section 8.5.4 and C8.5.4*

### D5.3 Wall support

#### D5.3.1 Bottom plates

Timber bottom plates that are a minimum of 45 mm × 90 mm and either the full width of the framing above or, for wider walls, one each side of the wall set flush with each face of the framing above and with a gap between may be used. These should be supported on a foundation designed to NZS 3604 if applicable or to SED.

Anchoring should comply with F.6.1 to F.5.4 if applicable or to SED.

The outer plate under a LEM wall may overhang the foundation the thickness of any exterior perimeter insulation over the footing below, but in no case greater than 50 mm, and the width of the bottom plate increased to accommodate the width of the overhang. There needs to be a minimum of 90 mm bearing on the concrete footing and sufficient clearance provided between the anchor bolt and the edge of the concrete.

#### CD5.3.1

*The bottom plates are provided to lift the bottom of the LEM a minimum of 45 mm above floor level to keep the material dry in case of water getting onto the floor during construction or in service, to create a thermal break from any concrete foundations, and to provide fixing for mesh and plaster stops, and fastening for diagonal bracing. See D6.1.*

#### D5.3.2 Wall reinforcing

Timber studs or vertical parallel chord trusses should be secured to top and bottom plates as required by SED or NZS 3604 sections 8 and 10.

Vertical timber framing and plates that penetrate the full thickness of the LEM wall should either be placed in such a way to provide keying between the timbers and LEM or have an ex 45 mm × 45 mm batten attached to provide a key to the LEM infill.

#### CD5.3.2

*Vertical framing reinforces the LEM mix in the wall as well as providing structure. Framing is set out to accommodate the light earth mix, either by posts or poles or studs the full width of the walls, double studs off set or blocked together, or made up into a vertical truss. One particular vertical truss often used is sometimes described as a Larsen truss.*

*See diagrams of typical framing patterns included at end of this appendix.*

#### D5.3.3. Horizontal reinforcing

Horizontal reinforcing or stabilising rods for the LEM infill should be installed at 600 mm maximum centres in earthquake zones 1 and 2 and 450 mm maximum centres in earthquake zone 3 and be slotted between rows of vertical members.

Reinforcing rods may be of any of the following minimum sizes: 20 mm diameter bamboo, 12 mm diameter fibreglass rod, 25 mm diameter wood dowels, timber slats 19 mm × 19 mm or 19 mm × 35 mm minimum.

#### CD5.3.3

*These rods should be able to slide downwards vertically as the LEM dries and not move sideways. They should be placed horizontally and a minimum of 50 mm above any horizontal blocking, and with wall material carefully placed around them, to prevent 'hang up' and cracking in such a way that allows for shrinkage as the LEM dries.*

*Contain the rods horizontally at 1800 mm centres maximum with blocks, or within rebates at end plates at least 25 mm deep or run through slotted holes or cut-outs to ensure that they will not slip sideways within the walls.*

*Where horizontal rods cross at corners or wall intersections, take the rods as far as practicable past each other and securely tie together with polypropylene baling twine.*

#### D5.3.4 Diagonal reinforcing

Timber or metal strap diagonal reinforcing may be installed as required by SED within the walls.

**CD5.3.4**

*When designing diagonal bracing, and when placing LEM material, recognise that there may be a risk of LEM material hanging up on any embedded horizontal or diagonal members as the LEM material shrinks or settles as it dries. This can be avoided by careful placing of the material within the walls around such elements.*

**D5.3.5 LEM formwork**

Formwork should be sufficiently strong to resist bowing when the LEM mix is tamped inside the forms.

**CD5.3.5**

*Generally, this formwork is 12 mm ply or thicker temporarily screwed to the outer surfaces of the studs. One side of the wall may have boxing installed full height while the other is progressively added in lifts to allow access to place and tamp the LEM mix.*

**D5.3.6 Placing LEM**

Form work should be uniformly loaded with LEM and should be evenly tamped to achieve stable, monolithic walls that are free of voids.

LEM should be installed in lifts of no more than 150 mm of loose material at a time and should be thoroughly tamped before additional material is added.

**CD5.3.6**

*The mix is thoroughly tamped when it will feel like it rebounds slightly or feels a little bit spongy when pushed down by hand.*

*To eliminate voids, pay particular attention to tamping corners or material adjacent to any structural members.*

*LEM should not be placed when there is a risk of the material freezing.*

**D5.3.7 Removal of formwork**

Formwork should be removed from walls within 12 hours maximum after tamping, and walls should remain exposed to air movement but protected from wetting until dry.

**CD5.3.7**

*Do not wrap the walls tightly for weather protection as air movement is critical to facilitate drying.*

**D5.3.8 Cold joints**

Whenever a wall is not continuously built, the top of the previous LEM mix should be moistened and thoroughly coated with clay slip prior to the application of a new layer of LEM while the slip is still moist.

**D6 Moisture****D6.1 Damp-proof course (DPC)**

A sheet or liquid applied DPC should be applied over the top of the concrete or masonry foundation the full width of the wall beneath the bottom plates.

Any void between pairs of bottom plates should be filled flush with timber, solid insulation, or a material that is water resistant yet allows vapour dispersion.

**CD6.1**

*Vapour-dispersing infill material between the plates can include insulating mineral fill such as timber, coarse pumice sand or scoria, or pea gravel.*

*Insulation is important to prevent the formation of a cold surface against the LEM that condensation may form on. Extruded polystyrene may be a suitable void filler. Mineral filler is often used, as the air gaps make it less cold than solid concrete and any moisture formed can drain away from the LEM/void filling interface. The gap between bottom plates is not to be ventilated to exterior atmosphere.*

**D6.2 Separation of LEM and timber**

A damp-proof membrane (DPM) is not required between timber in structural or non-structural members in exterior and interior walls in direct contact with and LEM.

Naturally durable timber or timber treated to hazard class H1.2 minimum or its equivalent should be used in contact with LEM.

**CD6.2**

*Some practitioners paint timber that will be in contact with LEM with asphaltic or other paint to lessen uptake of moisture into the timber frames, thereby allowing quicker construction by reducing the moisture uptake in timber members that otherwise needs to dry out before linings can be fixed.*

**D6.3 Separation of other structural members**

Structural members that are not timber and are in contact with LEM in exterior walls should be resistant to corrosion or coated to prevent corrosion with an approved coating.

**D6.4 Separation of LEM and concrete**

LEM should not be laid directly up to, or against, a concrete or concrete masonry or fired brick masonry retaining or exterior wall.

LEM should be separated from concrete and masonry in any other situation by a timber plate over a DPC, or by a clear gap of not less than 20 mm.

Any air gap should either be drained and ventilated, and the hidden LEM surface covered with 10 mm minimum earth or lime plaster (see NZS 4298 section 8 Surface coatings), or the gap may be filled with an insulating material such as wood or rigid insulation with a permeance greater than 300 SI units.

**CD6.4**

*This requirement is to separate LEM walls from poorly insulated or cold surfaces that might be a source of moisture condensation.*

**D6.5 Temporary support of LEM walls during construction**

Temporary bracing of LEM walls may be required during construction.

**D6.6 External and internal moisture control**

LEM walls need to be protected from moisture, water intrusion, and damage.

**D6.6.2 Surface moisture**

The bottom of the LEM should be separated from finished ground level by not less than 270 mm or 195 mm to permanent paving.

**CD6.6.2**

*There is a risk of splash-back from rain if finished ground levels are less than these.*

*The requirements of D5.3.1 and the commentary in CD5.3.1 mean that the actual bottom of the LEM is at least 45 mm above the finished floor level.*

**D6.6.3 Separation of exterior plaster and finished ground level**

Exterior plaster should be located not less than 175 mm above finished ground level or 100 mm above permanent paving or adjoining deck surfaces.

**D6.6.4 Moisture content**

LEM walls should be dry to a maximum equilibrium moisture content of 18% at a depth of 100 mm, as measured from each side of the wall in the abutting adjacent timber structure, prior to the application of plaster finish on either side of the wall.

Moisture content should be measured with an approved moisture meter or by other approved means.

LEM that shows any signs of mould should be removed from the building site.



**CD6.6.4**

*The addition of colloidal copper or other fungal inhibitor such as boric acid or other fungicide to mixing water can be considered if drying might be prolonged in wall mixes that contain plant-based fibres.*

*Any initial signs of surface mould or fungus may be treated in situ with a fungicide such hydrogen peroxide or a weak sodium hypochlorite (household bleach) solution.*

*Alternatively, a mineral only mix of LEM may be considered, whereby clay blinder is replaced with lime putty. Such a method is outside the scope of this standard.*

**D6.6.5 Exterior cladding risk matrix**

The building envelope risk matrix, Table D1, may be used to determine whether walls should be suitable for direct plaster cladding, or should need a rain-screen cladding over a cavity system or other weather protective measures.

The design of cavity battens over LEM walls that support other weather protective cladding is outside the scope of this standard and is subject to SED.

**CD6.6.5**

*The biggest risk factor from external moisture that LEM walls encounter is that posed by wind-driven rain. The publication 'External moisture – An introduction to weathertightness design principles', available on MBIE's building performance website [www.building.govt.nz](http://www.building.govt.nz), provides a clear explanation of the basis on which good weathertight buildings can be constructed in New Zealand.*

*Determining what constitutes the amount of exposure to wind-driven rain that will give reliable durability for direct plastered LEM wall or otherwise determining when a cavity may be required is not simple.*

*Plaster over LEM walls can absorb moisture but needs to be able to dry out fast enough (after absorption), before the integrity of the plaster or LEM is damaged. Therefore assessing the risk from wind-driven rain that a wall is exposed to is an important design consideration.*

*The risk matrix is one tool that can be used to help determine whether a cavity is required or not. It is weighted towards the conservative and its main application will be in areas of the country, and especially on exposed sites, that are subject to high annual rainfall and/or to frequent episodes of wind-driven rain.*

*Additional reduction risk factors are given to the score after an assessment is made of a range of factors specific to any site sheltering features such as the effects of local geographic or landscaping features on any particular aspect of a building and exposure to wind-driven rain.*

*Assessments can be made of the known direction of wind-driven rain particular to that site, the direction of severe storms on each aspect of the building, and the annual rainfall data and its localised directions and risk adjusted accordingly.*

*If a particular site is known to only receive very minor amounts of rain, if any, from a particular direction, then the risk from wind-driven is reduced and overall risk factors may be reduced accordingly (see Figure 2.9).*

*Other factors considered are relative and absolute humidity levels, and the drying potential from localised air movement.*

*Drying ability of the air outside of LEM walls is influenced by exposure to drying winds and absolute humidity and this also varies from area to area and site to site, and some allowance has been made for this. The lower the annual absolute humidity (as opposed to relative humidity) the drier the air and the greater the drying potential.*

*The risk matrix may not be appropriate to use as a definitive method of determining whether a cavity is required or not in all areas where more detailed site-specific information may be available. There is a successful in-service history internationally and in New Zealand of direct-applied plasters, to LEM buildings in some areas of the country, and successful in-service history in similar locations may be a good source of comparative performance to help with assessment.*

*Computer modelling, based on scientific research and using site-specific data is progressing as another alternative approach to help predict moisture levels within walls and the appropriate cladding systems, and to help determine whether a cavity system is required or not.*

*Any cladding system, either direct plastered or over a cavity, will require good detailing to make sure that any moisture that reaches the walls is inhibited and that the LEM remains dry (less than 20% equilibrium moisture*

content (EMC)). If the movement of moisture-laden air through the LEM is also limited then a 50-year minimum durability should be achieved (NZBC B2).

All cavity battens should be designed in accordance with SED to determine their size, type, fixings, and spacing, and to suit the cladding and its fixing in order to meet the requirements of that cladding and/or any manufacturers' installation instructions for their claddings. For fixing of claddings refer to NZBC E2/AS1.

#### **D6.7 Rain protection**

The risk factor score associated with rain wetting of exterior walls is assessed using Table D.1 and the cladding appropriate for each exposure level is given by Table D.2. The minimum eave or roof overhang of any exterior direct plastered LEM wall less than 600 mm is outside the scope of this standard.

#### **CD6.7**

There should be little problem complying with NZBC E2 if LEM is protected from external moisture by a drained and ventilated cavity beneath a suitable cladding. However, there are many instances where direct plastered LEM walls have performed very well, especially when professionally applied lime plaster is coated with an exterior silicate-based paint. Table D.2 gives guidance as to when it is appropriate to consider the use of direct plaster as an exterior cladding, as opposed to requiring a cavity system over LEM walls to give adequate weather protection.

Table D1 – External moisture risk levels for straw bale and LEM

| Risk factor                              | Score | Risk severity  | Comments   |
|--|-------|----------------|--|
| A: Wind zone                             |       |                |  |
|  | 0     | low risk       | Low wind zone as defined in NZS 3604:2011  |
|  | 1     | medium risk    | Medium wind zone as defined in NZS 3604:2011   |
|  | 2     | high risk      | High wind zone as defined in NZS 3604:2011   |
|  | 4     | very high risk | Very high wind zone as defined in NZS 3604:2011  |
| B: Roof overhang or eaves width (Note 2) |       |                |  |
|  | 0     | minimal risk   | 1:1 eaves height to eaves width  |
|  | 1     | low risk       | 2:1 eaves height to eaves width  |
|  | 2     | minor risk     | 3:1 eaves height to eaves width<br>(for example, 2.4 m height with 800 mm eaves)   |
|  | 3     | medium risk    | 4:1 eaves height to eaves width<br>(for example 2.4 m height with 600 mm eaves)  |
|  | 4     | high risk      | 5:1 eaves height to eaves width<br>(for example 3 m height with 600 mm eaves)  |
|  | 6     | very high risk | 6:1 eaves height to eaves width (or higher ratio)<br>(for example 3.6 m height with 600 mm eaves)  |
| C: Envelope complexity                   |       |                |  |
|  | 0     | low risk       | Simple rectangular, L, T, or boomerang shape, single cladding type   |
|  | 1     | medium risk    | Moderately complex shape and/or two cladding types<br>Note: Gable claddings above plastered walls are considered a single cladding   |
|  | 3     | high risk      | Complex shape and/or multiple cladding types   |
|  | 6     | very high risk | Complex shape with projections, or multi-level or <b>-re-entrant</b> shapes  |
| D: Decks/attached structures             |       |                |  |
|  | 0     | very low risk  | None or in compliance with <a href="#">D6.6.2</a>  |
|  | 1     | low risk       | Level entry timber slat decking at ground floor level (splash-back danger)   |
|  | 3     | medium risk    | Timber slat deck above ground level (not supported by the wall)  |
|  | 6     | high risk      | Attached structural members with bolts penetrating plasters. See note (4)  |
|  | 8     | very high risk | Balcony, impermeable deck, or structural members abutting or penetrating plasters. See note (5)  |
| E: Window sills                          |       |                |  |
|  | 0     | low risk       | Window sill either at floor level or not more than 1000 mm below eaves   |
|  | 1     | medium risk    | Window sill between 1000 mm and 1500 mm below eaves  |
|  | 2     | high risk      | Window sill between 1500 mm and 2000 mm below eaves  |
|  | 3     | very high risk | Window sill more than 2000 mm below eaves, but not at floor level  |
| F: Risk reductions                       |       |                |  |
|  | -1    | reduced risk   | Windows face mounted or window facings of recessed windows placed at the external face of plaster (not to be used for risk reduction if window sills at floor level). See note (7) |
|  | -1    | reduced risk   | Drying time, wall faces north quadrant (that is facing between 45 degrees east of north and 45 degrees west of north)  |
|  | -2    | low risk       | Rainfall less than 500 mm per year or wall faces dry quadrant. See note (6)  |
|  | -1    | medium risk    | Rainfall less than 600 mm per year   |

|  |    |              |   |
|--|----|--------------|---|
|  | -1 | reduced risk | Low humidity climate – annual average absolute humidity less than 9 g/m <sup>3</sup> . See note (8) |
| <p>NOTE –</p> <p>(1) If <b>roof overhangs or eaves</b> are less than 600 mm, cladding should be over a drained cavity. See D6.7.</p> <p>(2) Eaves width is measured horizontally from the external face of wall cladding to the outer edge of overhang, including fascias but excluding any external gutters or spoutings as per Figure 2.4.</p> <p>(3) Wall height here is taken as being equal to the eaves height for a wall, including a raking wall or gable end, taken as the highest point of the bottom of the barge board above the top of the wall foundation.</p> <p>(4) For example, where a stringer over the plaster has bolts penetrating the exterior plaster.</p> <p>(5) For example, a deck or other exterior feature that has walls continuous with or butting hard up against exterior LEM walls, or where structural elements penetrate plaster systems.</p> <p>(6) A wall receiving the risk reduction of low rainfall will face at least 45° away from a direction that less than 5% of the annual rainfall comes from.</p> <p>(7) Windows can be set back in a wall with timber reveals and still be finished with facings and flashed as if face mounted.</p> <p>(8) Annual absolute humidity reflects the relative drying ability of the atmosphere. To calculate this for any particular site you need annual averages for relative humidity, temperature, and atmospheric pressure, and use an online calculator to convert these into absolute humidity.</p> <p>(9) If eaves height to eaves width is greater than 6:1 then this is outside the scope of this appendix.</p> |    |              |   |

**C Table D.1**

*The risk matrix sets out the risk levels relating to the location and design features of the building.*

*Table D.1 sets out the risk matrix that should be used to define the risk score for a building within the scope of this appendix. Cladding types or systems are then selected from Table D.2 according to the risk scores.*

*The definition of eaves width and eaves height is given in 2.7.1.*

*Eaves over a ventilated drained cavity (D6.7) should be suitable for the cladding type in accordance with E2/AS1.*

*An absolute humidity calculator is available at [planetcalc.com/2167](http://planetcalc.com/2167)*

*Table D.1 deals only with the placement of windows as it affects the risk of external moisture penetration. There are other factors that are important to NZBC compliance and that influence window placement, such as thermal performance, weathertightness of the window, condensation, and thermal bridging. Windows recessed into the wall rather than face mounted perform better thermally but require deeper flashings, which increase the moisture penetration risk, and also require careful detailing at heads, sills, and jambs to ensure that they will drain moisture to the exterior of the surface of the exterior plaster. Decreasing window size is another option for improving thermal performance as walls insulate many times better than the best windows. Designers need to carefully consider and balance these factors.*

**D6.8 Wall cladding types**

The suitable wall cladding should be determined from Table D.2 for each wall using the total of the scores for risk factors A to E, which is reduced by the risk reduction factor F score, from Table D.1. A separate cladding may be selected for each wall, or the highest risk score may be used for all walls. If walls are assessed individually refer to 2.7.3 for methodology for dealing with rain from different directions.

**Table D.2 – Suitable wall claddings**

| Risk score | Suitable exterior cladding   |
|------------|--|
| 0–6.       | Lime plaster directly applied to LEM   |
| 7–12.      | Cladding over 20 mm minimum drained ventilated cavity, over 10 mm minimum exterior plaster to all LEM walls.<br><b>Roof overhang or eaves</b> over a ventilated drained cavity should be suitable for the cladding type in accordance with E2/AS1. |
| >12.       | Specific design beyond scope of this appendix.   |

**CD6.8**

*Exterior cladding including wood, metal, stucco plaster or other cladding over a cavity should be spaced a minimum of 20 mm from the LEM's encapsulating plaster to allow for moisture diffusion.*

*The cladding should be fastened to battens that should be securely fastened to the wall or structural framing at a maximum spacing suitable for the cladding all subject to SED. See D6.6.5 and CD6.9.1.*

**D6.9 Cladding details****D6.9.1 Water-resistive, sheet materials, and membranes.**

Plastered LEM walls should not be constructed with any building underlay or membrane barrier between LEM and plaster, apart from minor areas such as window flashings or where a slip or separating layer between timber members or other surfaces and plaster layers may be required.

Sheet bracing or panels may be used abutting interior LEM surfaces if the LEM is tightly fitted against vapour permeable sheet material or wall panel with a permeance greater than 290 SI units.

**CD6.9.1**

*Building underlay should not be placed between cavity battens and plastered LEM but should be placed outside cavity battens immediately behind the cladding.*

*These provisions are to facilitate transpiration of moisture from the LEM surfaces, and to prevent any membrane trapping moisture in the walls, and to secure a structural bond between LEM and plaster.*

*Using permanent boxing such as sheet bracing or linings may slow down drying of newly placed materials, even if left on only one side of a wall and should be only used with caution. They may also act as a membrane and interfere with moisture control unless carefully selected.*

**D6.9.2 Separation of LEM and steel**

Structural steel members should be separated from LEM by a timber or rigid insulation member at least 20 mm thick.

Metal strap cross bracing or other steel members adjacent to any exterior plaster coats should be wrapped with hessian before plastering.

**D6.9.3 Splash zones in interior wet areas**

LEM walls enclosing showers or in other splash zones should be protected by a cavity or timber-framed wall that is waterproofed and provided with splashbacks or lined in accordance with clause E3 of the NZBC.

**D6.9.4 Penetrations in exterior LEM walls**

All penetrations should be sealed against air and moisture infiltration on both sides of the wall.

Any exposed LEM that is otherwise hidden from view such as in ceiling spaces or behind electrical flush boxes should be plaster encapsulated.

**CD6.9.4**

*Penetrations in exterior LEM walls, excluding doors and windows, should not be in the lower half of the wall if it is possible to place them higher up to give better weather protection from roof overhangs.*

**D6.9.5 Flashings to windows, doors, and other exterior penetrations**

Flashings to all exterior openings should be designed and installed so that any water that might reach them is intercepted and directed to the exterior of the plaster system.

Head flashings should be installed at all openings.

Windowsills should have a full-width sill flashing that should be of corrosion-resistant metal or plastic (uPVC) that should have rear and side upstands and installed so that any water is directed beyond the outer face of plaster or cladding below.

If there is a window sub-sill above the sill flashing (for example of tile, brick, or timber), the sub-sill should form a drip 40 mm minimum clear of the finished exterior plaster face and the flashing should direct water beyond the exterior face of the plaster. If there is no sub-sill covering the outer edge of the sill flashing, then the sill flashing itself should extend to drip a minimum 40 mm clear of the exterior plaster face.

Where the windowsill or sub-sill is not mortared to the sill flashing, a minimum gap above the flashing of 6 mm should be provided to prevent capillary wicking of water (refer to NZBC E2/AS1 Figure 127 for sill flashing junctions with side upstands).

Jamb flashings should be of durable metal or plastic (uPVC). They should be dressed down into and onto the sill flashing, over the upstands.

Rough frames for door and window should be fastened securely to structural members.

Windows and doors in a cavity system should be installed and flashed in accordance with NZBC E2/AS1.

#### **CD6.9.5**

*Detailing of flashings around penetrations and of the junctions between joinery and direct plastered LEM is one of the most difficult aspects of LEM design and care needs to be taken.*

*Joinery that is flush mounted with flanges extending over the exterior plaster on the exterior face of LEM walls is easier to design and build than recessed joinery with the associated recessed head jamb and sill detailing and associated flashings. However, recessed joinery gives better insulation around joinery perimeter. See also CD6.4.*

### **D7 Plaster**

#### **D7.1 General**

##### **D7.1.1 Protection and permeability**

The exterior face of LEM walls should be protected by a weather-resistant cladding in accordance with this section and NZS 4298 section 8.

LEM walls should be fully encapsulated with water vapour permeable plaster on all surfaces unless abutting other vapour permeable structural elements.

An internal truth window that shows the unplastered wall material behind sealed glass is permitted.

Any paint or finish on the plaster shall be vapour permeable.

##### **CD7.1.1**

*If air can migrate readily in and out of LEM it can carry moist air into the LEM. It is important that all LEM surfaces are encapsulated with either a moisture vapour permeable plaster system or by moisture vapour permeable timber or other structural members. Non-permeable walls in front of LEM walls should be kept to a minimum and only occur on the interior side. (For example, shower walls or splashbacks in other rooms, in accordance with D6.9.3.)*

##### **D7.1.2 Voids and gaps**

All voids in LEM walls should be tightly filled with LEM mix tamped or packed in before plastering.

##### **D7.1.3 Trimming**

All LEM walls should be trimmed to a tidy surface and be very well keyed before plastering.

##### **D7.1.4 Plaster thickness**

External plaster not protected by a cavity system and other cladding, should be between 25 mm and 30 mm in thickness (all coats combined), and should be applied in not less than three coats. Plaster should be applied so that no crack penetrates all 3 layers.

Internal exposed walls should have a plaster thickness between of 20 mm and 30 mm (all coats combined).

All LEM wall surfaces otherwise open to the air either internally or externally, including tops of walls, should receive a coat of plaster no less than 10 mm thick, or greater where required elsewhere in this appendix, to fully encapsulate the LEM.

LEM wall surfaces should receive a coat of plaster no less than 10 mm thick anywhere LEM would otherwise touch metal or other non-permeable surface.

**CD7.14**

*Internal and external plaster may vary in thickness up to 50 mm to fill irregularities in the substrate.*

*Non-permeable surfaces applies to minor elements such as flashings, timber connectors, or strap bracing elements. For posts and larger see D6.9.2.*

**D7.2 Earth plaster**

Earth plaster for interior walls or behind cavities should comply with this appendix and with NZS 4298 clause 8.7 where applicable.

**CD7.2**

*Earth plasters applied to exterior LEM walls, either as straightening coats, base coats, or finishing coats are outside the scope of this standard and are subject to specialist appraisal and design as an alternative solution to the NZBC. LEM walls that are very sheltered – for example, either in a very sheltered site or deep under a very large verandah, may be successfully finished with earth plasters on external walls, either with or without additional lime plaster or whitewash, but assessment of suitability relies on experienced knowledge of the particular materials used and careful assessment of weather exposure of the wall. Its use is outside the scope of this appendix and subject to expert appraisal and specific design as an alternative solution to the NZBC.*

**D7.3 Lime plaster**

Lime plaster, fibres, and mesh should comply with this appendix and to NZS 4298 clause 8.10 where applicable.

Lime plaster may be applied internally or externally.

**CD7.3**

*Lime plaster applied over earth plaster is outside the scope of this standard. Although it has been successfully done, it is particularly dependent of a good mechanical key between the two materials and good knowledge of local materials. Its use is subject to specialist appraisal and design as an alternative solution to the NZBC.*

*Lime plaster over LEM requires very good roughening to key the surface and to pull straw or other fibres out of the surface so that they can bind in with the first plaster coat, and a thin coat of limewash should be applied first.*

**D7.4 Lime-cement plaster**

Lime-cement based plaster and mesh should comply with this appendix and to NZS 4298 clause 8.10.3. Also NZS 4298 clauses 8.10.2.3 and C8.10.3.

**D7.5 Cement plaster**

Cement plaster with less than one part lime to five parts cement should not be applied directly to any LEM walls (NZS 4298 clause C8.10.3).

**CD7.5**

*Cement plasters may be used as a cladding over a ventilated drained cavity as per NZS 4251.*

**D7.6 Gypsum plaster**

Gypsum plaster should comply with this appendix and to NZS 4298 clause 8.9 where applicable, and **be used** on internal walls only, or used as a finishing coat over other internal plaster that complies with this appendix and NZS 4298 section 8.

**D7.7 Plastering – detailed requirements****D7.7.1 Plaster reinforcement**

Any fibre or mesh used as plaster reinforcement should be in accordance with NZS 4298 clauses 8.10.4 to 8.10.11 with well keyed LEM substrates substituted for earth substrates and/or as modified here.

Plaster systems may include mesh or reinforcing fibres to control cracking and micro-cracking as required by NZS 4298 clause 8.10.4.

Reinforcing fibres may include chopped straw, hemp, sisal, jute, hair, or polyester fibres.

**CD7.7.1**

*Well-compacted LEM wall surfaces function as lath, and no other lath or mesh may be required apart from reinforcing fibres, except as required for in-plane or out-of-plane resistance as required by SED, or to prevent cracking at differences in substrate, or at corners to walls or at corners of openings, or to ensure no cracking in thin plasters behind cavities.*

**D7.7.2 Mesh types and reinforcing fibres.**

Mesh can include polypropylene, galvanised steel wire, fibreglass, or a range of fibres. Refer to NZS 4298 section 8 for mesh types and fixings.

**D7.7.3 Mesh to joints between LEM with other materials**

Where LEM abuts other materials, mesh and a slip layer complying with this section should be used to bridge the joints and to prevent cracking with all types of plaster. See NZS 4298 clause 8.10.5.

Mesh should be fully embedded in the first coat of plaster during plaster application and should extend a minimum of 200 mm onto the face of the LEM.

**CD7.7.3**

*Examples of such abutments where mesh should be used include: between LEM and timber, LEM and metal, and LEM and sheet material which is first covered by a slip layer of building underlay.*

*Mesh should be embedded in the first coat of plaster during plaster application and should extend a minimum of 200 mm onto the face of the LEM.*

*Mesh may be attached to the face of LEM substrates with stainless steel wire U-pins or staples if necessary.*

*For edge fixings see NZ4298 8.10.10.2.*

*When plastering over the joint between LEM and timber, LEM and metal, or LEM and sheet material, the non-LEM substrate should be first covered by a slip layer of vapour permeable building underlay. The building underlay should not extend over the LEM. The slip layer is to prevent hang up and the mesh is to prevent cracking at change of substrate with all types of plaster.*

*If plaster is well keyed into LEM and mesh is well embedded in plaster then u-pins may not be required in the body of the LEM wall. Any mesh attached to timber substrate requires spacers.*

*See NZS 4298 section 8.*

**D7.7.4 Plaster finishes and maintenance**

For plaster finishes and maintenance see NZS 4298 Section 8.

**D8 Roofs**

Roofs are to be designed in accordance with NZS 3604 if applicable or to SED.

**CD8**

*Many designers prefer to devise a methodology of building that puts a finished roof on the building before the LEM is put in place to give additional weather protection to unplastered LEM.*

*Roof design should be carefully considered so that any future failure that may lead to moisture getting into LEM walls is avoided or mitigated.*

*Gutters and downpipes are required on all LEM buildings and should be fitted before LEM installation if the roof is in place. Where the roof is installed after the LEM installation, the LEM requires temporary weather protection to ensure that it remains dry, and gutters and downpipes should be installed immediately after the roof is installed.*

**D9 Pipework and LEM walls**

Plumbing and drainage pipes should only be run directly through LEM walls in a sleeve that drains to the exterior and not otherwise be placed within them.

Plumbing and drainage pipes on the face of LEM walls should be separated from the plaster.



**CD9**

*Pipework within LEM walls should be minimised as there is the risk of leaking but also water pipes can be cool and act as points of moisture condensation within the walls.*

*Exterior pipework through a LEM wall requires careful detailing that should include pipe insulation and a sleeve with a downward slope to the exterior face of the wall.*

**D10 Electrical services in LEM walls**

Electrical wires should be run more than 40 mm from the face of LEM walls. Any penetrations through plaster skins need to be well sealed, and items such as flush boxes should be plastered behind to limit air infiltration.

All cable, conduit systems, flush, and junction boxes should be securely attached to wall framing. Additional framing members should be installed as necessary.

**CD10**

*It is recommended that all electrical wires be run within conduits within LEM walls or otherwise behind skirtings and scotias to allow for future maintenance.*

**D11 Thermal insulation****D11.1 k and R-value**

LEM, with a density of 200 kg/m<sup>3</sup> when installed according to this appendix, has a *k* value of 0.1 W/m°C and LEM with a density of 800 kg/m<sup>3</sup> has a *k* value of 0.25 W/m°C.

*R*-value = 1/*k* × thickness in metres.

The value for intermediate densities may be interpolated in accordance with values derived from the graph in Figure 2.10.

The *k* value for earth and lime plasters may be taken as 0.7 W/m°C with an *R* value of 0.02 when 10 mm thick and 0.06 when 30 mm thick.

The *k* value for cement/lime plaster may be taken as 0.8 W/m°C with an *R* value of 0.01 when 10 mm thick and 0.03 when 30 mm thick.

*R* (Surface effects) = *R* 0.9 (internal) °C.m<sup>2</sup>/W + *R* 0.3 (external) °C.m<sup>2</sup>/W and may be taken as together as equalling *R* 0.12 °C.m<sup>2</sup>/W.

**CD11.1**

*A 300 mm LEM wall with a density of 200 kg/m<sup>3</sup> and 30 mm lime exterior and 30 mm earth plaster interior thickness would have a R-value of:*

$$0.3 \times 1 \div 0.10 = 3.0 \text{ } ^\circ\text{C.m}^2/\text{W}(\text{LEM}) + R \text{ 0.12 (plaster)} + R \text{ 0.12 (surface effects)} = 3.24 \text{ } ^\circ\text{C.m}^2/\text{W}.$$

*A 300 mm LEM wall with a density of 500 kg/m<sup>3</sup> would have a R value of:*

$$0.3 \times 1 \div 0.15 = 2.0 \text{ (LEM)} + R \text{ 0.12 (plaster)} + R \text{ 0.12 (surface effects)} = 2.24 \text{ } ^\circ\text{C.m}^2/\text{W}.$$

*A 300 mm LEM wall with a density of 800 kg/m<sup>3</sup> would have a R value of:*

$$0.3 \times 1 \div 0.25 = 1.2 \text{ (LEM)} + R \text{ 0.12 (plaster)} + R \text{ 0.12 (surface effects)} = 1.44 \text{ } ^\circ\text{C.m}^2/\text{W}.$$

*A 300 mm thick wall with a density of 1200 kg/m<sup>3</sup> would have a R value of:*

$$0.3 \times 1 \div 0.45 = 0.67 \text{ (LEM)} + R \text{ 0.12 (plaster)} + R \text{ 0.12 (surface effects)} = 0.9 \text{ } ^\circ\text{C.m}^2/\text{W}.$$

*For walls 200 mm thick multiply the R-values for the LEM by 0.66, and for a 150 mm thick wall multiply the R-values for the LEM by 0.5. The R(plaster) and R(surface effects) will remain the same.*

*Thermal modelling is required to show thermal mass benefits of LEM in demonstrating compliance with NZBC H1.*

**D12 Fire****D12.1 LEM walls are not fire rated.****CD12.1 Fire risk during construction**

*LEM walls are not particularly vulnerable to fire before they are plastered. Although loose straw or other fibres are a fire hazard during construction, once clay coated they are relatively fire resistant.*

*Risk can be reduced by measures that include:*

- (a) Cleaning up any loose straw or other flammable fibres and removing them from the building site;*
- (b) No smoking on site;*
- (c) Provision of fire extinguishers on site.*
- (d) Recommending only electric-powered line grass trimmers be used within 10 m of bales or loose straw or other flammable fibres as there is a fire risk from the use of petrol motored trimmers or chainsaws;*
- (e) Not allowing angle grinders or other equipment that emits sparks to be used within 10 m of loose straw or other flammable fibre;*
- (f) Site fencing to exclude all unauthorised persons;*
- (g) Provision of fire extinguishers on site.*

**D12.2 Clearance to fireplaces and chimneys**

LEM surfaces adjacent to fireplaces or chimneys should be finished with a minimum 25 mm thick reinforced plaster of any type permitted by this appendix and should have no cracks.

Clearance from the face of such plaster to fireplaces and chimneys should be maintained as required from fireplaces and chimneys to combustibles in AS/NZS 2918 or as required by manufacturer's installation instructions, whichever is more restrictive.

**CD12.2**

*Installation of horizontal flues from solid fuel heaters or boilers installed passing through an external LEM wall are outside the scope of this standard. See also CE8.*

**D13 Diagrams****CD13**

*All of the following diagrams are indicative only to show general principles as an aid to designers.*

*Details that show window joinery in direct plastered and cavity walls are also indicative only and specific details that comply with NZBC E2 are the responsibility of the designer.*

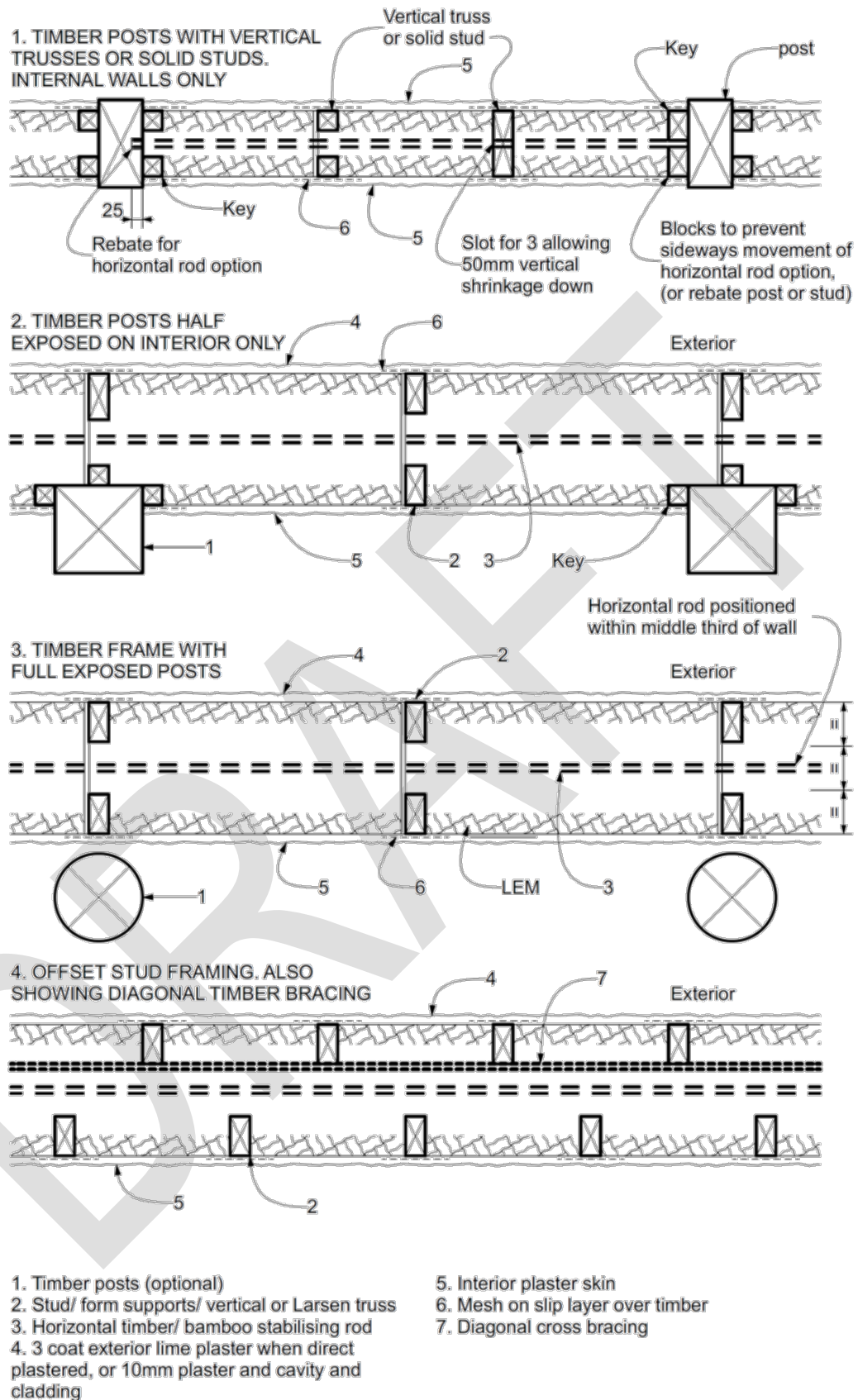
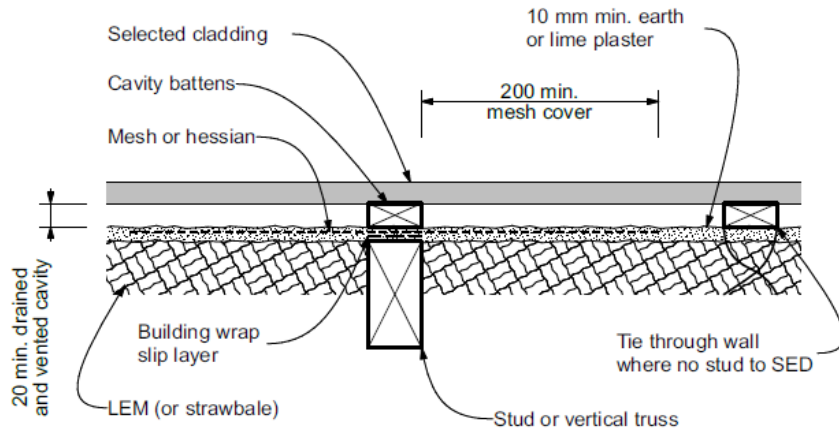

Figure D.1 – Some diagrammatic only framing options for LEM



NOTE-  
If the exterior plaster is fully meshed it can act as a rigid air barrier.

Figure D.2 – Drained vented cavity to LEM

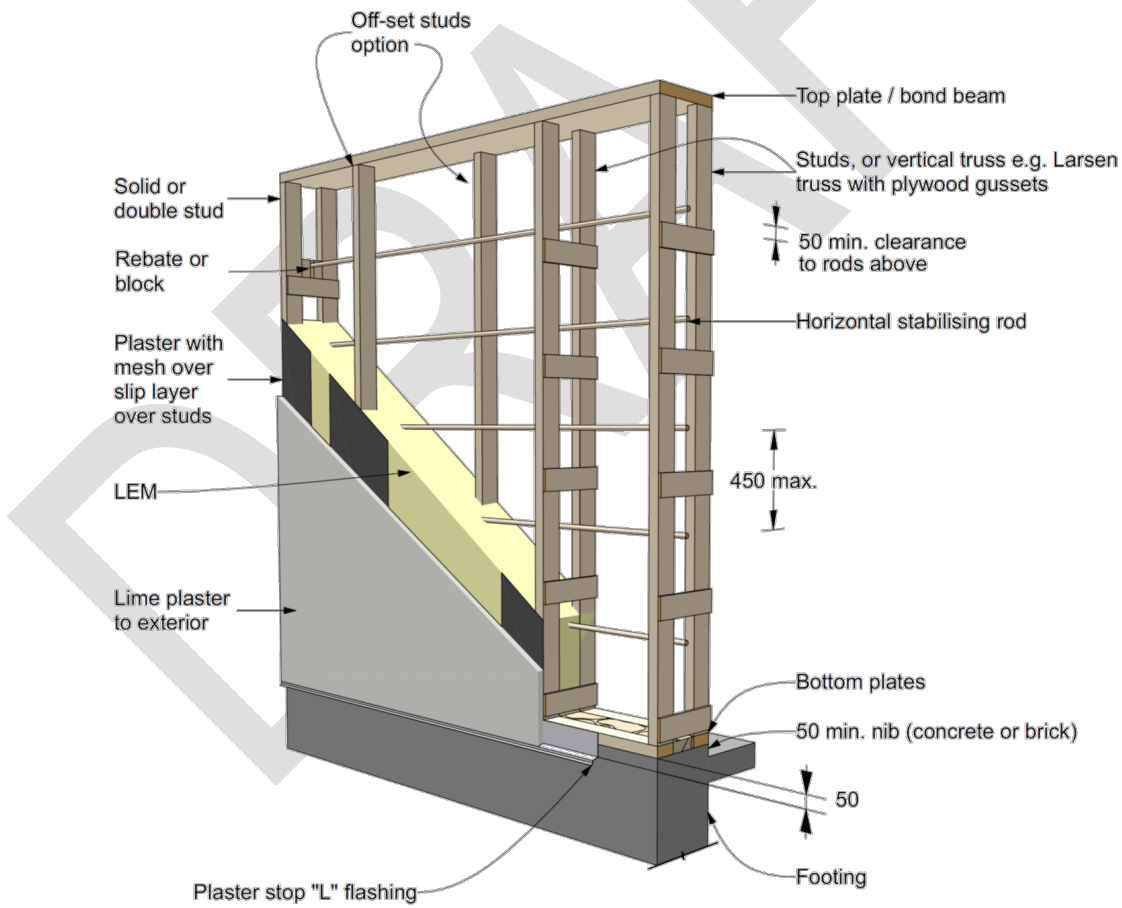

Figure D.3 – Typical LEM wall – diagram only showing some elements and options

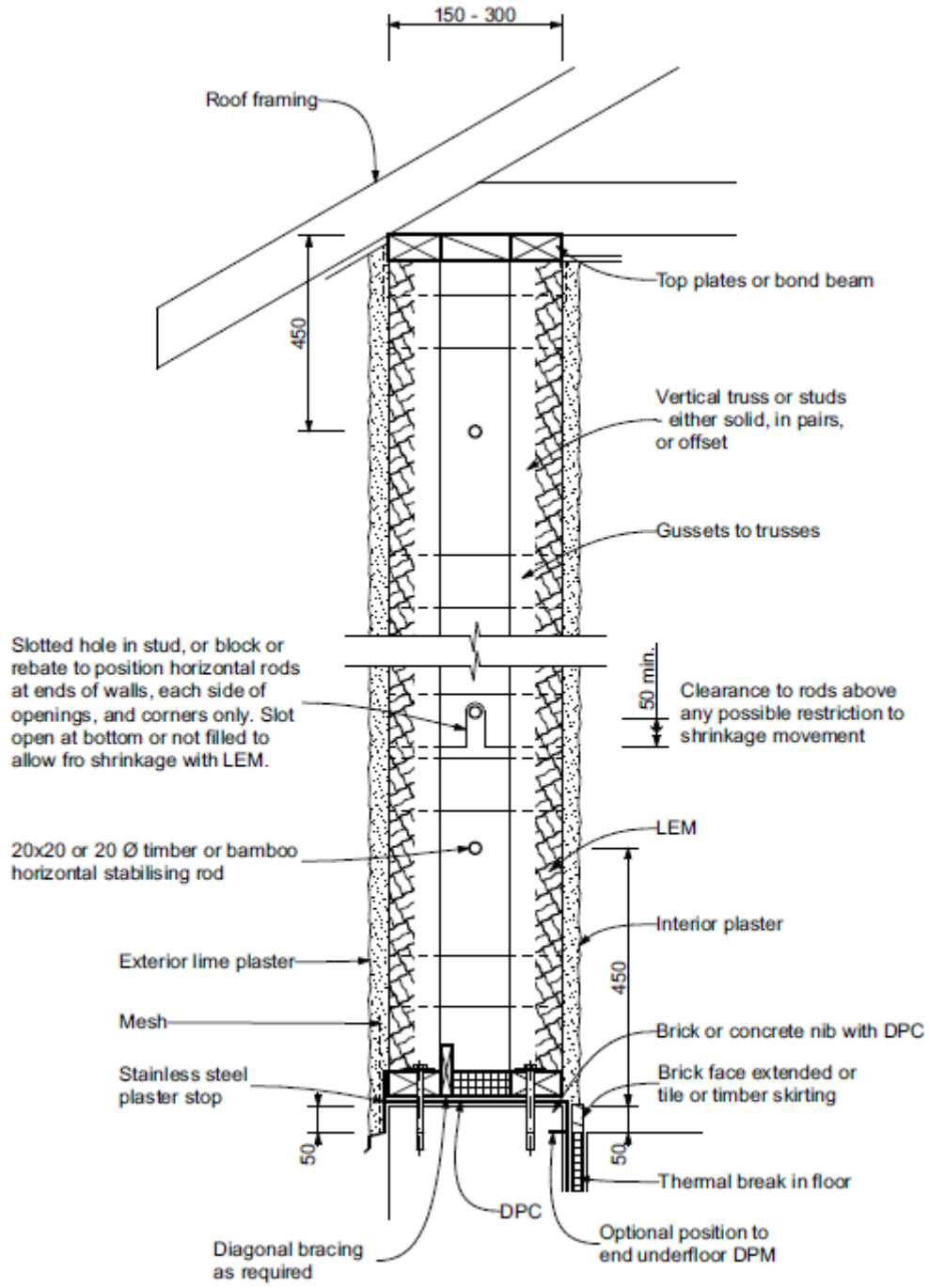

Figure D.4 – LEM wall section

## APPENDIX E – STRAW-BALE CONSTRUCTION

(Informative)

### E1 General

This appendix provides both prescriptive and performance-based requirements for the use of baled straw as a building material within a structural timber framework. It may act as a guide for practitioners and building officials when assessing the use of straw bales as alternative solutions to demonstrate compliance with the NZBC. This appendix is complementary to Appendix D Light Earth Method or LEM, which contains material also relevant to straw-bale design and construction.

The diagrams that are included with this appendix are indicative only to show general principles as an aid to designers. Details that show window joinery in direct plastered and cavity walls are also indicative only and specific details that comply with NZBC E2 are the responsibility of the designer.

#### CE1

*Straw-bale construction is relatively new to New Zealand but is proving to be a viable and resource efficient method of construction.*

*First practised in Nebraska in the late 1800s and with buildings over 120 years old still in service, straw-bale construction was rediscovered in the 1980s in the American Southwest and introduced to New Zealand in the 1990s. Since then it has been further developed and explored, with considerable testing and research undertaken regarding structural performance (under vertical and lateral loads), moisture, fire, and its thermal and acoustic properties.*

*Straw bales have been shown to perform very well under earthquake loads in New Zealand and around the world. The bales can absorb seismic energy, and also will still carry load without collapse even when loaded past their yield point.*

*The use of straw bale in buildings has been hampered in New Zealand by a lack of relevant straw-bale building guidelines or standards.*

*There are several ways in which straw-bale walls may be successfully designed and built, and some are described here.*

*This appendix deals with non-loadbearing straw bales set within a timber frame that carries all structural loads.*

*The timber frames may be a series of vertical studs and top plates or beams made from light timber framing, or timber with plywood flanges, or a heavier timber post and beam system.*

*Loadbearing straw-bale walls, that is, walls where the straw bales directly support roof and/or floor loads, have been built successfully in New Zealand as well as overseas, but they are beyond the scope of this appendix. Using straw-bale panels as bracing panels that resist in-plane loads is possible but is outside the scope of this appendix and is subject to SED.*

*Non-loadbearing straw-bale walls need to resist out-of-plane face loads – these are essentially wind, impact, or seismic loads – as well as needing to provide support for the plaster coatings and any additional cladding if they are external walls.*

*Internal walls also have to be designed for seismic loads and therefore are no different in the strength requirements with respect to external walls.*

*Straw-bale walls may be thought of as bale walls that are later plastered, but in reality they form composite panels comprising a straw-bale core between plaster skins, where the plaster skins are intrinsically connected to and supported at all points by the straw-bale core. For the composite panels to perform well, the core of bales needs to be tightly fitted between foundation and roof, and between vertical structural members, and with the straw-bale panels well connected to a structural timber frame.*

*The surface coatings in 4298 section 8 have not been assigned any structural properties. Reinforced plaster skins may be feasible but will be subject to SED. Attributing bracing strength is outside scope but has been done by some practitioners.*

*For a summary of many structural tests and parameters for the design of plastered straw-bale walls, engineers and designers are referred to Chapter 4, 'Structure', Design of Straw bale Buildings,' Bruce King et al.*

*This appendix draws upon local and international experience and also from 'Appendix S, Straw bale Construction' to the '2015 International Residential Code' (USA).*

## E2 Scope

### E2.1 Scope inclusions

This appendix covers building with straw bales that are either laid on the flat, or on edge, or on end, to form non-loadbearing walls set within a timber structural frame that is subject to SED.

The scope of coverage includes:

- (a) Earthquake zones 1, 2, and 3 as defined in 4.2;
- (b) Maximum wall height of 2.7 m for pre-compressed straw-bale walls with plaster not containing mesh and without intermediate support;
- (c) Maximum wall height 3.6 m for straw-bale walls with plaster containing mesh that complies with NZS 4298 section 8;
- (d) A maximum straw-bale wall slenderness ratio of 1:8 without intermediate support;
- (e) Wall width 300 mm to 500 mm excluding plaster coats, cavities, or cladding;
- (f) Single storey;
- (g) Wind zones low (L) to very high (VH) to NZS 3604.

#### C E2.1 (f)

*This appendix does not preclude designs that incorporate other methods of straw-bale building, or buildings of two or possibly even more storeys, especially if the cladding includes a cavity, or otherwise protects the straw from all adverse affects of external moisture in particular, affects that generally increase with building height. Such designs are outside the scope of this standard.*

### E2.2 Scope exclusions

The following are not within the scope of this appendix:

- (a) Panelised or prefabricated wall systems;
- (b) Structural design of straw-bale walls, including bracing;
- (c) Loadbearing straw-bale walls;
- (d) Straw used below finished ground level, in subfloor areas, or in exterior parapet walls;
- (e) Exterior walls that are not vertical, that is more than  $\pm 20$  mm/m from vertical.

## E3 Definitions

Additional to this appendix:

The following words and terms should, for the purposes of this appendix, have the following meanings.

|                              |   |
|------------------------------|---|
| <b>Bale</b>                  | Equivalent to straw bale  |
| <b>Bale staples or U-pin</b> | A U-shaped metal reinforcing bar embedded at the junction of straw-bale walls to secure abutting bales to each other at every course  |
| <b>Clay slip or slurry</b>   | A suspension of creamy consistency of clay particles in water   |
| <b>Climate zone</b>          | The climate zones defined in <a href="#">NZBC H1/AS1</a> .  |
| <b>Flake</b>                 | An intact section of compressed straw removed from an untied bale   |
| <b>Laid on edge</b>          | The orientation of a bale with its largest faces vertical, its longest dimension parallel with the wall plane, its strings on the face of the wall, and its straw lengths predominantly oriented vertically |
| <b>Laid on end</b>           | The orientation of a bale with its longest dimension vertical. For use in non-structural straw-bale walls only  |

|                           |  |
|---------------------------|--|
| <b>Laid on flat</b>       | The orientation of a bale with its largest faces horizontal, its longest dimension parallel with the wall plane, its strings concealed in the unfinished wall, and its straw lengths predominantly oriented across the thickness of the wall |
| <b>Lime water</b>         | Water taken from the top of a storage container of lime putty  |
| <b>Mesh</b>               | An openwork fabric of linked strands of metal, plastic, synthetic fibre, or natural fibre used to reinforce plaster  |
| <b>Mesh U-pin</b>         | A 'U' shaped galvanised hi-tensile wire pin with 130 mm minimum legs to hold mesh to the bales prior to plastering with 130 mm minimum legs  |
| <b>Pin</b>                | A vertical metal rod, wood dowel, or bamboo, driven into the centre of stacked bales, or placed on opposite surfaces of stacked bales and through-tied   |
| <b>Pre-compression</b>    | Vertical compression of stacked bales before the application of finish   |
| <b>Reinforced plaster</b> | A plaster containing continuous mesh reinforcement over an entire wall section   |
| <b>Running bond</b>       | The placement of straw bales such that the head joints in successive courses are offset at least one-quarter the bale length   |
| <b>Skin</b>               | The compilation of plaster or reinforced plaster applied to the surface of stacked bales. Also SURFACE COATING in 4298 section 8   |
| <b>Stack bond</b>         | The placement of straw bales such that head joints in successive courses are vertically aligned  |
| <b>Strapping</b>          | 700 kg breaking strength woven polyester or polypropylene strapping or 2.0 mm diameter high-tensile wires  |
| <b>Straw</b>              | The dry stems of cereal grains after the seeds and/or seed heads have been substantially removed of wheat, rice, rye, barley, or oats  |
| <b>Straw bale</b>         | A rectangular compressed block of straw, bound by at least two ties  |
| <b>Straw-bale</b>         | The adjective form of straw bale   |
| <b>Structural wall</b>    | A loadbearing wall or shear wall   |
| <b>Tie</b>                | A synthetic fibre, natural fibre, or metal wire used to confine a straw bale   |
| <b>Truth window</b>       | An internal area of a straw-bale wall left without its plaster finish, with a transparent or solid cover to allow viewing of the straw otherwise concealed by its finish   |
| <b>Vapour permeable</b>   | Measure of a materials ability to transmit water vapour through it. Sometimes referred to as breathability. See PERM, PERMEANCE, PERMEABILITY PERMEABLE in definitions NZS 4298  |



## E4 Materials

### E4.1 Straw bales

Bales should be a rectangular prism in shape, and made from the stems of wheat, rice, rye, barley, linseed, or oats.

Bales of pea straw, hay, and other grasses, or containing leaf matter and/or seed, or bales showing signs of previous wetting, mould, or water damage should not be used.

### E4.2 Size

Bales should have a minimum height and thickness of 300 mm except as otherwise required or allowed in this appendix. When laid on the flat or on edge the bale length should not exceed 3.5 times the bale height. Bales used within a continuous wall should be of consistent height, thickness, and density to ensure even distribution of loads within the wall system.

#### CE4.2

*Common bale dimensions are nominally 350 mm × 450 mm × 900 mm to 1000 mm long.*

*Loose, bent, or over-long bales for a particular location may be modified to specific length by retying to the same or greater density of regular bales.*

### E4.3 Ties

Bales should be confined with a minimum of two ties.

Ties should be polypropylene or sisal baling twine with a minimum tensile strength of 64 kg knot strength, or galvanised tie wire. Ties should be positioned in such a manner as to maintain bale shape and density during transport and wall construction.

Bales with broken ties should be retied to maintain original bale shape and meet the required bale density.

#### CE4.3

*The ties are the material supplied for mechanical hay or straw baling. Galvanised wire ties may also be used. Bales may also be retied using full 19 mm polyester textile strapping with a minimum breaking strength of 4 kN and secured with a metal clamp or buckle with a minimum strength of 4 kN.*

### E4.4 Moisture

Straw bales are to be kept dry at all times, that is, with a moisture content less than 20%. Refer to E6.4.

#### CE4.4

*Bales need to be protected from moisture at all times, from the time of baling, during storage and transportation, throughout the building process until plastered. This includes ground moisture either from direct contact or from proximity by being close to wet ground. Bales are generally stored on pallets. If the bales are stored in areas close to vehicle movements ensure that they're protected from splashing. Ensure that any covering of bales does not inadvertently trap moisture.*

### E4.5 Density

Bales should have a minimum dry density of 90 kg/m<sup>3</sup>.

The dry density may be calculated by subtracting the weight in kilograms of moisture in the bale (as determined by CE6.4) from the actual bale weight and dividing by the volume of the bale in cubic metres.

Not less than 2% and not less than five bales to be used should be randomly selected and tested on site for density.

#### CE4.5

*Density tests may be done by the owner or the owner's representative, or by an accredited laboratory. Record the results and provide copies to the territorial authority on request.*

### E4.6 Low-density or partial bales

Low-density bales (that is with a dry density less than 90 kg/m<sup>3</sup>) may be compressed and retied to obtain the required bale density.

**CE4.6**

*If bales are cut and retied then the minimum density and integrity of the requirements of this appendix should be obtained.*

**E5 Wall construction****E5.1 General**

This section is included to assist designers.

In all methods, the end result is tightly packed bales within a wall panel prior to plastering that will not be able to be withdrawn from the wall by hand pressure alone, nor readily knocked out of place with a sledgehammer.

**CE5.1**

*To achieve tightly packed straw-bale walls, the walls need to be designed to allow some vertical compression of bales within the frame as the bales are placed and securely fixed to adjoining structural members including top plates or beams, and posts.*

*Framing around window and door openings may also act as vertical posts, and needs to be designed so that the bales can be fitted and secured, and joinery installed, while still allowing for fitting and movement during stacking of the bale walls to take place.*

*Construction is easier if the structural frame and bracing is designed so that it is possible to insert the straw bales without cutting bale ties and having to retie bales unnecessarily.*

*Bracing may be supplied by diagonal metal strapping, diagonal timber braces, sheet bracing for example plywood or plaster board, reinforced plaster skins, or timber poles. Straw bales are not to be placed with the walls abutting impervious surfaces, and this may include sheet bracing, apart from minor exceptions. See E7.*

*All bracing design is subject to SED.*

*The position of bracing within a wall may be constrained by the bale ties that need to be kept intact within the walls as the bales are put in place, and any diagonal bracing also needs to allow for changes in vertical dimension of the bales as the bales are stacked in, or if a whole wall is to be compressed.*

*Steel posts, steel beams, steel connectors, and steel bracing elements, under some conditions, can have moisture within the walls condense on them, and therefore it is recommended that direct contact between steel and straw bales cannot occur.*

*Diagonal metal strap bracing can be placed on the internal (warm) or external (cold) face of external straw-bale walls, although some designers have a preference for placing strap bracing on the warm side of the wall if practicable, or if on the cold side, wrapping them with plastered hessian and placing 10 mm of clay or lime plaster between the strap and the straw.*

*In adverse events, such as earthquakes the diagonal metal strap bracing can buckle and penetrate the plaster system, thus requiring repair.*

**E5.2 Bottom plates**

Timber bottom plates should be supported on a foundation designed to SED. Timber piled foundations as shown in Figures E.9 and E.10 may be utilised.

Timber bottom plates should be provided beneath straw-bale walls.

As a minimum these should be a pair of 90 mm x 45 mm spaced-apart or full-width timber and set flush with each face of the straw bales above. The outer plate may overhang the foundation by up to 50 mm while retaining a minimum of 80 mm bearing on the foundation.

A concrete or brick nib may be built up beneath the bottom plates up to a maximum height of 150 mm.

The exterior face of the bales is to be flush with the exterior face of the outer plate. The interior side of the bales is to be flush with the interior side of the inner plate.

Anchoring should be to SED.

A sheet or liquid applied DPM should be applied over the top of the concrete or masonry foundation the full width of the wall beneath the bottom plates.

The void between the bottom plates should be filled flush with timber, solid insulation, or a material that allows vapour dispersion, and should not be vented to the outside air.

**CE5.2**

*The bottom plates are provided to lift the bottom of the straw bales a minimum of 45 mm above floor level to keep any bales dry in case of water getting onto the floor during construction or in service, and to create a thermal and moisture break from any concrete foundations. They also provide fixing for mesh, and plaster stops, and for fastening of diagonal bracing.*

*Vapour dispersing infill material between the plates can include timber, or free-draining mineral fill such as coarse pumice sand or scoria, vermiculite, or pea gravel with a slightly mounded top surface.*

*Insulation is important to prevent the formation of a cold surface that condensation may form on. Polystyrene can be a suitable void former in service even though it has relatively low vapour diffusion through it.*

*No fines aggregate smaller than 19 mm may be used, as the air gaps make it less cold than solid concrete and any moisture formed can drain away from the straw/void filling interface.*

*A concrete or brick nib, usually around 50 mm high is sometimes installed beneath the bottom plates to ensure that the bottom of the straw-bale wall assembly is kept well clear of moisture either during construction or occupation.*

**E5.3 Wall details****E5.3.1 Stacking bales**

Bales should be tightly laid in a running bond with minimal gaps or voids. A wall equal to or less than one bale long of minimum length should be stack bonded.

**CE5.3.1**

*Some practitioners also pin all bales together See CE5.3.3.*

**E5.3.2 Securing the first course of bales**

The first course of bales are to be secured to the foundation against horizontal movement by a series of nails 75 mm to 100 mm long driven in near the inner edges of both bottom plates with the shank primarily proud of the surface, at 300 mm to 500 mm centres (six minimum per whole bale), one row per plate and 75 mm minimum in from the outer edge of both bottom plates, to help locate and secure the first course of bales.

**CE5.3.2**

*Nails placed towards the outside edges of bottom plates are ineffective for securing the bale in place.*

*If the straw-bale walls are meshed, or pre-compressed with straps, the mesh and/or straps may act as the connection between the bales and the bottom plates.*

**E5.3.3 Securing straw-bale wall corners or intersections**

Corners of abutting straw-bale walls or wall intersections not supported by structural framing should be secured together with baling tie material that secures the bale ties together between adjacent bales across the corner.

Vertical pins may also be driven in through bales at corners or intersections into the bale below to help secure bales in place.

**CE5.3.3**

*Although it is not necessary to pin bales, some practitioners install up to four per bale.*

*Dowels or pins generally are a minimum of 15 mm diameter or 20 mm × 20 mm timber, or D12 mm steel in [climate zones 1 to 3, as defined in NZBC H1/AS1](#) or 20 mm diameter bamboo, and long enough to penetrate through two courses of bales. Dowels may be sharpened to a point to facilitate ease of installation and to prevent damage to bales. For use of steel in climate zone 3 see E8.3.*

*Pins are sometimes employed to provide location of the bales, and stability with two to four used per bale, and long enough to penetrate through two bale courses. Steel pins should not be used anywhere within straw-bale walls in climate zone 3 (see E8.3).*

**E5.3.4 Attachment of bales to timber framing elements**

Connect bale ties to timber framing with tie material wherever possible to give stability and after any pre-compression of the whole wall has taken place prior to plastering.

Timber frame interior walls perpendicular to, or at an angle to, a straw-bale wall assembly should be well fastened to the bottom and top timber members of the straw-bale wall.

If connection to top timbers is not possible, an abutting stud should be connected to alternating straw-bale courses with a 12 mm diameter steel, or 15 mm diameter wood, or 20 mm diameter bamboo dowel, with not less than 200 mm penetration horizontally into straw bales. The first coat of plaster should be reinforced and continuous over bales behind any abutting stud.

Subsequent layers of plaster should butt up to the sides of the stud.

Temporary bracing of straw-bale walls may be required during construction.

#### **CE5.3.4**

*When plasters over straw-bale walls are meshed with wire or polypropylene mesh (see NZS 4298 section 8), the mesh reinforced plaster may act as the attachment between bales and framing elements.*

*Otherwise, bales may be pinned to vertical timber framing that supports window and door frames with two (minimum) wood dowels per timber member each side of each opening and at intermediate structural framing if any, and at the ends of walls.*

See CE5.3.3 and CE5.3.5.

*Dowels if used should be driven horizontally into the centre of whole bales, with a maximum vertical spacing of twice the bale height or 900 mm or as determined by SED.*

*Once a wall is completed and plastered the pins contribute little to the overall structure, but they can help with temporary stabilisation of the wall as it is being built prior to plastering.*

*Internationally it is becoming increasingly common for bales in walls not to be pinned or tied in as this is regarded as temporary stabilisation pre-plaster.*

#### **E5.3.5 Connection of interior timber-frame walls to straw-bale walls**

Timber frame interior walls perpendicular to, or at an angle to, a straw-bale wall assembly, should be well fastened to the bottom and top timber members of the straw-bale wall.

If connection to top timbers is not possible, an abutting stud should be connected to alternating straw-bale courses with a 12 mm diameter steel, or 15 mm diameter wood, or 20 mm diameter bamboo dowel, with not less than 200 mm penetration horizontally into straw bales. The first coat of plaster should be reinforced and continuous over bales behind any abutting stud.

Subsequent layers of plaster should butt up to the sides of the stud.

Temporary bracing of straw-bale walls may be required during construction.

#### **E5.3.6 Coating**

All straw-bale walls should be very tightly packed in accordance with E5.4 and secured in the wall in accordance with E5.3.5, and with all voids filled prior to plastering.

Plaster coatings are applied in accordance with E7.

#### **E5.4 Different techniques for building straw-bale walls prior to plastering**

##### **E5.4.1 Pre-compression of straw-bale walls using external straps**

Strapping may be either woven polyester or high-tensile fencing wire.

The straps are run continuously under the bottom plates and tensioned each side of the wall using mechanical tensioners and fasteners to the maximum that the strap tensioners will allow.

Full pre-compression typically may be up to 150 mm vertically. The more dense the bales the less compression that will be achieved in a wall.

The straps are installed under the bottom plates, taken up each side of a wall and run over the tops of a centrally placed top plate or platen of solid timber 40 mm thick, or plywood a minimum of 12 mm thick, the full width of bales less 25 mm maximum each side. Alternatively, the straps may be run through a 20 mm diameter duct cast from side to side through a nib.

The straps should be run vertically and placed at 600 mm centres maximum horizontally, and a maximum of 150 mm from the ends of bales at each end of each straw-bale wall. At corners the straps should run as close to the corner as possible on each leg of the corner.

One or more of the following strapping methods may be used:

- (a) Plastic strapping should be 19 mm woven polyester textile strapping with a minimum breaking strength of 7 kN. Strapping should be secured with a non-corroding metal clamp capable of developing a joint with a strength of at least 4 kN; or
- (b) High-tensile fencing wire with the addition of metal corner edge protectors to any timber plates, tightened with a proprietary fencing tool wire joiner and connector.

Compression strapping should be tied to the opposing strapping through the bale walls with polypropylene baling twine or galvanised tie wire at 600 mm centres vertically if the strapping is not fitting tightly against the bale walls prior to plastering, or if required by SED.

After compression this platen should be structurally fastened to the surrounding timber structure.

#### **CE5.4.1**

*E5.4.1 describes a method where the bales are stacked in the wall, and then pulled down vertically and very tightly compressed together if constructed using compression rods or straps running between a moveable platen or top plate on top of the straw bales that is pulled down against the bottom plates.*

*This gives a wall enough density to the straw and enough stiffness to allow the wall to be connected to the surrounding structure and plastered without the need for any extra mesh being strictly necessary in earth or lime plasters, nor the need to ascribe any structural strength to the plasters.*

*The bales themselves act as a lath for the plaster, and only require fibres or mesh in the plasters for the purpose of crack control. Exterior plasters, when directly applied to the wall, are also the weather-resisting cladding.*

*The stiffness of the wall is also such that cavity battens if needed can be tied to or through the body of the wall.*

*With this method there is the need to allow for a variable amount of vertical movement of the platen or top plate against any structure such as fixed posts and beams.*

*The total amount of compression achieved at any point is determined by the need to keep the top plate level and what the compression method allows and is typically around 2% to 4% of the initial height of the bales.*

*If each side of the bales is dipped in clay slip before laying, or the bales are particularly dense, then compression to the maximum that a strapping system can achieve is considered acceptable.*

*The building elements that surround the straw-bale walls need to allow bale placement and compression to occur and designers need to provide for this.*

*Plaster mesh and/or compression strapping may also contribute to out-of-plane and in-plane resistance.*

#### **E5.4.2 Pre-compression of straw-bale walls within a structural frame**

In this method, the bales are tightly fitted into a fixed opening in a structural timber frame.

The top of the opening is approximately 50 mm to 75 mm lower than the height of all the courses of stacked but uncompressed bales.

Before the top row of bales is installed, the next to last row of bales are temporarily jacked or otherwise compressed downwards beneath the fixed top plate or beam, to create a gap wide enough into which the last bales are forced.

#### **CE5.4.2**

*In this technique the next to last row of bales are temporarily compressed downwards below the fixed top plate or beam, and the gap filled with very tightly fitting straw bales. Expansion of the bales below when the compressing force is released ensures a tight fit and gives the wall its pre-compression.*

*The size of the opening has to be suited to the available bale sizes and course heights. If the opening is such that an exact fit of full bales cannot be obtained, then the top row of bales or the opening height will need to be modified. It is much easier to adjust the bale height if the bale wall is designed with the bales laid on edge so that the bale height can be trimmed without cutting bale ties.*

*Plaster reinforced with mesh transfers out-of-plane loads from the wall panel to the surrounding structure.*

**E5.4.3 Tightly packed bale walls, not otherwise pre-compressed**

Bale walls that are very tightly packed into the wall but not otherwise pre-compressed.

The bottom bales are located in place on bottom plates with nails (see E5.3.2).

As the bales are tightly placed in the walls within the structural frame, two to four pointed pins are driven through each bale and into the ones below, as bale wall building proceeds.

Galvanised wire netting is pinned onto the bales, and the netting is fixed to enclosing timber members with staples allowing for spacers (4298 section 8).

Netting is tied from face to face through the bale with galvanised tie wire, with a minimum of two ties per bale.

**CE5.4.3**

*Pins may be employed to provide location of the bales, and stability to the wall being built, with two to four used per bale and long enough to penetrate through two bale courses. See also CE5.3.3. Steel pins should not be used anywhere within straw-bale walls in climate zone 3 (see E8.3).*

*E5.4.3 describes a method of building straw-bale walls that relies on the bales being constructed very tightly in place, but not otherwise pre-compressed further within a structural timber frame. A fibrous lime plaster or a cement/lime plaster (NZS 4298 section 8) should be applied to both sides of the wall panel. Additional stiffness during building comes from pinning the bales together but is ultimately provided by using a steel mesh reinforced high-strength plaster to form a composite straw-cored plaster-skinned panel that will resist out-of-plane stresses.*

*To ensure the quality of the plaster, some practitioners apply commercially blended lime-cement plaster using a pump to give good mechanical bonding and bale/void penetration between the first plaster coat and the straw. The second plaster coat and subsequent top/sponge coat are also pump applied followed by applying a siloxane coating or mineral based paint (NZS 4298 section 8).*

**E6 External and internal moisture control for straw bale****E6.1 General**

Straw-bale walls should be protected from moisture, water intrusion, and subsequent damage at all times.

Close attention needs to be given to all plaster edges where care with the details is paramount.

**E6.2 Surface moisture**

Bales should be separated from finished ground level by not less than 320 mm to unpaved ground or 245 mm to permanent paving.

**CE6.2**

*If the bales are behind a rain-screen cavity the distance may be reduced to 225 mm and 150 mm respectively. It is noted that the dimensions are in excess of those in 5.2.3.2 for earth walls.*

*There is a risk of splash-back from rain if finished ground levels are less than these.*

**E6.3 Separation of exterior plaster and finished ground level**

Exterior plaster should be located not less than 225 mm above finished ground level or 150 mm above permanent paving or adjoining deck surfaces. See Figure E.1.

**CE6.3**

*Decks or areas well sheltered not subject to wind-driven rain may be closer to finished ground level where splash-back is not of concern, for example in sheltered areas under verandahs, or other rain-screening features.*

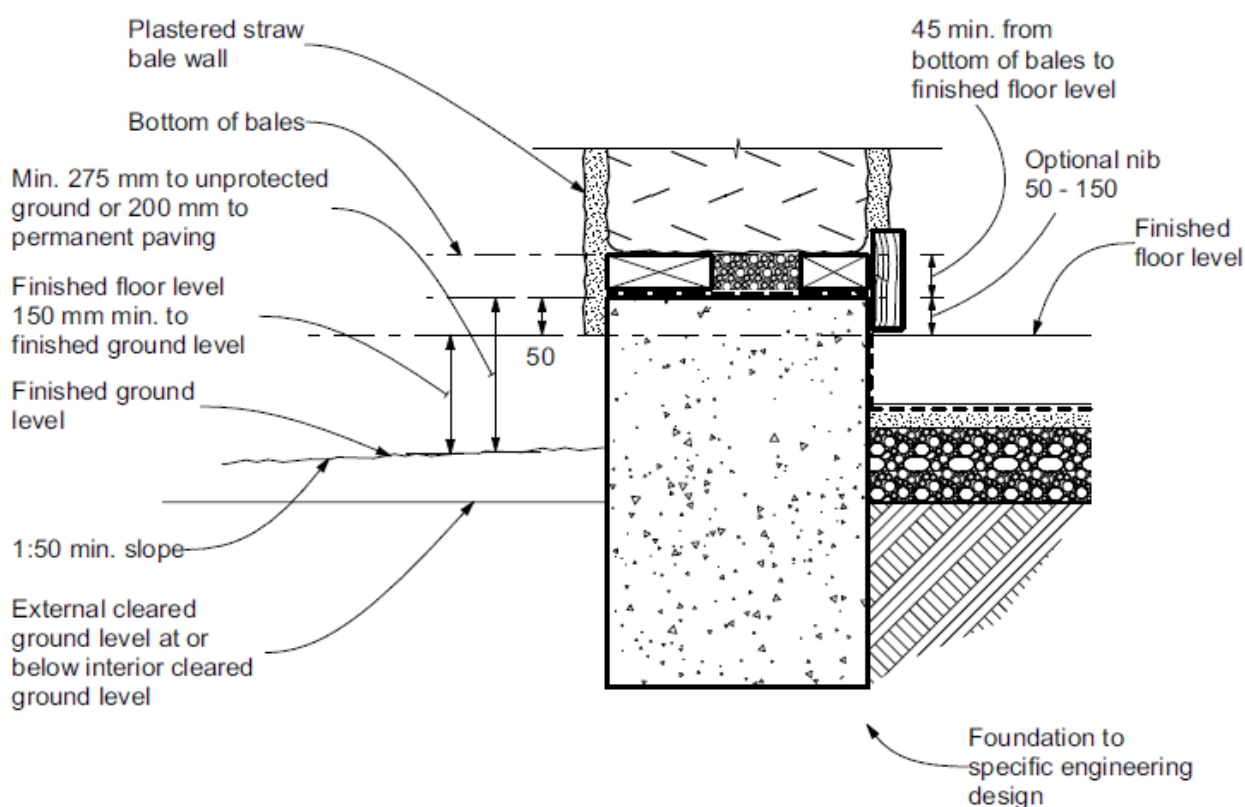

Figure E.1 – Ground clearances

#### E6.4 Moisture content

The moisture content of straw bales should be determined before placing commences to ensure they are less than 20% equilibrium moisture content (EMC).

Bales with moisture content of 20% or above, or that show any signs of discoloration from exposure to moisture, mould, or fungus, should not be used in a straw-bale wall.

The moisture content of bales at the time of application of the first coat of plaster or the installation of another finish should not exceed 18% EMC.

Bales with moisture content greater than 18% and less than or equal to 20% EMC should be allowed to dry and be rechecked before plastering.

A minimum sample size of ten bales, and not less than 5% of bales in a building, should be randomly selected and tested. The moisture content of bales should be checked when they are delivered, before installation, and immediately prior to the application of the first plaster coat.

#### CE6.4

*The moisture content of bales should be determined with a moisture meter designed for use with baled straw or hay, equipped with a probe of sufficient length to reach the centre of the bale.*

*Plastering adds moisture to the bale walls so the straw needs to be at or below 18% before plastering commences.*

*Many practitioners prefer to only lay bales with an EMC less than 18% to give a margin for some pick-up of extra atmospheric moisture that may occur during construction.*

**E6.5 Exterior cladding risk matrix**

The building envelope risk matrix, Table D.1, may be used to determine whether walls should be suitable for direct plaster cladding, or should need a rain-screen cladding over a cavity system or other weather protective measures.

The design of cavity battens over straw-bale walls that supports weather protective cladding is outside the scope of this standard.

**CE6.5**

*The biggest risk factor from external moisture that straw-bale walls encounter is that posed by wind-driven rain.*

*Determining what constitutes the amount of exposure to wind-driven rain that will give reliable durability for direct plastered bales or otherwise determining when a cavity may be required is not simple.*

*Plaster over straw-bale walls can absorb moisture and the walls need to be able to dry out before the integrity of the plaster or the straw bale is compromised. Therefore, assessing the risk from wind-driven rain that a wall is exposed to is an important design consideration.*

*The risk matrix is one tool that may be used to help determine whether a cavity is required or not. It is weighted towards the conservative and its main application will be in areas of the country, and especially on exposed sites, that are subject to high annual rainfall and/or to frequent episodes of wind-driven rain.*

*Additional reduction risk factors are given to the score after an assessment is made of a range of factors specific to any site: sheltering features such as the effects of local geographic or landscaping features on any particular aspect of a building and exposure to wind-driven rain.*

*Assessment of the known direction of wind-driven rain particular to that site and the direction of severe storms on each aspect of the building, the annual rainfall data, and its localised directions can be made and risk adjusted accordingly.*

*If a particular site is known to only receive very minor amounts of rain, if any, from a particular direction, then the risk from wind-driven rain is reduced and overall risk factors may be reduced accordingly.*

*Other factors considered are relative and absolute humidity levels, and the drying potential from localised air movement.*

*Drying ability of the air outside of straw bales is influenced by exposure to drying winds and absolute humidity and this also varies from area to area and site to site, and some allowance has been made for this. The lower the annual absolute humidity (as opposed to relative humidity) the drier the air and the greater the drying potential.*

*The risk matrix may not be appropriate to use as a definitive method of determining whether a cavity is required or not in all areas where more detailed site-specific information may be available. There is a successful in-service history internationally of over 125 years and of over 25 years in New Zealand of direct-applied plasters, to straw-bale buildings in some areas of the country, and successful in-service history in similar locations may be a good source of comparative performance to help with the assessment.*

*Computer modelling, based on scientific research and using site-specific data, is progressing as another approach to help predict moisture levels within walls and the appropriate cladding systems, and to help determine whether a cavity system is required or not.*

*Any cladding system, either direct plastered or over a cavity, will require good detailing to ensure that the straw bales remain dry at all times, that is, less than 20% EMC, despite any moisture from external or internal sources that reaches the walls.*

*All cavity battens should be designed to determine their size, type, fixings, and spacing, and to suit the cladding and its fixing in order to meet the requirements of that cladding and/or any manufacturers' installation instructions for their claddings. For fixing of claddings refer to E2/AS1.*

*One method of fixing cavity battens that support weather protective cladding is shown in Figure E.8.*

**E6.6 Rain protection**

The minimum eave or roof overhang should be a minimum of 600 mm over any exterior direct plastered straw-bale wall unless a drained, ventilated cavity is provided behind any other cladding in accordance with NZBC E2/AS1.



The risk factor score associated with rain wetting of exterior walls is assessed using Appendix E, Table E1 and the cladding appropriate for each exposure level is given by Table D1.

### CE6.6

*Table D.1 gives guidance as to when it is appropriate to consider the use of direct plaster as an exterior cladding, as opposed to requiring a cavity system over straw-bale walls to give adequate weather protection in order to comply with NZBC E2.*

### E6.7 Wall cladding types

The suitable wall cladding for each wall is to be determined from Table D.1 for each wall using the total of the scores for risk factors A to E. The risk factor is reduced by the risk reduction factor F score from Table D.1. A separate cladding may be selected for each wall, or the highest risk score may be used for all walls. If walls are assessed individually refer to 2.7.3 for the methodology for dealing with rain from different directions.

**Table E.1 – Suitable wall claddings for straw-bale walls in accordance with Table D.1**

| Risk score | Suitable cladding   |
|------------|---|
| 0–6        | Plaster directly applied to straw-bale walls  |
| 7–12       | Cladding over 20 mm minimum drained ventilated cavity, over 10 mm minimum, exterior plaster to all straw-bale walls.<br>Eaves over a ventilated drained cavity should be suitable for the cladding type in accordance with E2/AS1 |
| >12        | Specific design beyond scope of this appendix.  |

### CE6.7

*For a risk matrix score of 7 to 12, specific design may include all cladding types allowed by E2/AS1 for fastening over a drained cavity that is ventilated at the bottom and formed by vertical battens.*

*The battens should be securely fastened to the wall or structural framing at a maximum spacing suitable for the cladding and will require specific design when not directly fixed over a timber stud or structural member. See D6.6.5.*

*Where cladding requires fastening to horizontal battens then these need to be incorporated over vertical battens.*

*Exterior cladding including wood, metal, stucco plaster or other cladding over a cavity should be spaced a minimum of 20 mm from the wall's encapsulating plaster to allow for moisture diffusion.*

*Building underlay should not be placed between cavity battens and plastered straw bale.*

## E7 Plaster

### E7.1 General

The exterior face of straw-bale walls suitable for direct plastering as per E6.5 should be protected by a weather-resistant plaster in accordance with this section and NZS 4298 section 8.

Straw-bale walls should be fully encapsulated with water-vapour permeable plaster unless abutting other water-vapour permeable materials or structure.

A truth window that shows the unplastered straw behind sealed glass is permitted.

Plaster systems generally include mesh or reinforcing fibres to control cracking and micro-cracking.

**CE7.1**

*External plasters if direct applied to the straw-bale walls form the weather-resistant cladding.*

*It is important that plaster skins are crack free to exclude external water, but also limit exposure to air. If air can move freely in and out of bales it can carry moist air into the bales.*

*It is important that all bale surfaces are fully encapsulated with vapour permeable surfaces, that is, surfaces with a permeance more than to equal to 290 ng/Pa.s.m<sup>2</sup> (SI unit). See surface coatings NZS 4298, section 8.*

*Encapsulating the bales also helps protect the bales from fire and vermin.*

*The insulation values also rely on the bales being fully encapsulated.*

**E7.2 Preparation of straw-bale walls prior to plastering****E7.2.1 Voids**

All voids in straw-bale walls, and between bales and supporting structure, should be tightly filled before plastering.

Voids between full straw bales less than 200 mm in width should be tightly filled with intact flakes of straw as baling proceeds.

Voids greater than 200 mm should be tightly filled with custom-made bales as baling proceeds of equal density to the original bales. All other voids between bales or at bale junctures should be filled with tightly packed straw or straw-clay, before application of finish.

**E7.2.2 Finish**

All straw-bale walls should be left trimmed or otherwise left with a tidy surface suitable for plastering.

**E7.3 Plaster thickness****E7.3.1**

External plaster not protected by a drained cavity and other cladding, should be a minimum of 25 mm thick (all coats combined), and should be applied in not less than three coats. Plaster should be applied so that no crack penetrates all three layers.

Internal exposed walls should have a minimum plaster thickness of 20 mm all coats combined.

All other straw-bale wall surfaces such as the tops of walls in ceiling spaces, or behind cavities (E7.3.3), or otherwise hidden but open to the air either internally or externally, should either receive a coat of fibrous plaster no less than 10 mm thick, or greater where required elsewhere in this appendix, to fully encapsulate the straw or abut vapour permeable structure or other material.

The permeance of any plaster coatings is altered by the thickness of the coating, and this may influence the thickness of any plaster coating specified. (Permeance is halved when thickness is doubled.) See NZS 4298, clause C8.11.

**CE7.3.1**

*Internal and external plaster may vary in thickness up to 50 mm to fill irregularities in the substrate.*

*Alternatives to plaster such as unpainted timber plywood or magnesium oxide board may need to be considered in areas where it is often difficult to undertake plastering or difficult to inspect, so as to establish water vapour permeable protection in these areas. Wall tops in particular may need this treatment.*

**E7.3.2**

In climate zone 3, straw-bale wall surfaces should receive a coat of plaster no less than 10 mm thick anywhere straw would otherwise touch metal or other non-permeable surface or be separated by 20 mm minimum thick timber or solid insulation. This applies to elements such as bracing elements and steel posts.

**E7.3.3**

Exterior plaster to straw-bale walls protected by a ventilated and drained cavity and other cladding should be not less than 10 mm thick. These thin plasters do not require any reinforcing mesh apart from embodied fibres to prevent cracking as specified in NZS 4298 clause 8.10.4.

Ensure that there are no air gaps from plaster shrinkage between these plasters and any embedded timbers.

**E7.4 Earth plaster**

Earth plaster for interior walls should comply with this appendix and NZS 4298 clause 8.7 where applicable.

**CE7.4**

*Earth plasters applied to exterior straw-bale walls, either as straightening coats, base coats, or finishing coats are outside the scope of this standard.*

**E7.5 Lime plaster**

Lime plaster, fibres, and mesh should comply with this appendix and NZS 4298 clause 8.10 where applicable.

Lime plaster may be applied internally or externally.

**CE7.5**

*Lime plaster applied over earth plaster is outside the scope of this standard. See NZS 4298 clause C8.10.2.6.*

*Lime plaster may be applied over hessian that has been used as a mesh and applied using clay slip over timber members and flashings.*

*The straw substrate should be sprayed with lime water immediately before direct plastering with lime plaster.*

**E7.6 Lime-cement plaster**

Lime-cement based plaster and mesh should comply with this appendix and NZS 4298 clause 8.10.3 where applicable. See also NZS 4298 clauses 8.10.2.3 and C8.10.3.

Untreated or timber treated to H3 or less should be separated from cement-lime plaster by a DPC or bituminous building underlay.

**E7.7 Cement plaster**

Cement plaster with less than one part lime to five parts cement should not be applied directly to any straw-bale walls (NZS 4298 clause C8.10.3).

**CE7.7**

*Cement plasters in accordance with NZS 4251 may be used as a cladding over a ventilated drained cavity.*

**E7.8 Gypsum plaster**

Gypsum plaster should comply with this appendix and NZS 4298 clause 8.9 where applicable, and be used on internal walls only, or used as a finishing coat over other internal plaster that complies with this appendix and NZS 4298 section 8.

**E7.9 Plaster finishes**

For plaster finishes and maintenance see NZS 4298 clause 8.11.

**E7.10 Plaster reinforcement – mesh and reinforcing fibres**

Well-compressed straw-bale walls are a suitable substrate for plasters.

Plaster systems should include mesh or reinforcing fibres to control cracking and micro-cracking and as required by NZS 4298 section 8 and as modified here.

**CE7.10**

*The surface of a well-constructed and compressed straw-bale wall functions as lath, and no other lath or mesh should be required except as required for in-plane or out-of-plane resistance as required by SED, and at corners to walls or at corners of openings where the risk of cracking or of damage is higher. Mesh may be installed where timber structure and bales join for both in-plane and out-of-plane resistance subject to SED.*

*If reinforced plaster skins are regarded as part of a composite panel with a straw-bale core, then they will need to be engineered as such.*

**E7.11 Mesh to joints between straw bale with other materials**

Mesh may include loose weave hessian or jute, polypropylene mesh in accordance with NZS 4298 clause 8.10.6, fibreglass mesh in accordance with NZS 4298 clause 8.10.7, or other plasterers' mesh such as galvanised steel mesh in accordance with NZS 4298 clause 8.10.8, or a range of fibres in accordance with NZS 4298 clause C8.10.4.

Where bales abut other materials, plaster reinforced with mesh complying with NZS 4298 section 8 should be used to bridge the joints and to prevent cracking with all types of plaster.

Mesh should be embedded in the first coat of plaster during plaster application and should extend a minimum of 200 mm onto the face of the bales.

Mesh may be attached to straw bales with galvanised high-tensile steel fencing wire U-pins with two 130 mm minimum legs, or by polypropylene twine tied through the bales and stapled to adjacent structure as necessary to secure the mesh in place before plastering.

Mesh attached to adjoining timber should be attached with fastenings and spacers as per NZS 4298 clauses C8.10.5 and 8.10.1.3 and 8.10.11.

**CE7.11**

*When plastering over the joint between straw and timber, straw and metal, or straw and sheet material, the non-straw substrate should be first covered by a slip layer of vapour-permeable building underlay. The building underlay should not extend over the bales. The slip layer is to prevent hang-up and the mesh is to prevent cracking with all types of plaster. For example, between straw and timber, straw and metal, and straw and sheet material. Unless the timber, metal, or sheet material is very rough the bond is not good enough to cause hang-up. The purpose of the mesh is to prevent cracking due to differential movement so the mesh should not be mechanically fixed to the timber structure except at edges of plaster panels when spacers are required between mesh and timber or other material.*

*E2/AS1, section 9.3, item 9.3.3.3 plus Figures 74, 75, and 76.*

*Applications of fibrous lime plaster through mesh can be dangerous because of the caustic nature of the lime and the risk of splashing if nailing or stapling mesh is carried out through a layer of wet plaster.*

*If plaster is well keyed into bales and mesh is well embedded in plaster then U-pins or twine may not be required to help place the mesh over the body of the wall.*

**E8 Separation of bales from other materials, materials, and membranes****E8.1 Water-resistive or non-permeable sheet**

Plastered bale walls should not be constructed with any building underlay or membrane barrier between straw and plaster, apart from minor areas such as window flashings.

Sheet bracing or panels, apart from vapour permeable (unpainted) sheet material or magnesium oxide board, should not be used abutting exterior straw-bale wall surfaces. Plywood should have a maximum thickness of 9 mm.

Sheet bracing or panels may be used abutting interior straw-bale wall surfaces if the straw is tightly fitted against vapour permeable sheet material or wall panel with a permeance greater than 290 SI units.

Water vapour permeability is to be determined in accordance with ASTM E96 / E96M – 16.

**CE8.1**

*This is to facilitate transpiration of moisture from the bale surfaces, and to prevent any membrane trapping moisture in the walls, and to secure a structural bond between straw and plaster.*

*Sheet bracing or linings may act as a membrane and interfere with moisture control.*

**E8.2 Separation of bales and concrete**

Bales should not be laid up to, or against, a concrete or concrete masonry or fired-brick masonry retaining or exterior wall.

Bales should be separated from concrete and masonry in any other situation with timber or rigid insulation member no less than 20 mm thick and a DPM applied to the adjoining brick or concrete surfaces.

**CE8.2**

*This requirement is to separate bale walls from poorly insulated or cold surfaces that might be a source of moisture or promote condensation of any water vapour passing through the bales.*

*Any air gap should either be drained and ventilated, and the hidden bale surface covered with 10 mm minimum earth or lime plaster, or the gap may be filled with an insulating material such as wood or rigid insulation with a permeance greater than 300 SI units.*

**E8.3 Steel connectors and strapping**

Steel pins, rods, or dowels should not be used in direct contact with straw in straw-bale walls in NZS 4218 climate zone 3.

Metal strap cross bracing on exterior walls should have a minimum of 10 mm of earthen or lime plaster applied between the straw and metal strap, with mesh (that is hessian or similar as a slip layer) in the earthen or lime plaster over the metal strap.

**CE8.3**

*There is a small risk of moisture condensing on steel surfaces in colder regions. Wrapping metal cross bracing with hessian and plastering helps mitigate this risk, as does placing steel cross bracing on the interior surface of external walls. See also CE5.1*

**E8.4 Separation of bales and structural steel members**

Structural steel members should be separated from bales by a timber or rigid insulation member 20 mm minimum thick.

**E9 Interior wet areas and penetrations in external walls****E9.1 Splash zones in interior wet areas**

Bales in walls enclosing showers or in other splash zones should be protected by a cavity or timber-framed wall that is waterproofed and provided with splashbacks or lined in accordance with clause E3 of the NZBC.

**E9.2 Penetrations in exterior walls**

All penetrations should be sealed against air infiltration on the interior side of the wall.

Any exposed straw that is otherwise hidden from view such as in ceiling spaces or behind electrical flush boxes should be plaster encapsulated.

**CE9.2**

*Penetrations in exterior walls, excluding doors and windows, should be located as high as possible to give maximum weather protection from roof overhangs.*

*Face-mounted external joinery is the safest in terms of excluding external moisture. Windows recessed back into the walls require carefully detailed flashings at heads, sills, and jambs that drain moisture to the exterior of the exterior plaster. However, recessed windows provide better insulation around the perimeter of the joinery. Designers need to carefully consider and balance these factors.*

**E9.3 Flashings to windows, doors and other exterior penetrations**

Flashings to all exterior openings should be designed and installed so that any water that might reach them is intercepted and directed to the exterior of the plaster system.

A drip edge on recessed openings or a head flashing should be installed at all openings.

Windowsills should have a full width sill flashing that should be of corrosion resistant metal or plastic that should have rear and side upstands and installed so that any water is directed beyond the outer face of plaster below.

Windowsill or sub sills should project water at least 40 mm clear of the face of the exterior plaster face below them.

If there is a window sub sill above the flashing in tile, brick, timber, or other material, the sub-sill should form a drip 40 mm minimum clear of the finished exterior plaster face and the flashing should direct water to the exterior face of the plaster. If there is no sub-sill covering the outer edge of the sill flashing, then the sill flashing itself should extend to drip a minimum 40 mm clear of the exterior plaster face.

Where the windowsill or sub-sill is not mortared to the sill flashing, a minimum gap above the flashing of 6 mm is to be provided to prevent capillary wicking of water (refer: E2/AS1 Figure 127 for sill flashing junction with side upstands). See Figures E.2 and E.5.

Jamb flashings should be of durable metal or plastic (uPVC). They are to be dressed down into and onto the sill flashing, over the upstands.

**CE9.3**

*Detailing of flashings around penetrations and of the junctions between joinery and straw bales requires detailed care.*

*Face mounting is easiest to install to give good weathering but recessed joinery gives better insulation around the joinery perimeter.*

*Joinery that is face mounted with flanges extending over the exterior plaster on the exterior face of straw-bale walls is easier to design and provide adequate sill and jamb flashings, but harder to design and provide adequate head flashings.*

*It is easier to design adequate head flashings for recessed joinery, but harder to design sill flashings.*

*Joinery that is recessed gives better thermal performance around the edges of the opening but the flashings require careful attention.*

*Recessed joinery requires recessed head, jamb and sill flashings so that any water is directed to the exterior of the plaster system.*

*Windows with deep exterior timber reveals can have recessed jambs and be finished with facings and flashed as if face mounted (see Table D.1 note (7)).*

*A sub-sill is an additional brick or a timber sill provided below the main window sill to give the required projection of the window sill out beyond the face of external plaster. Generally a timber sill trimmer is part of the assembly, see Figure E.2.*

*See also CTable D.1 for comments on the effect of window placement on thermal performance.*

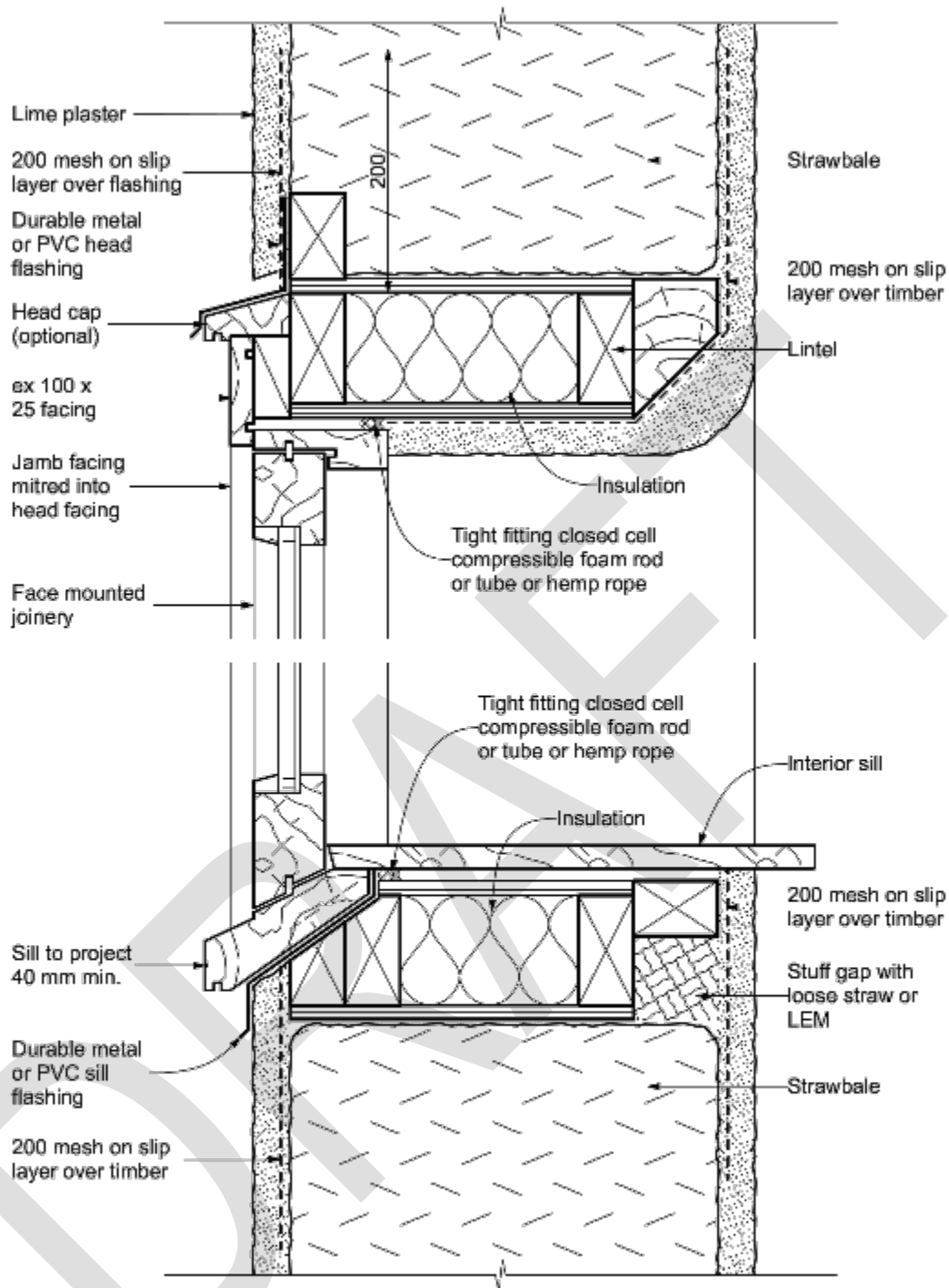

**NOTE-**  
 Head flashing to have 15° fall, 35 min. upstand behind plaster and 10 cover to head cap. Extend flashing and head cap 20 min. beyond outer edge of facing boards and form stop ends. Sill flashing to have 20 stop-ends and 35 min. cover to plaster.

**Figure E.2 – Head and sill for sheltered walls direct plastered**

## E10 Roof

Roofs should be designed in accordance with NZS 3604 if applicable or to SED.

### CE10

*Many designers prefer to devise a methodology of building that puts a finished roof on the building before bales are placed into the walls to give additional weather protection to unplastered straw bales.*

*Support of the roof, bond beams, top plates, and adequate connection and restraint of the top of the straw bales are outside the scope of this standard.*

*Roof design needs to be carefully considered so that any future failure that may lead to moisture getting into straw-bale walls is avoided or mitigated.*

*Gutters and downpipes are required on all straw-bale buildings and should be fitted before bale stacking if the roof is in place. Where the roof is installed after the bale stacking, the bales require temporary weather protection to ensure that the bales remain dry, and gutters and downpipes should be installed immediately after the roof is installed.*

*Some practitioners put a DPC layer on top of the wall to protect against potential future roof leaks.*

## E11 Pipework and straw-bale walls

Plumbing and drainage pipes should be run directly through straw-bale walls in a sleeve that drains to the exterior. Where feasible, plumbing and drainage pipes should not be placed within straw-bale walls.

Plumbing and drainage pipes on the face of straw-bale walls should be separated from the plaster.

### CE11

*Pipework within straw-bale walls should be minimised as there is the risk of leaking but also water pipes can be cool and act as a point of moisture condensation within the walls.*

*Exterior pipework through a straw-bale wall requires careful detailing that should include pipe insulation and a sleeve with downward slope to the exterior face of outside of the wall.*

## E12 Electrical services in straw-bale walls

Any penetrations through plaster skins need to be well sealed, and items such as flush boxes should be plastered behind them to limit air infiltration.

### CE12

*It is recommended that all electrical wires be run within conduits within bales or otherwise behind skirtings and scotias to allow for future maintenance.*

## E13 Thermal insulation R-value

The insulation value of a plastered straw-bale wall with bales laid flat can be taken as R 0.25 °C.m<sup>2</sup>/W per 25 mm thickness plus the R-value of the plaster skins plus surface effects.

The insulation value of a straw-bale wall with bales on edge can be taken as R 0.35 °C.m<sup>2</sup>/W per 25 mm thickness plus the R-value of the plaster skins plus surface effects.

The *k* value for earth and lime plasters may be taken as 0.7 W/m°C giving an R-value of 0.02 when

$R(\text{Surface effects}) = R 0.9 \text{ (internal) C.m}^2/\text{W} + R 0.3 \text{ (external) C.m}^2/\text{W}$  and may be taken as together as equal to R 0.12 C.m<sup>2</sup>/W.



**CE13**

*The difference in R-values between bales on flat and bales on edge is due to the orientation of the straws within the bales. Effectively this means that a bale on edge has very near the same R-value as a bale on the flat.*

*A 450 mm bale on the flat would have at least  $R = 4.5$  (straw) +  $0.12$  (lime plaster) +  $0.12$  (surface effects) =  $4.7$   $C.m^2/W$ .*

*A 350 mm bale on edge would have at least  $R = 4.9$  (straw) +  $0.12$  (plaster) +  $0.12$  (surface effects) =  $5.1$   $C.m^2/W$ .*

**Recommended minimum R-values**

*Because straw-bale walls provide a high insulation level, it is strongly recommended that all the other components chosen also have greater than minimum insulation levels.*

**E14 Durability**

Straw-bale walls meet the requirements of NZBC B2 for minimum durability if the weather protection, moisture, and surface coating requirements, of this appendix are met, and normal maintenance is carried out (NZS 4229, clause 8.11).

A 50-year minimum durability may be achieved for straw-bale walls. See NZBC B2.

**E15 Fire****E15.1 Fire risk during construction**

Straw-bale walls are vulnerable to fire until they are plastered.

**CE15.1**

*Loose straw is a particular fire hazard during construction.*

*Risk can be reduced by measures that include:*

- (a) Cleaning up any loose straw daily and removing it from the building site.*
- (b) No smoking on site.*
- (c) Provision of fire extinguishers on site.*
- (d) Use caution when using petrol motored trimmers or chain saws. Only electric powered line grass trimmers are recommended within 10 m of bales or loose straw.*
- (e) Angle grinders or other equipment that may emit sparks require caution when used within 10 m of bales or straw.*
- (f) Welding on site is to be undertaken with caution and ideally completed prior to installing bales into walls.*
- (g) Site fencing to exclude all unauthorised persons.*
- (h) Provision for firefighting water.*

**E15.2 Clearance to fireplaces and chimneys**

Straw-bale surfaces adjacent to fireplaces or chimneys should be finished with a minimum 25 mm thick reinforced plaster of any type permitted by this appendix and should have no cracks.

**CE15.2**

*Clearance from the face of such plaster to fireplaces, flues, and chimneys should be maintained as required from fireplaces and chimneys to combustibles in AS/NZS 2918 or as required by manufacturer's installation instructions, whichever is more restrictive.*

*Refer to B1/AS3 for small chimneys and C/AS1 section 7.5 for the installation of masonry or concrete chimneys.*

*Installation of horizontal flues from solid fuel heaters or boilers installed passing through an external LEM wall is outside the scope of this standard. See also E11.*

**E15.3 Fire-resistance**

Straw-bale walls should be considered to be non-rated for fire.

**CE15.3**

*Lime and earth plastered straw bales have survived Australian bush fires, and other fires, very well and some tests of plastered straw-bale walls in the USA, Australia and Germany have given good results. However, there is a lack of testing that complies with the latest testing criteria.*

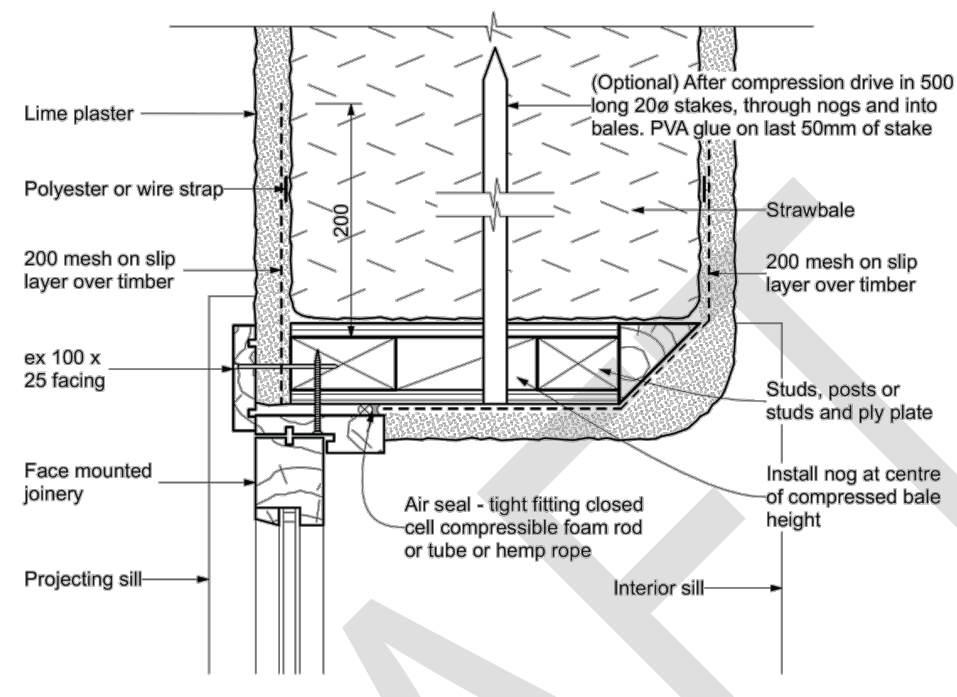

**Figure E.3 – Jamb for sheltered walls direct plastered**

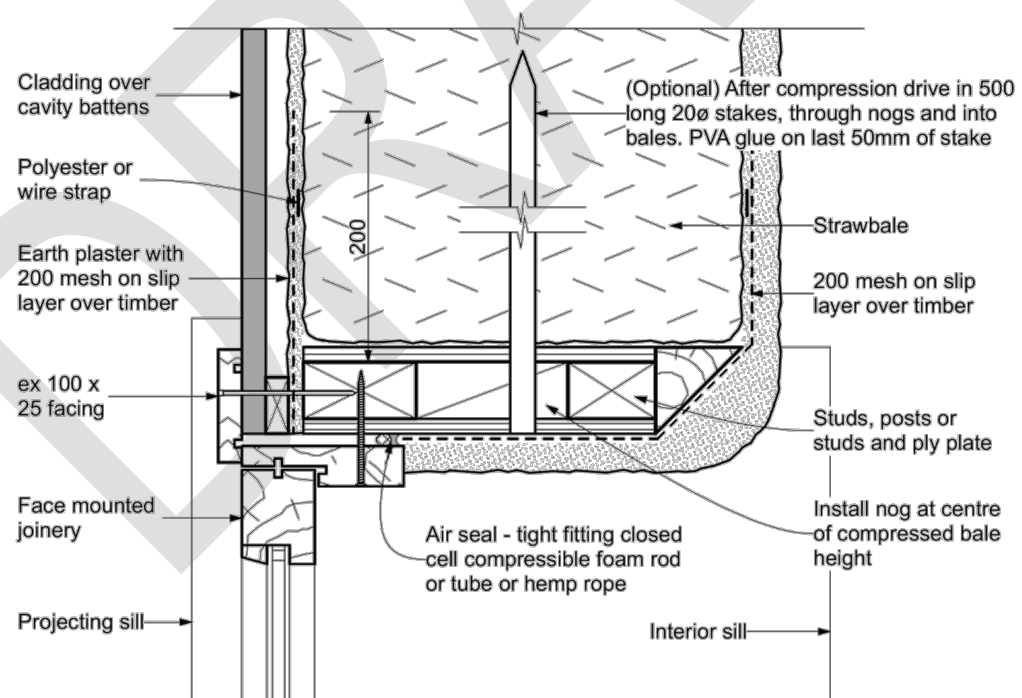

**Figure E.4 – Jamb for drained vented cavity walls**

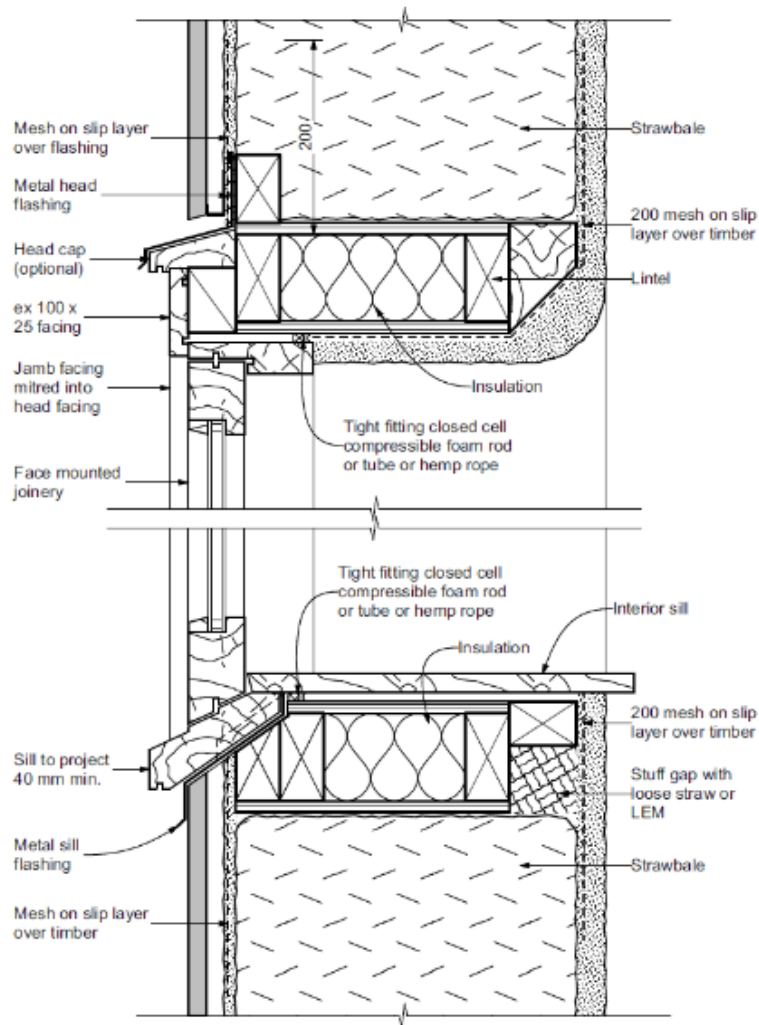

NOTE-  
 Metal head flashing to have 15° fall, 35 min. upstand behind cladding and 10 cover to head cap. Extend flashing and head cap 20 min. beyond outer edge of facing boards and form stop ends. Metal sill flashing to have 20 stop-ends and 35 min. cover to plaster.

Figure E.5 – Head and sill for drained vented cavity walls

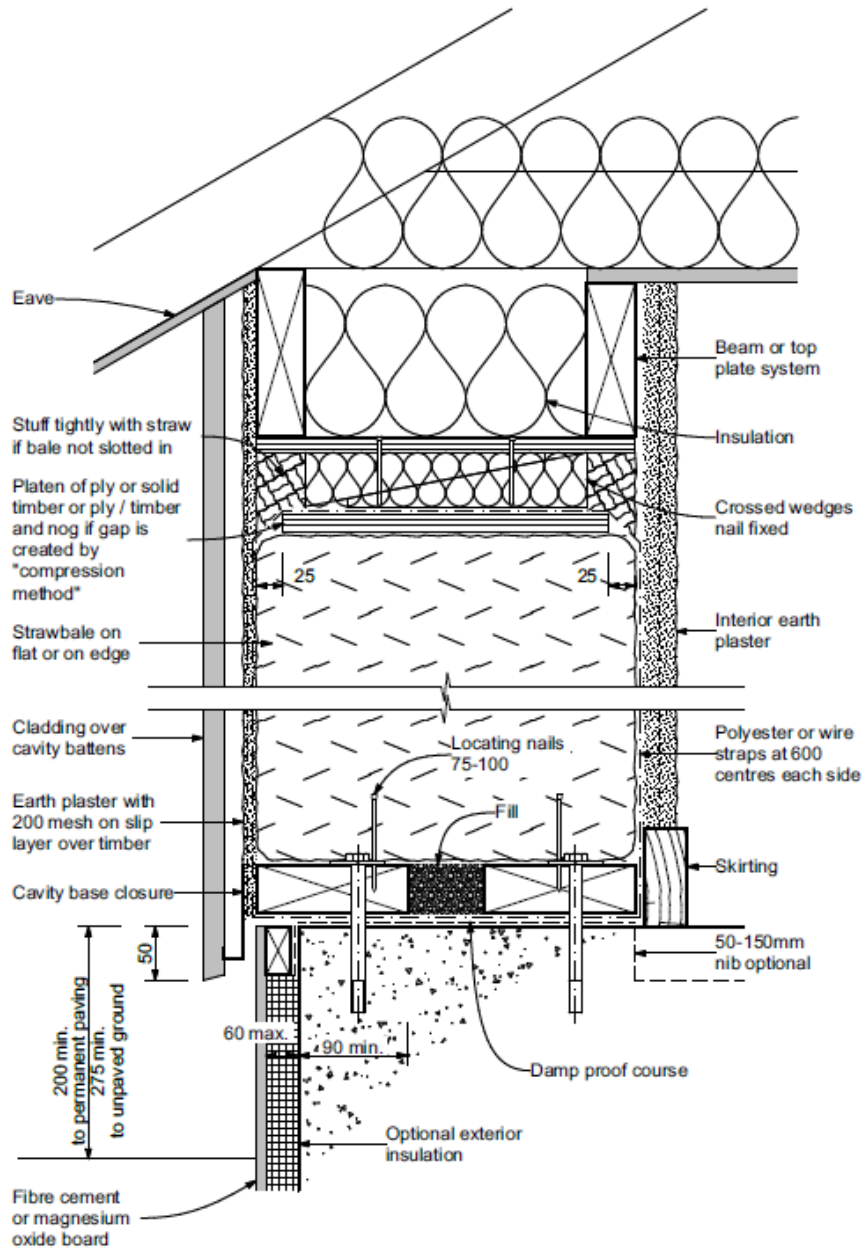

Figure E.6 – Straw-bale wall with drained vented cavity

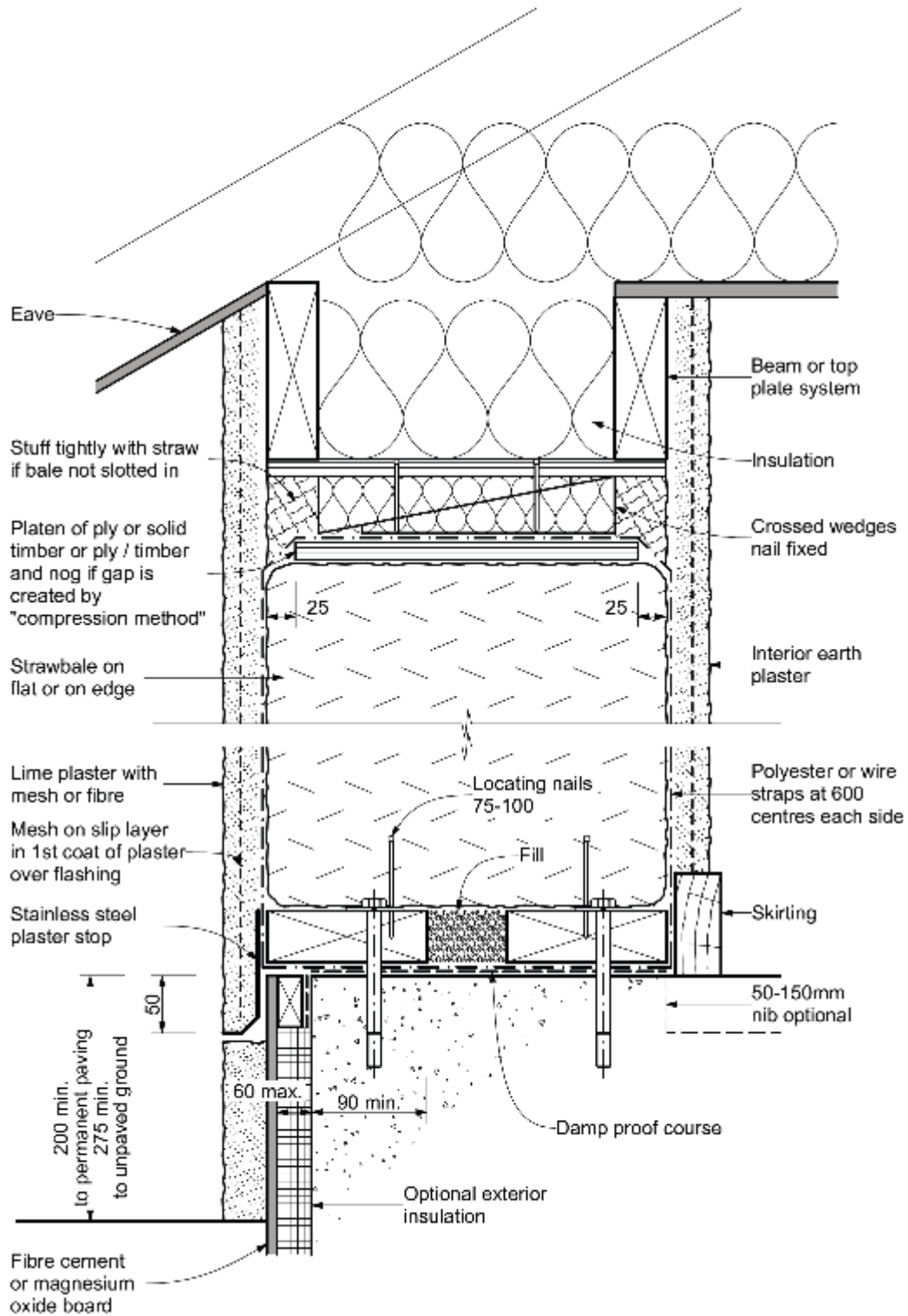

Figure E.7 Straw-bale wall with direct plaster

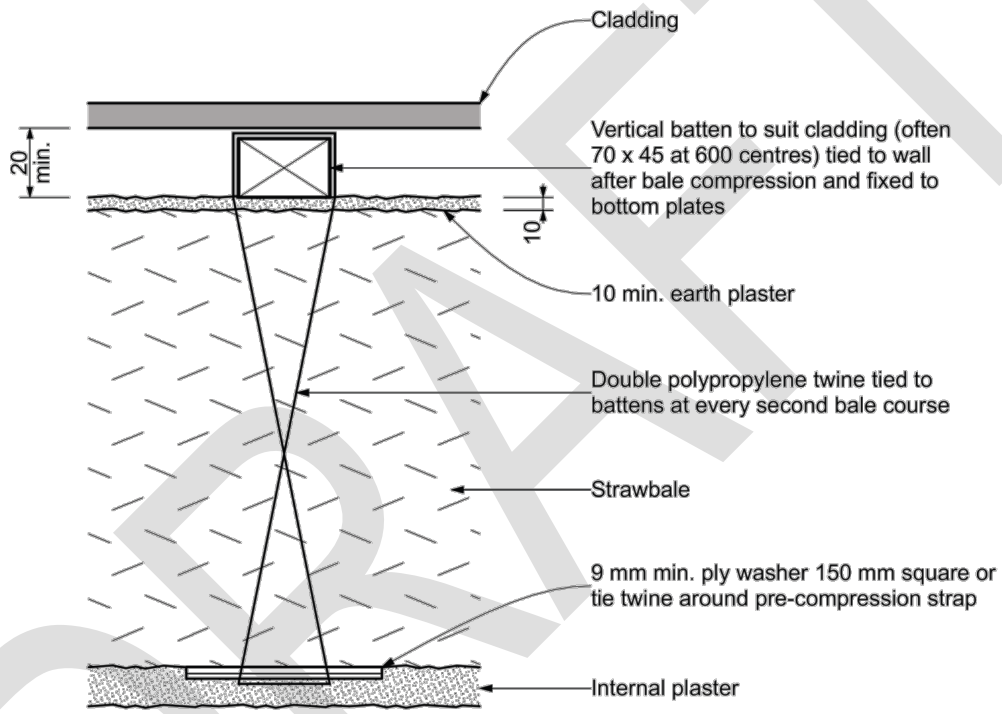

Figure E.8 – Batten tied to straw bale

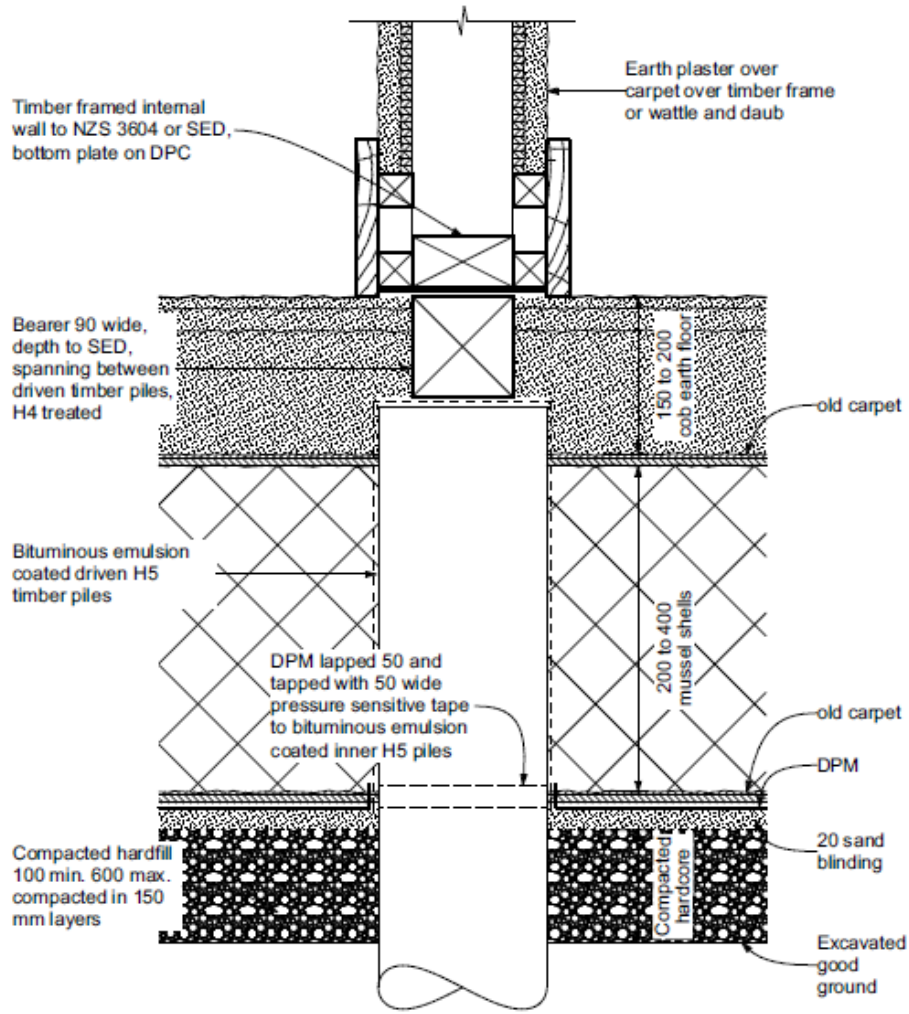

Figure E.9 – Internal wall on driven timber piles to SED

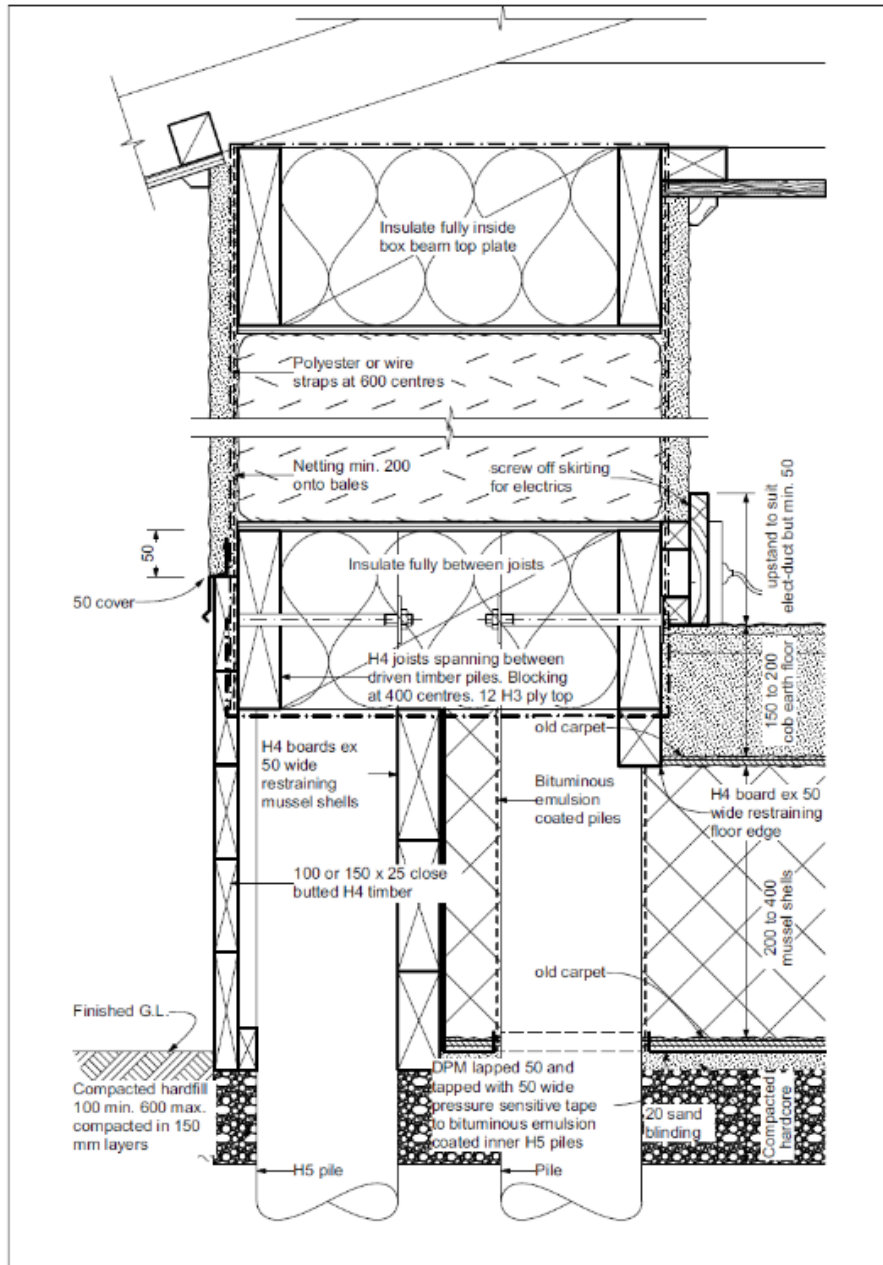

Figure E.10 – External wall on driven timber piles to SED



## APPENDIX F – INTERNAL ADOBE BRICK VENEER

### (NORMATIVE)

#### F1 Scope

##### F1.1

Internal adobe brick veneer described in this section applies to buildings constructed to NZS 3604 with modifications and limitations specified in this section.

Adobe internal brick veneer (see Figure F.1) shall have:

- (a) A maximum height  $h$ , from the top of the timber bottom plate to the top of the timber top plate :
  - (i) For the 90 mm x 45 mm studs supporting the adobe brick veneer of 3.0 m in earthquake zone 1, 2.6 m in earthquake zone 2, and 2.2 m in earthquake zone 3, or
  - (ii) For the 140 mm x 45 mm studs supporting the adobe brick veneer of 3.6 m in earthquake zones 1 and 2, and 3.2 m in earthquake zone 3;
- (b) A maximum mass of adobe veneer including applied plaster of 300 kg per square metre of wall face;
- (c) Light wall cladding only with a mass not exceeding 30 kg per square metre on the other side of the stud from the adobe veneer. Typical examples are timber weatherboards, plywood or plasterboard;
- (d) Studs with sizes, spacing, and maximum height,  $h$ , from the top of the bottom plate to the top of the top plate as specified in Table F.1 and Table F.2;
- (e) Internal adobe brick veneer walls do not contribute to the bracing of the building, but their mass shall be taken into account when calculating the bracing demand of the building;
- (f) The additional bracing demand for the adobe veneer walls, as calculated in accordance with F.14, shall be added to the bracing demand calculated for the building as determined in accordance with section 5 – Bracing Design of NZS 3604;
- (g) Pressed earth veneer brick shall be to SED;
- (h) Cement stabilised earth brick veneer shall be to SED.

Exterior adobe veneers and adobe veneers other than those on the ground floor are outside the scope of this standard.

#### F2 Foundation

##### F2.1

Adobe brick veneer shall be supported by one or a combination of the following:

- (a) Reinforced concrete foundation;
- (b) Thickened slab edge footing;
- (c) Internal reinforced concrete slab thickening.

##### F2.2

Footing details shall be in accordance with Figure F.1, other than those for concrete raft slabs, which shall be in accordance with Figure F.2, and shall be the total width of the timber framing plus the cavity (if any) plus the width of the adobe internal veneer wall, but with a minimum of 240 mm. The footings shall have a minimum depth of 400 mm. The footings shall be reinforced with one D12 bar at the top and two D12 bars at the bottom, and R10 ties at 600 mm centres for earthquake zone 1, and R10 ties at 400 mm centres for earthquake zones 2 and 3.

##### F2.3

Footings for concrete raft slabs shall be as per Figure F.2, having the total width of the timber framing plus the cavity (if any) plus the width of the internal veneer wall, and shall be a minimum of 300 mm wide. The footings shall have a minimum depth of 300 mm. The footings shall be on firm original ground with ultimate bearing

capacity of not less than 300 kPa. The footings shall be reinforced with two HD12 bars at the top and bottom and R10 ties at 600 mm centres for earthquake zone 1-, and 400-mm centres for earthquake zones 2 and 3.

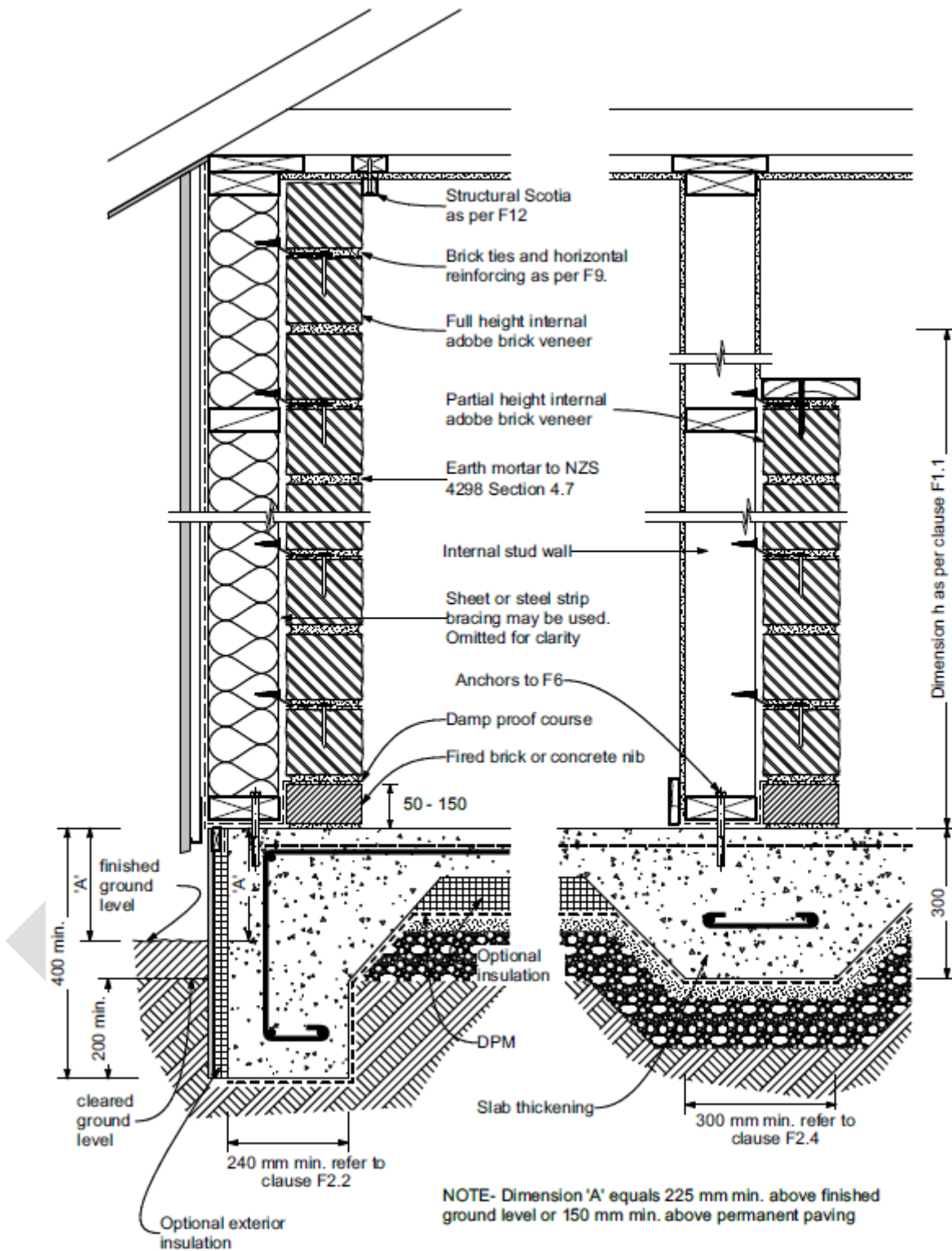

Figure F.1 – Internal veneer details

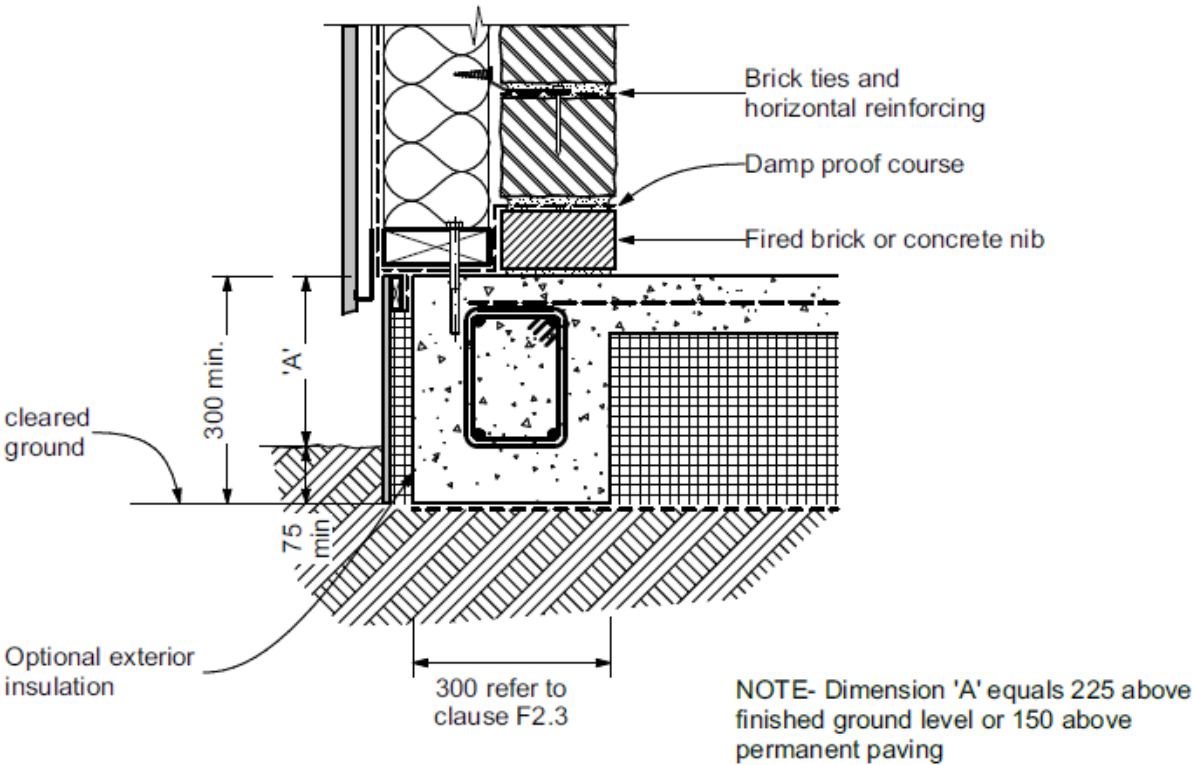
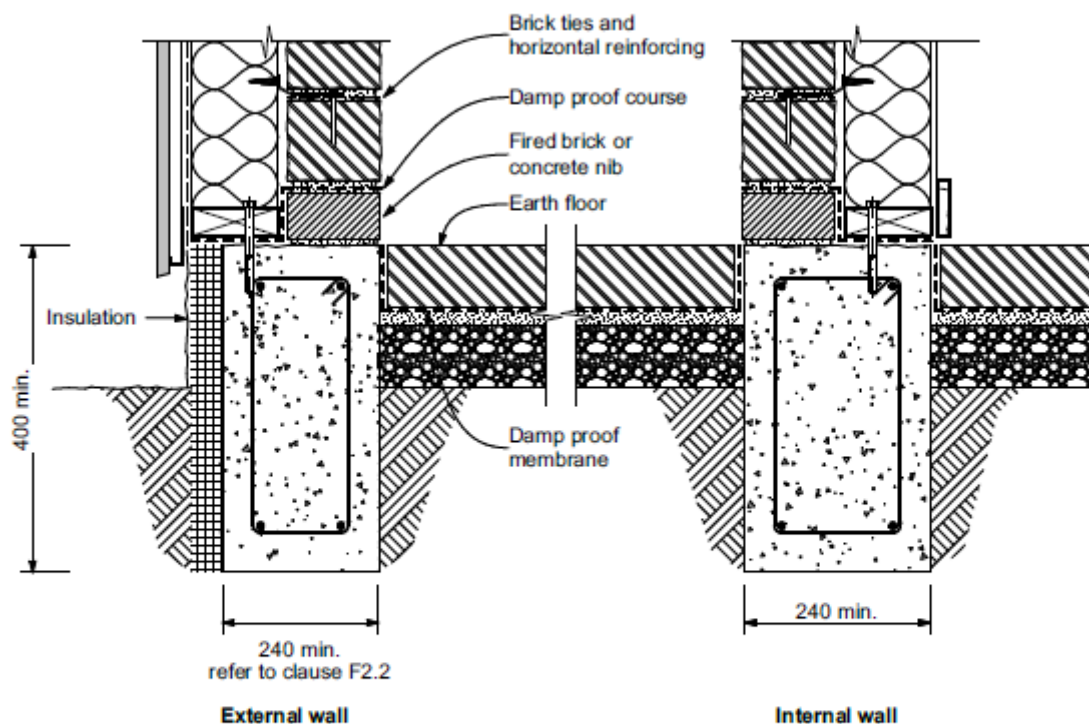

Figure F.2 – Footing – Internal adobe veneer, concrete raft foundation

DRAFT



## NOTES

1. Dimensions to finished ground level and to cleared ground level and height of nib to be as per Figure F.1.
2. Cover to reinforcing to be as per Figure 5.3.

**Figure F.3 - Internal adobe veneer with earth floor**

**F2.4**

Footings for internal walls shall be the total width of the timber framing plus the cavity (if any) plus the width of the internal veneer wall, but with a minimum of 300 mm. The footings shall have a minimum depth of 300 mm. The footings shall be into firm original ground with ultimate bearing capacity of not less than 300 kPa. The footings shall be reinforced with 2/D12 or 2/HD12 with 75 mm bottom cover and R10 ties at 600 mm centres for earthquake zone 1, and R10 ties at 400 mm centres for earthquake zones 2 and 3.

**F2.5**

Footings for internal adobe veneer with earth floor shall be as per Figure F.3, having the total width of the timber framing plus the cavity, if any, plus the width of the internal adobe veneer wall, and shall be a minimum of 240 mm wide. The footings shall have a minimum depth of 400 mm. The footings shall be reinforced with two D12 bars at the top and two D12 at the bottom and R10 ties at 600 mm centres for earthquake zone 1, and at 400 mm centres for earthquake zones 2 and 3.

**F3 Upstand****F3.1**

The height from the interior finished floor level to the underside of the bottom course of adobe veneer bricks on interior walls shall be a minimum of 50 mm.

**F3.2**

The concrete or fired brick upstand shall be the width of the internal veneer wall. Roughen the top of the upstand to provide a key for the earth mortar or **the first course of bricks shall be laid in a 1:3 lime: sand mortar.**

**F3.3**

Fired bricks shall be in accordance with AS/NZS 4455 with mortar composed of Portland cement or lime, sand, and water with an admixture in accordance with the provisions of NZS 4210, clause 2.2.

**F4 Damp-proof course**

The top of the upstand shall be provided with a damp-proof course in accordance with 5.6.5.

**F5 Timber Framing****F5.1**

The timber studs supporting the adobe veneer walls shall be as per Table F.1 for adobe veneer walls with mass including plaster of less than or equal to 220 kg/m<sup>2</sup> and as per Table F.2 for adobe veneer walls with mass including plaster of less than or equal to 300 kg/m<sup>2</sup>. The height of the studs, *h*, in Table F.1 and Table F.2 shall be measured from the top of the timber bottom plate to the top of the timber top plate.

**Table F.1 – Studs for adobe veneer walls less than or equal to 220 kg/m<sup>2</sup> including plaster**

| Stud size and spacing (mm)     | Maximum height of adobe veneer wall<br>(m) |      |      |
|--------------------------------|--|------|------|
|                                | Earthquake zone                            |      |      |
|                                | 1  | 2    | 3    |
| 90 × 45 SG8 at 600 mm centres  | 2.60                                       | 2.30 | 1.90 |
| 90 × 45 SG8 at 400 mm centres  | 3.00                                       | 2.60 | 2.20 |
| 90 × 90 SG8 at 600 mm centres  | 3.30                                       | 2.90 | 2.40 |
| 90 × 90 SG8 at 400 mm centres  | 3.60                                       | 3.20 | 2.80 |
| 140 × 45 SG8 at 600 mm centres | 3.60                                       | 3.30 | 3.00 |
| 140 × 45 SG8 at 400 mm centres | 3.60                                       | 3.60 | 3.20 |

**Table F.2 – Studs for adobe veneer walls less than or equal to 300 kg/m<sup>2</sup> including plaster**

| Stud size and spacing (mm)      | Maximum height ( <i>h</i> ) of studs for adobe veneer wall<br>(m) |      |      |
|---------------------------------|---|------|------|
|                                 | Earthquake zone   |      |      |
|                                 | 1   | 2    | 3    |
| 90 × 45 SG 8 at 600 mm centres  | 2.40  | 2.10 | 1.80 |
| 90 × 45 SG 8 at 400 mm centres  | 2.70  | 2.40 | 2.00 |
| 90 × 90 SG 8 at 600 mm centres  | 3.00  | 2.60 | 2.20 |
| 90 × 90 SG 8 at 400 mm centres  | 3.40  | 3.00 | 2.50 |
| 140 × 45 SG 8 at 600 mm centres | 3.50  | 3.20 | 2.80 |
| 140 × 45 SG 8 at 400 mm centres | 3.60  | 3.60 | 3.20 |

NOTE: – SED is required for heights of adobe veneer walls greater than 3.6 m in earthquake zones 1 and 2, and greater than 3.2 m in zone 3.

**F5.2**

The studs in external walls, particularly in very high and high wind zones, shall comply with the requirements of NZS 3604, section 8, Table 8.2, if the studs in the NZS 3604 Table 8.2 are larger or at closer spacings than shown in the Tables F.1 and F.2 above.

**F5.3**

The timber bottom plate and the timber top plate shall be the same width as the stud and have a minimum thickness of 45 mm.

**F5.4**

The top plates of loadbearing walls shall also comply with all the requirements of NZS 3604 section 8, particularly Table 8.16, and be strengthened with a double top plate as required by NZS 3604 Table 8.16, particularly for trusses or rafters at a spacing greater than 900 mm. A double top plate shall be provided at gable end walls unless there is a floor diaphragm complying with NZS 3604 section 7.4 or a ceiling diaphragm complying with NZS 3604 section 13.5.

**F5.5**

Connections for joints in top plates and at intersections of top plates shall be as per NZS 3604 section 8.

**F5.6**

The studs shall be fixed to the timber bottom plate and timber top plate in earthquake zone 1 with Type A fixing with either three 100 mm long by 3.75 mm diameter nails or four 90 mm long by 3.15 mm diameter nails or two 100 mm long 10-gauge screws through the plate and into the stud or be fixed with an alternative fixing with a capacity not less than 2 kN. The studs shall be fixed to the timber bottom plate and timber top plate in earthquake zones 2 and 3 with Type B fixing with two 100 mm long 14 gauge screws through the plate and into the stud or be fixed with an alternative fixing with a capacity not less than 4 kN.

**CF5.6**

*Concealed metal purlin cleats, 1.55 mm thick x 40 mm wide galvanised steel and with two Type 17 mm 14 gauge x 35 mm long screws each leg giving a capacity of greater than 2 kN together with two 90 mm x 3.15 mm diameter nails through the top plate into the stud could be used for Type A fixing.*

*Concealed metal purlin cleats, 1.55 mm thick by 80 mm wide galvanised steel and with four Type 17 by 14 gauge by 35 mm long screws each leg giving a capacity of greater than 4 kN together with two 90 mm x 3.15 mm diameter nails through the top plate into the stud could be used for Type B fixing.*

**F5.7**

Dwangs between the studs shall be spaced at not more than 1350 mm centre to centre and shall be not less than 90 x 45 mm and fixed to the stud each end with two 90 mm by 3.15 mm nails, skewed or end nailed.

**F6 Timber bottom plates****F6.1 Fixing bottom plates**

Bottom plates of adobe veneer walls shall be fixed to reinforced concrete floors either by cast-in anchors in accordance with F6.2 or by proprietary post fixed anchors in accordance with F6.3. The durability of all anchors shall be in accordance with NZS 3604 for 'all zones', 'all other structural fixings' in a 'closed' environment.

Anchors providing end fixings of bracing elements shall comply with all the requirements of F6.1 as well as their function of resisting bracing element uplift.

**F6.2 Cast-in anchors**

Cast-in anchors shall be M12 bolts set within 150 mm of each end of the plate, spaced at a maximum of 1200 mm centres, bent to prevent turning and projecting sufficiently to allow a washer and fully threaded nut above the timber. Where the slab edge is formed with in-situ concrete, anchors shall be set not less than 90 mm into the concrete, maintaining a minimum edge distance of 50 mm:

- (a) For internal and external walls, where the slab edge is formed with in-situ concrete, anchors shall be set not less than 90 mm into the concrete, maintaining a minimum edge distance of 50 mm;
- (b) For external walls where the slab edge is formed with masonry header blocks, anchors shall be set not less than 120 mm into the concrete, maintaining a minimum edge distance of 50 mm to the outside face of the blocks.

Cast-in proprietary anchors of equivalent strength and durability to the cast-in anchor detailed in (a) and (b) above may be used.

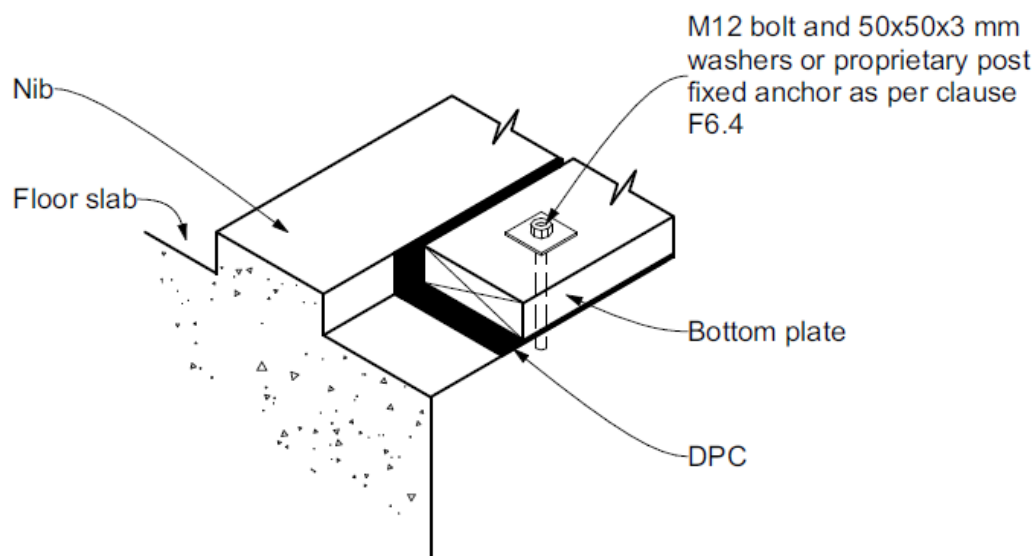

**Figure F.4 – Fixing of bottom plates to slabs and cast-in anchors**

### **F6.3 Proprietary post fixed anchors**

Proprietary anchors shall be within 150 mm of each end of the plate and be spaced at a maximum of 900 mm centres, or 600 mm centres when used on slab edges formed by masonry header blocks.

### **F6.4**

For all adobe veneer walls, proprietary anchors shall have a minimum capacity when tested in accordance with NZS 3604 section 2 as follows:

- (a) Horizontal loads in the plane of the wall – 2 kN;
- (b) Horizontal loads out of the plane of the wall – 3 kN;
- (c) Vertical loads in axial tension of the fastener – 7 kN.

## **F7 Cavities**

### **F7.1**

A cavity up to 40 mm wide can be provided between the adobe brick veneer and the interior face of the timber framing but is not required.

### **F12.7.2**

Pipes and services may be placed in the cavity.

## **F8 Adobe veneer bricks**

### **F8.1**

Adobe veneer bricks shall have a minimum width of 120 mm and a maximum height of 150 mm.

### **F8.2**

Adobe brick veneer shall have a maximum thickness so that mass of adobe veneer including applied plaster does not exceed 300 kg per square metre of wall face.

**F8.3**

Adobe veneer bricks shall comply with the requirements of NZS 4298 for adobe bricks for compression or flexural tensile strength as per Table 2.1 of NZS 4298. The adobe veneer bricks do not need to pass the wet/dry appraisal, erosion, or drip tests of Appendices J, K and L respectively of NZS 4298.

**F8.4**

The adobe bricks shall be laid using earth-based mortar complying with NZS 4298, clause 2.4.

**F8.5**

Adobe veneer bricks shall be laid in accordance with NZS 4298 including the tolerances of Table 2.2 of NZS 4298.

**F8.6**

Adobe veneer bricks shall be laid in stretcher bond, with vertical mortar joints aligned on alternate courses.

**F8.7**

Mortar joints shall be completely filled without gaps.

**F8.8**

The maximum number of courses of adobe brick veneer to be laid in one day shall be four or no more than 60 mm total mortar course heights per day, with the brick courses below allowed to dry at least overnight before the geogrid layer and ties are installed in the uppermost layer constructed during the day.

**F9 Wall ties****F9.1**

Adobe veneer bricks shall be attached to the studs with hot dip galvanised steel wall ties, which shall be fixed to the timber studs at the same spacing as the studs, 400 mm to 600 mm centres horizontally, and maximum 300 mm centres vertically and also within 200 mm of openings and at the last course at the top of the wall.

**F9.2**

The wall ties shall be fixed to the timber studs with hot dip galvanised 14 gauge or 12 gauge screws a minimum of 35 mm into the studs. Where rigid underlay has been used, the length of the fixing screw shall be increased by the thickness of the underlay so that the screw penetrates a minimum of 35 mm into the stud.

**F9.3**

Wall ties shall be placed over the top of any horizontal reinforcing and fixed to bricks with a minimum of one 90 mm long x 3.15 mm diameter galvanised nail or 65 mm long x 10 gauge galvanised screw installed vertically through the horizontal reinforcing and into the top of the brick.

**F9.4**

Wall ties shall be of such a length that they have an embedment length of at least half the width of the adobe veneer brick.

**F10 Horizontal reinforcing****F10.1**

Polypropylene biaxial geogrid with a minimum ultimate tensile strength greater or equal to 30 kN/m, or triaxial geogrid mesh with a radial secant stiffness at 0.5% strain of 390 kN/m, shall be installed in the mortar courses at 300 mm centres vertically, and in the same course as the wall ties.



**F10.2**

The geogrid mesh shall be installed so that it is contained within the mortar bed, with a layer of mortar both above and below the mesh.

**F10.3**

The geogrid mesh shall be minimum of 100 mm wide for adobe veneer walls up to 200 mm wide. For wider adobe veneer walls the geogrid mesh shall be the width of the wall minus 40 mm each side, with 20 mm clearance from the finished face of the bricks.

**F11 Openings****F11.1**

Openings with adobe brick veneer above shall be spanned by timber lintels 150 mm deep for a maximum span of 1.5 m, and minimum 200 mm deep for a maximum span of 1.8 m and the full thickness of the adobe veneer wall. The height of adobe veneer wall above the lintel shall be equal to or less than 600 mm. Lintels for openings greater than 1.8 m or lintels with adobe veneer greater than 600 mm above the lintel shall be to SED.

**F11.2**

Lintels shall be fixed to the timber studs with a minimum of two hot dip galvanised steel wall ties at each stud fixed as per F9 above.

**F11.3**

The timber lintels shall have a minimum seating of 300 mm on the adobe veneer bricks at each end.

**F11.4**

Lintels shall only be installed once the supporting adobe brick veneer below the lintels has had time to settle, which shall be a minimum of 7 days from the end of laying bricks to the level of the lintel support.

**F12 Securing top bricks**

A scotia board, minimum 40 mm × 20 mm, shall be fixed as shown in Figure F.1. The scotia shall be secured to the ceiling framing with at least one 2.8 mm nail or one 8 gauge screw at 300 mm maximum spacing.

**CF12**

*The scotia's function is to secure the top course of bricks that are not directly secured by a brick tie to ensure safety when subject to seismic shaking.*

**F13 Wall finishing**

Refer to NZS 4298, section 8.

**CF13**

*It is recommended to keep the earthen surface completely water vapour permeable.*

**F14 Wall bracing design****F14.1**

The wall bracing design for the timber-framed building enclosing the adobe veneer walls, including the wall bracing elements, spacing of bracing lines, and minimum bracing line values and bracing capacity shall be in accordance with NZS 3604 section 5.

**CF14.1**

*Adobe veneer does not provide bracing capacity. If bracing is needed in a wall with adobe veneer, shear bracing either or both sides of the wall may be provided in accordance with NZS 3604 or SED.*

The earthquake bracing demand for the building shall be increased as calculated below in F.15.

**F15 Additional wall bracing demand for adobe veneer walls**

**F15.1**

The additional wall bracing demand (AWBD) for the adobe veneer walls shall be calculated by multiplying the total face area of adobe veneer wall above mid-height of the wall from the foundation to the bond beam ( $A_v$ ) by the thickness of adobe veneer wall ( $T_v$ ) by the density of the adobe veneer wall ( $\rho_v$ ) by the site earthquake factor ( $K_e$ ) in Table F.3 and as per Equation F-1 below.

$$AWBD = A_v \times T_v \times \rho_v \times K_e \times 0.2 \text{ bracing units (BUs)} \dots\dots\dots (\text{Eq. F-1})$$

**Table F.3 – Site earthquake factor for calculation of additional wall bracing demand for adobe veneer walls**

| Soil Class           | Site earthquake factor, $K_e$ |      |      |
|----------------------|-------------------------------|------|------|
|                      | Earthquake zone               |      |      |
|                      | 1                             | 2    | 3    |
| Soil Classes A and B | 0.30                          | 0.45 | 0.69 |
| Soil Class C         | 0.37                          | 0.56 | 0.86 |
| Soil Classes D and E | 0.47                          | 0.71 | 1.09 |

**F15.2**

The density of the bricks for the adobe veneer wall ( $\rho_v$ ) shall be determined in accordance with Appendix M of NZS 4298.

**F16 Additional requirements for wall bracing for adobe veneer walls**

**F16.1 Adobe veneer walls greater than 2 m in length**

There shall be a wall bracing line at right angles to the adobe veneer wall within 2 m of each end of the adobe veneer wall with a minimum bracing capacity greater than 25% of the additional wall bracing demand (AWBD) of the individual adobe veneer wall unless a diaphragm complying with section 5.6 of NZS 3604 is provided.

**F16.2 Adobe veneer walls less than or equal to 2 m in length**

There shall be a wall bracing line at right angles to the adobe veneer wall within 2 m of one end of the adobe veneer wall with a minimum bracing capacity greater than 50% of the additional wall bracing demand (AWBD) of the individual adobe veneer wall unless a diaphragm complying with section 5.6 of NZS 3604 is provided.

**F17 Joints in top plates**

Joints in top plates for a timber-framed building with adobe veneer walls shall be in accordance with NZS 3604 clause 8.7.3.

**CF17**

*The requirements of NZS 3604 for connections at top plate level for walls containing bracing elements need to be taken into account.*

## APPENDIX G MAINTENANCE SCHEDULE FOR EARTH WALLS

(Normative)

### G1 Six-monthly inspection

Check gutters and drain and scupper outlets and remove leaves and obstructions as required.

### G2 Yearly and before winter, and after an earthquake

#### G2.1

Inspect the earth walls and the perimeter of window and door openings. If there are any gaps or holes of 3 mm to 15 mm wide, fill with mortar that matches the original earth building material. If gaps or holes are larger than 15 mm, or if you are not able to fill in the gaps, contact a contractor experienced in earth building to inspect and repair as required.

#### CG2.1

See C2.6.2.7 for repair of different wall materials

#### G2.2

Check clearances of the bottom of the earth wall from the present finished ground level. Re-establish correct clearances as required by Figure 5.2.

### G3 Every five years for earth walls

#### G3.1

Brush any loose material off from the earth wall with a soft brush, inspect the earth wall and inspect and do repairs as for Item G2.1 above.

### G4 Every ten years for walls with lime plaster

#### G4.1

Brush any loose material off from the lime plaster with a soft brush.

#### G4.2

Inspect the surface of the lime plaster. If there are any cracks in the plaster more than 2 mm wide contact an experienced lime plasterer to inspect the lime plaster and repair as required.

#### G4.3

Apply two coats of silicate paint or lime wash, or as instructed by the lime plasterer after he has made any repairs as required. If the lime plaster and previous coat of silicate paint or lime wash is in good condition the two coats of lime wash or silicate paint may be postponed for a further five years.

### G5 Records

Keep a written record with dates and details of:

- (a) All surface treatments.
- (b) All maintenance inspections.
- (c) All repairs required and completed.
- (d) Application of the coats of silicate paint or lime wash to lime plaster.

NOTE – Earthquake inspections: Inspections post-earthquake would be appropriate if the earthquake causes windows to crack, plaster to flake, or objects to slide or overturn in the house. (Not for just felt movement or only rattling dishes and swinging lampshades.)